

BENSHI HYDRAULIC GROUP

www.benshigroup.com



HYDRO-TEC

One of Benshi group companies

Our company establish since 1995 specialized in producing hydraulic fittings made from German mineral.

Our principle is (We not alone and not the best, But We work to be that)

We attempt from beginning to concern accuracy and high quality because its our aim.

- We match with the most new development in the world by imported newest programmed lathes (CNC) that arrived accuracy and speed simultaneously.
- Depend on competent engineers in industrial drawing, operating, and maintenance of newest machines.
- Select competent workmen in this field.

To working one hand to shake your hands.

We worked to cover the local requirements then We go to Arabic countries and go distance that.

Our exploration from quality and kinds with international standards.

We have ability to make special and specific pieces (shape - dimensions) witch can't produce by common lathes.

Because your complacency is our purpose:

- study prices by tidy way to be suitable to our and be you pleasure
- keep the pieces by sheathing their (plastic - toil) and caning in strong and befitting boxes.
- We stipulation with chipping company

If there any question or holler don't hesitate to contact us

مجموعة بنشي للهيدروليك

تأسست شركة بنشي عام ١٩٨٧ كشركة متخصصة باستيراد وتوزيع خرطوم الهيدروليك ثم ما لبثت أن طورت نشاطها و أصبحت مجموعة بنشي للهيدروليك التي تتألف من الشركات التالية:

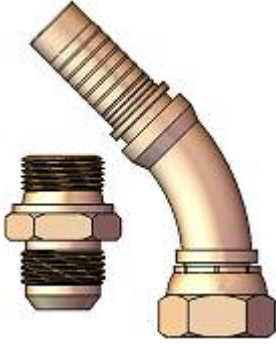

شركة متخصصة بإنتاج
رؤوس خرطوم
الهيدروليك والمكيف
جميع المقاسات والأنواع

HYDRO-TEC



شركة متخصصة باستيراد
وتوزيع خرطوم
الهيدروليك والمكيف

شركة بنشي



الوكيل العام لشركة
نقارات Officine
Cancellara Michele
الايطالية الأكثر شهرة في
العالم

OCM



الوكيل الحصري في
الدول العربية وجنوب
إفريقيا لشركة نقارات
Korean Hydraulic
Hammer
الكورية

KHH

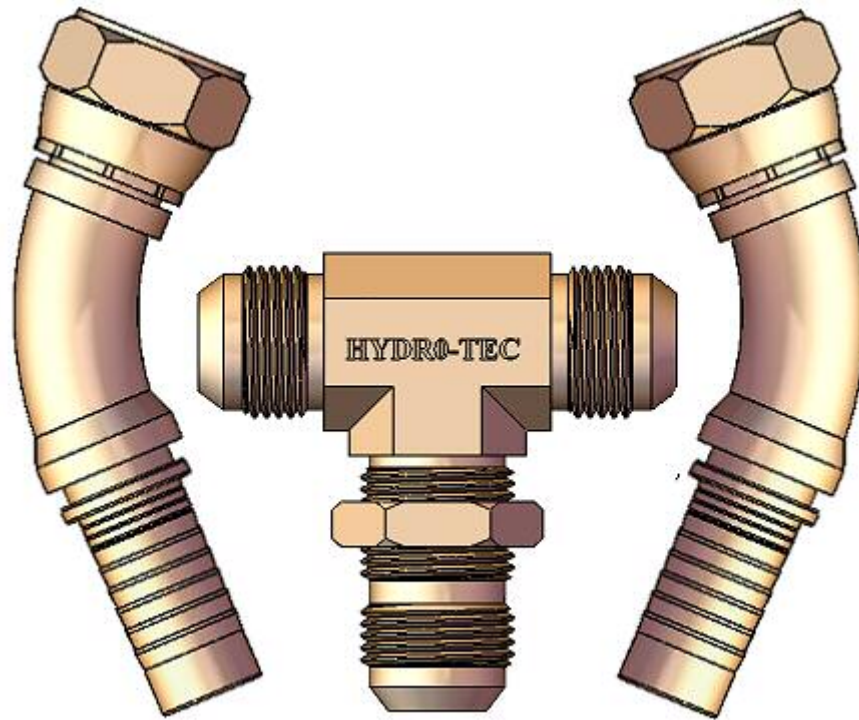

HYDRAULIC FITTINGS





FITTING INDEX

PAGE	PART REF.	STANDARD TYPE	النوع
007		FITTING NUMBERING SYSTEM	نظام ترقيم الرؤوس
009	HT00910	SWAGED FERRULE FOR SEA 100 R2 & R9R SKIVE	جلبة (سوكيت) مظفر طاقين + ٤ طاق قشط
009	HT03400	SWAGED FERRULE NON-SKIVE	جلبة (سوكيت) دون قشط
010	HT00110	SWAGED FERRULE FOR SEA 100 R1A DIN 20022 1ST HOSE SKIVE	جلبة (سوكيت) طاق واحد قشط
010	HT00800	SWAGED FERRULE FOR HOSE SIMILAR SEA 100 R7 & R8	جلبة (سوكيت) حرير
011	HT03100	SWAGED FERRULE FOR SEA 100 R1A DIN 20022 1ST HOSE NON-SKIVE	جلبة (سوكيت) طاق واحد دون قشط
011	HT03300	SWAGED FERRULE FOR SEA 100 R2A DIN 20022 2SN HOSE NON-SKIVE	جلبة (سوكيت) طاقين دون قشط
012	HT00200	SWAGED FERRULE FOR SEA 100 R2A + 2ST HOSE SKIVE + 4SP HOSE	جلبة (سوكيت) طاقين قشط
013	HT01000	SWAGED FERRULE FOR SEA 100 R10 & R9R DIN 20023 4SP HOSE	جلبة (سوكيت) ٤ طاق ضغط تخين (غليظ)
013	HT09900	SWAGED FERRULE FOR SEA 100 R12 & R9R DIN 20023 4SP HOSE	جلبة (سوكيت) ٤ طاق ضغط ثقيل
014	HT00900	SWAGED FERRULE FOR R9R DIN 20023 4SP HOSE	جلبة (سوكيت) ٤ طاق ضغط عالي
014	HT10710	BSPT MALE 60° CONE SEAT	ذكر سن إنكليزي BSPT + كونيك ٦٠°
015	HT10510	BSP MALE PARALLEL 60° CONE SEAT	ذكر سن إنكليزي مع مركز سيلة + كونيك ٦٠°
015	HT20511	BSP FEMALE 60 CONE SEAT	متحرك سن إنكليزي عرقة كبس
017	HT20591	90° BSP SWEPT ELBOW 60° CONE	كوع سن إنكليزي عرقة كبس
018	HT20541	45° BSP SWEPT ELBOW 60° CONE	نصف كوع سن إنكليزي عرقة كبس
019	HT10610	BSP MALE FLAT SEAT	ذكر سن إنكليزي وجه مسح
019	HT20611	BSP FEMALE FLAT SEAT	متحرك سن إنكليزي وجه مسطح
020	HT12810	NPTF MALE 60° CONE SEAT	ذكر سن NPTF كونيك ٦٠°
021	HT14110	NPTF SWIVEL MALL	ذكر متحرك NPTF
021	HT20881	90° BSP COMPACT ELBOW	كوع BSP طرق
022	HT12510	JIC MALE 74° CONE	ذكر سن أمريكي ٧٤°
023	HT22511	JIC FEMALE 74° CONE SEAT	متحرك سن أمريكي ٧٤° عرقة كبس
024	HT22591	90° JIC SWEPT ELBOW 74° CONE	كوع سن أمريكي ٧٤° عرقة كبس
025	HT22541	45° JIC SWEPT ELBOW 74° CONE	نصف كوع سن أمريكي ٧٤° كبس
026	HT22581	90° JIC COMPACT ELBOW	كوع JIC طرق
026	HT24791	90° JIC LONG SWEPT ELBOW 74° CONE	كوع سن أمريكي طويل ٧٤° عرقة كبس



HYDRO – TEC

PAGE	PART REF.	STANDARD TYPE	النوع
027	HT21313	METRIC MULTISEAL FEMALE	متحرك متري عام
027	HT21393	90° METRIC SWEPT ELBOW MULTISEAL	كوع متري عام
028	HT21343	45° METRIC SWEPT ELBOW MULTISEAL	نصف كوع متري عام
029	HT11510	METRIC MALE 24 CONE SEAT L.T.	ذكر متري ٢٤°
030	HT21513	O’RING METRIC FEMALE 24 CONE L.T.	متحرك متري ٢٤° بسيلة
031	HT21593	90° O’RING METRIC SWEPT ELBOW 24 CONE L.T.	كوع متري ٢٤° بسيلة
032	HT21543	90° O’RING METRIC SWEPT ELBOW 24° CONE L.T.	نصف كوع متري ٢٤° بسيلة
033	HT11610	O’RING METRIC FEMALE 24° CONE HEAVY DUTY (H.T)	ذكر متري ٢٤° أعمال ثقيلة
034	HT21613	O’RING METRIC FEMALE 24° CONE HEAVY DUTY (H.T)	متحرك متري ٢٤° أعمال ثقيلة
035	HT21693	90° O’RING METRIC SWEPT ELBOW 24° CONE H.T.	كوع متري ٢٤° أعمال ثقيلة
036	HT21643	45° O’RING METRIC SWEPT ELBOW 24° CONE H.T. 5	نصف كوع متري ٢٤° أعمال ثقيلة
036	HT24913	WASH CLEANER FEMALE (TYPE K)	أنثى مغسلة
037	HT12410	OFRS FEMALE	ذكر ORFS
038	HT22413	OFRS FEMALE	أنثى ORFS
039	HT22493	90° OFRS FEMALE	كوع ORFS
040	HT22443	45° OFRS FEMALE	نصف كوع ORFS
040	HT24111	ST JIS FLANGE (JAPANESE TYPE)	مستقيم فلنجة ياباني
040	HT24145	45° JIS FLANGE (JAPANESE TYPE)	نصف كوع فلنجة ياباني
041	HT24190	90° JIS FLANGE (JAPANESE TYPE)	كوع فلنجة ياباني
042	HT23311	STRAIGHT FLANGE 3000 P.S.I.	مستقيم فلانج قطعة واحدة ٣٠٠٠
042	HT23322	22.5° FLANGE 3000 P.S.I.	فلانج زاوية ٢٢.٥° قطعة واحدة ٣٠٠٠
043	HT23330	30° FLANGE 3000 P.S.I.	فلانج زاوية ٣٠° قطعة واحدة ٣٠٠٠
044	HT23345	45° FLANGE 3000 P.S.I.	نصف كوع فلانج قطعة واحدة ٣٠٠٠
044	HT23360	60° FLANGE 3000 P.S.I.	فلانج زاوية ٦٠° قطعة واحدة ٣٠٠٠
045	HT23367	67.5° FLANGE 3000 P.S.I.	فلانج زاوية ٦٧.٥° قطعة واحدة ٣٠٠٠
046	HT23390	90° FLANGE 3000 P.S.I.	كوع فلانج قطعة واحدة ٣٠٠٠
047	HT23390L	90° LONG DROP FLANGE 3000 P.S.I.	كوع فلانج ٩٠° طويل قطعة واحدة ٣٠٠٠
048	HT233110	110° FLANGE 3000 P.S.I.	فلانج زاوية ١١٠° قطعة واحدة ٣٠٠٠
048	HT233125	125° FLANGE 3000 P.S.I.	فلانج زاوية ١٢٥° قطعة واحدة ٣٠٠٠
049	HT233135	135° FLANGE 3000 P.S.I.	فلانج زاوية ١٣٥° قطعة واحدة ٣٠٠٠



HYDRO – TEC

PAGE	PART REF.	STANDARD TYPE	النوع
050	HT23611	STRAIGHT FLANGE 6000 P.S.I.	مستقيم فلانج قطعة واحدة ٦٠٠٠
051	HT23630	30 ° FLANGE 6000 P.S.I.	كوع فلانج ٣٠ ° قطعة واحدة ٦٠٠٠
051	HT23645	45 ° FLANGE 6000 P.S.I.	نصف كوع فلانج قطعة واحدة ٦٠٠٠
052	HT23645	60 ° FLANGE 6000 P.S.I.	كوع فلانج ٦٠ ° قطعة واحدة ٦٠٠٠
052	HT23690	90 ° FLANGE 6000 P.S.I.	كوع فلانج ٩٠ ° قطعة واحدة ٦٠٠٠
053	HT23690L	90 ° LONG DROP FLANGE 6000 P.S.I.	كوع فلانج ٩٠ ° طويل قطعة واحدة ٦٠٠٠
054	HT23711	LITTLE LONG DROP STRAIGHT FLANGE 6000 P.S.I.	مستقيم فلانج طويل قليلاً قطعة واحدة 6000 P.S.I.
054	HT23745	45 ° LITTLE LONG DROP STRAIGHT FLANGE 6000 P.S.I.	نصف كوع فلانج ٤٥ ° طويل قليلاً قطعة واحدة 6000 P.S.I.
054	HT23790	90 ° LITTLE LONG DROP STRAIGHT FLANGE 6000 P.S.I.	كوع فلانج ٩٠ ° طويل قليلاً قطعة واحدة 6000 P.S.I.
055	HT23911	STRAIGHT SAE FLANGE 9000 P.S.I.	مستقيم فلانج قطعة واحدة ٩٠٠٠
055	HT23922	22.5 ° FLANGE 9000 P.S.I.	كوع فلانج ٢٢.٥ ° قطعة واحدة ٩٠٠٠
056	HT23930	30 ° FLANGE 9000 P.S.I.	كوع فلانج ٣٠ ° قطعة واحدة ٩٠٠٠
056	HT23945	45 ° FLANGE 9000 P.S.I.	نصف كوع فلانج قطعة واحدة ٩٠٠٠
057	HT23960	60 ° FLANGE 9000 P.S.I.	كوع فلانج ٦٠ ° قطعة واحدة ٩٠٠٠
057	HT23967	67.5 ° FLANGE 9000 P.S.I.	كوع فلانج ٦٧.٥ ° قطعة واحدة ٩٠٠٠
058	HT23990L	90 ° LONG DROP FLANGE 9000 P.S.I.	كوع فلانج ٩٠ ° طويل قطعة واحدة ٩٠٠٠
059	HT23990	90 ° FLANGE 9000 P.S.I.	كوع فلانج ٩٠ ° قطعة واحدة ٩٠٠٠
059	HT83308	SPLIT FLANGE CLAMPS 3000 P.S.I.	قمرية فلانجة ٣٠٠٠
060	HT83608	SPLIT FLANGE CLAMPS 6000 P.S.I.	قمرية فلانجة ٦٠٠٠
060	HT14513	POCLAIN MALE FLANGE	ذكر فلانجة (طبشة) بوكلين
061	HT24513	POCLAIN FEMALE FLANGE	أنثى فلانجة (طبشة) بوكلين
061	HT24593	90 ° POCLAIN FEMALE FLANGE	كوع فلانجة (طبشة) بوكلين
062	HT22010	METRIC STANDPIPE STRAIGHT	مستقيم متري ذو رأس ماسورة
063	HT22090	90 ° METRIC STANDPIPE	كوع متري ذو رأس ماسورة
064	HT22040	45 ° METRIC STANDPIPE	نصف كوع متري ذو رأس ماسورة
065	HT23811	JAPANESE GAS JIS (TYPE T)	متحرك ياباني سن إنكليزي (تويوتا)
065	HT24011	JAPANESE METRIC FEMALE JIS (TYPE K)	متحرك ياباني سن متري (كوماتسو)
066	HT24091	90 ° JAPANESE METRIC JIS (TYPE K)	كوع ياباني سن متري (كوماتسو)
067	HT00IP00	WELDING TAIL	ذنب لحام
067	HT10050	HOSE CONNECTOR	وصلة خرطوم

نظام ترقيم أصناف الرؤوس FITTING PART NUMBERING SYSTEM

1 2 3 4 5

الرقم الأول FIRST DIGIT

FIRST DIGIT	DESCRIPTION	الوصف
0	SWAGED FERRULE	سوكيت (جلبة)
1	MULTIFIT TYPE MALE	ذكر من مختلف الأصناف
2	MULTIFIT TYPE FEMALE	متحرك من مختلف الأصناف
8	SPLIT FLANGE OR BOLT	قمرية فلانج أو برغي

1 2 3 4 5

الرقمين الثاني والثالث SECOND AND THIRD DIGIT

2 & 3 DIGIT	DESCRIPTION	الوصف
03	BSP BANGO	بانجو سن انكليزي
05	BSP THEARD (60 CONE)	سن انكليزي مركز سيلة
06	BSP THEARD (FLAT FACE)	سن انكليزي وجه مسح
07	BSPT THEARD	سن انكليزي BSPT
09	METRIC BANGO	بانجو متري
13	METRIC THEARD (MULTISEAL)	سن متري عام
15	METRIC FEMALE (24° CONE LIGHT)	سن متري خفيف
16	METRIC FEMALE (24° CONE HEAVY)	سن متري ثقيل
18	METRIC THEARD (FRENCH GAS)	سن متري موديل فرنسي
20	METRIC STAND PIPE	ماسورة متري
24	ORFS THEARD	سن ORFS
25	JIC THEARD (37° CONE)	سن أمريكي
28	NPTF THEARD	سن NPTF
33	FLANGE 3000	فلانج ٣٠٠٠
36	FLANGE 6000	فلانج ٦٠٠٠
39	FLANGE 9000	فلانج ٩٠٠٠
38	JAPANESE GAS JIS (TYPE T)	ياباني سن إنكليزي (تويوتا)
40	JIS (KOMATSU) THEARD	سن كوماتسو
41	NPTF SWIVEL MALE	ذکر متحرك سن NPTF
44	ORFS LONG ELBOW	كوع طويل ORFS
45	POCLAIN FLANGE	فلانج بوكلين
47	JIC LONG ELBOW	كوع طويل JIC

WHEN THE FIRST DIGIT IS 8

عندما يكون الرقم الأول ٨

2 & 3 DIGIT	DESCRIPTION	الوصف
33	SPLIT FLANGE 3000	قمرية فلانج ٣٠٠٠
36	SPLIT FLANGE 6000	قمرية فلانج ٦٠٠٠
02	BSP BOLT	برغي سن انكليزي
08	METRIC BOLT	برغي سن متري

HYDRO – TEC

① ② ③ ④ ⑤

FOURTH DIGIT الرقم الرابع

FOURTH DIGIT	DESCRIPTION	الوصف
1	STRAIGHT	مستقيم
2	22.5° SWEPT	٢٢.٥°
3	30° SWEPT	٣٠°
4	45° SWEPT	٤٥°
6	60° SWEPT	٦٠°
7	67.5° SWEPT	٦٧.٥°
8	COMPACT TYPE	نوع طرق
9	90° SWEPT	٩٠°

① ② ③ ④ ⑤

FIFTH DIGIT الرقم الخامس

FIFTH DIGIT	DESCRIPTION	الوصف
0	MALE OR FERRULE	ذكر أو سوكيت
1	CRIMPED-BACK NUT	عزق كبس
2	THRUST-WIRE NUT	عزق كوبيل
3	SPLIT-ON NUT	عزق دك

EXAMPLE

مثال

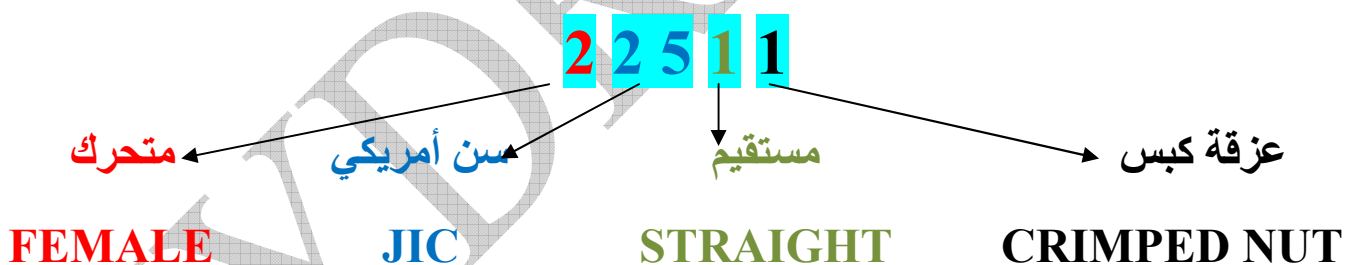

EXAMPLE

مثال

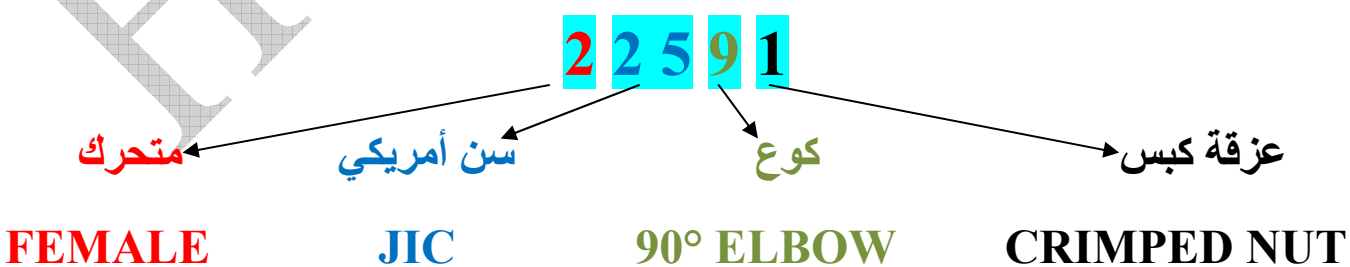

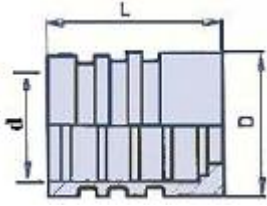

HT00910 SWAGED FERRULE FOR SAE 100 R2 AND R9R SKIVE

جلبة (سوکیت) مظفر طاқين + ء طاق قشط

رقم النموذج	السعر	العدد	فتحة الخرطوم		القياسات مم			ملاحظات
PART REF.	PRICE	QTY	HOSE BORE		DIMENSIONS mm			REM.
			DN	INCH	d	D	L	
HT00910 - 03			5	3/16"	12.8	20.6	26	
HT00910 - 04			6	1/4"	16	22	30	
HT00910 - 05			8	5/16"	16.3	24	31	
HT00910 - 06			10	3/8"	18.5	26	33	
HT00910 - 08			12	1/2"	22.75	30	34	
HT00910 - 10			16	5/8"	26	33	39	
HT00920 - 12			19	3/4"	29.75	38	40	
HT00920 - 16			25	1"	36.75	46	54	
HT00920 - 20			31	1. 1/4"	48.5	57	60	
HT00910 - 24			38	1. 1/2"	54.5	65	70	
HT00910 - 32			51	2"	68	79	72	

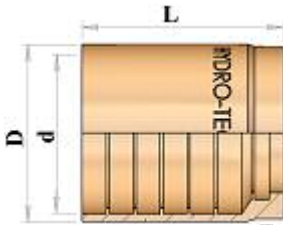

HT03400 SWAGED FERRULE NON- SKIVE

جلبة (سوکیت) دون قشط

رقم النموذج	السعر	العدد	فتحة الخرطوم		القياسات مم			ملاحظات
PART REF.	PRICE	QTY	HOSE BORE		DIMENSIONS mm			REM.
			DN	INCH	d	D	L	
HT03400 - 03			5	3/16"	15.3	21	23	
- 04			6	1/4"	15.5	23	30.5	
- 05			8	5/16"	18	24	30	
- 06			10	3/8"	20.8	26	32	
- 08			12	1/2"	23.25	29	34	
- 10			16	5/8"	26.25	33	37	
- 12			19	3/4"	31	37	42	
- 16			25	1"	39	46	51	
- 20			31	1. 1/4"	50	59	59	
- 24			38	1. 1/2"	56.5	67	67	
- 32			51	2"	69.5	80	72	

HYDRO – TEC

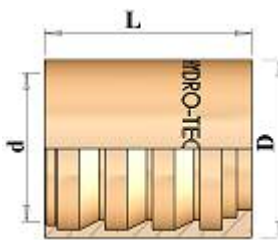

HT00110 SWAGED FERRULE FOR SAE 100 R1A DIN 2022 1ST HOSE SKIVE

جلبة (سوكيت) طاق واحد قشط

رقم النموذج	السعر	العدد	فتحة الخرطوم		القياسات مم			ملاحظات
PART REF.	PRICE	QTY	HOSE BORE		DIMENSIONS mm			REM.
			DN	INCH	d	D	L	
HT00110 - 03			4	3/16"	11.5	17.5	28	
- 04			6	1/4"	13.5	20	28	
- 05			8	5/16"	14.4	22	30	
- 06			10	3/8"	17.25	24	32	
- 08			12	1/2"	21.5	28	34	
- 10			16	5/8"	23.8	32	37	
- 12			20	3/4"	28.75	36	43	
- 16			25	1"	35.25	43	50	
- 20			32	1. 1/4"	42.4	50.8	59	
- 24			40	1. 1/2"	48	58	68	

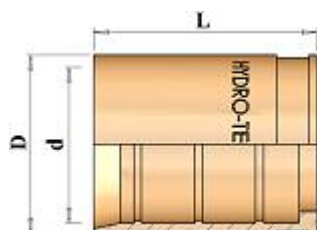

HT00820 SWAGED FERRULE FOR HOSE SIMILAR TO SAE 100 R7 AND R8

جلبة (سوكيت) حرير

رقم النموذج	السعر	العدد	فتحة الخرطوم		القياسات مم			ملاحظات
PART REF.	PRICE	QTY	HOSE BORE		DIMENSIONS mm			REM.
			DN	INCH	d	D	L	
HT00820 - 03			5	3/16"	11	14	26.4	
- 04			6	1/4"	13.75	18	30.2	
- 05			8	5/16"	15.2	19	32	
- 06			10	3/8"	17	22	33	
- 08			12	1/2"	21	26	34	
- 10			16	5/8"	24	30	36	
- 12			19	3/4"	27.75	33	42	
- 16			25	1"	34.7	41	50	
- 20			31	1 1/4"		48	57	
- 24			38	1 1/2"		55.5	66	
- 32			51	2"		68.6	70	

HYDRO - TEC

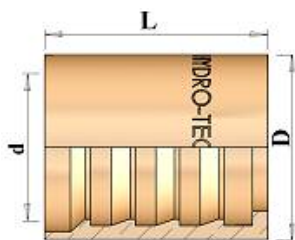

HT03100 SWAGED FERRULE FOR SAE 100 R1AT DIN 2002 1SN HOSE NON - SKIVE

جلبة (سوكيت) طاق واحد دون قشط + ٢ طاق قشط

رقم النموذج	السعر	العدد	فتحة الخرطوم		القياسات مم			ملاحظات
PART REF.	PRICE	QTY	HOSE BORE		DIMENSIONS mm			REM.
			DN	INCH	d	D	L	
HT03100 - 03			4	3/16"	12.5	17	27	
- 04			6	1/4"	13.5	19	28	
- 05			8	5/16"	16	21	28	
- 06			10	3/8"	18	23	31	
- 08			12	1/2"	21.5	27	34	
- 10			16	5/8"	24	32	38	
- 12			20	3/4"	28	35-36	45	
- 16			25	1"	36.75	43	50	
- 20			32	1. 1/4"	45	51/52	60	
- 24			40	1. 1/2"				
- 32			50	2"				

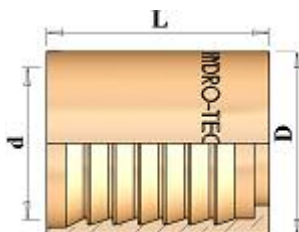

HT03300 SWAGED FERRULE FOR SAE 100 R2AT DIN 2002 2SN HOSE NON - SKIVE

جلبة (سوكيت) طاقين دون قشط

رقم النموذج	السعر	العدد	فتحة الخرطوم		القياسات مم			ملاحظات
PART REF.	PRICE	QTY	HOSE BORE		DIMENSIONS mm			REM.
			DN	INCH	d	D	L	
HT03300 - 04			6	1/4"	16	22	28	
- 05			8	5/16"	17.5	24	30	
- 06			10	3/8"	20	26	31	
- 08			12	1/2"	23	28	34	
- 10			16	5/8"	26.25	33.25	38	
- 12			20	3/4"	30.5	37	45	
- 16			25	1"	39.5	45/46	50	
- 20			32	1. 1/4"	49.25	56	60	
- 24			40	1. 1/2"	56	65	70	
- 32			50	2"				

HYDRO – TEC

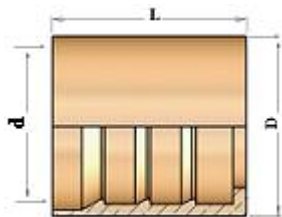

HT00200 SWAGED FERRULE FOR SAE 100 R2A +2ST HOSE SKIVE + 4SP HOSE
جلبة (سوكيت) طاقين قشط + ٤ طوق قصير

رقم النموذج	السعر	العدد	فتحة الخرطوم		القياسات مم			ملاحظات
PART REF.	PRICE	QTY	HOSE BORE		DIMENSIONS mm			REM.
			DN	INCH	d	D	L	
HT00200 - 04			6	1/4"	15	21	30	
- 05			8	5/16"	17	24	30	
- 06			10	3/8"	18	25	31.5	
- 08			12	1/2"	22	30	34	
- 10			16	5/8"	25.5	33	40	
- 12			20	3/4"	29.5	38	45	
- 16			25	1"	36.5	45/46	50	
- 20			32	1. 1/4"	45	56	60	
- 24			40	1. 1/2"	53	62	70	
-32			50	2"	65	75	70	

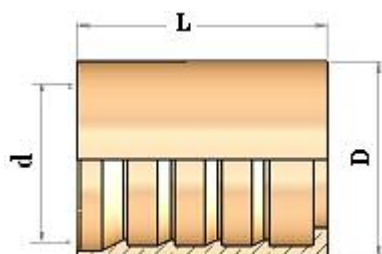

HT00200 SWAGED FERRULE FOR SAE 4SP HOSE
جلبة (سوكيت) ٤ طوق

رقم النموذج	السعر	العدد	فتحة الخرطوم		القياسات مم			ملاحظات
PART REF.	PRICE	QTY	HOSE BORE		DIMENSIONS mm			REM.
			DN	INCH	d	D	L	
HT00200 - 20L70			32	1 1/4"	45	56	70	
HT00200 - 20L73			32	1 1/4"	45	56	73	
HT00200 - 20L80			32	1 1/4"	45	56	80	
HT00200 - 24L76			40	1 1/2"	53	62	76	
HT00200 - 32L78			50	2"	65	75	78	

HYDRO – TEC

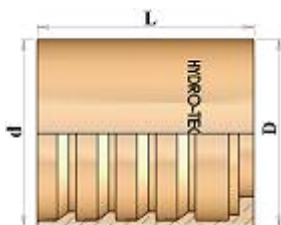

HT01000 SWAGED FERRULE FOR SAE 100 R13 AND R9R DIN 20023 4SP HOSE جلبة (سوكيت) ء طاق ثخين (غليظ) + ٦ طاق

رقم النموذج PART REF.	السعر PRICE	العدد QTY	فتحة الخرطوم HOSE BORE		القياسات مم DIMENSIONS mm			ملاحظات REM.
			DN	INCH	d	D	L	
HT01000 - 04			6	1/4"	15.3	21	30	4SP
- 12			20	3/4"	33	43	60	4SP
- 16			25	1"	39	49	75	4SP
- 20			32	1. 1/4"	46.75	56	66	4SP-R13
- 24			40	1. 1/2"	55.5	67	77	4SP-R13
- 32			50	2"	68.5	80	80	4SP-R13

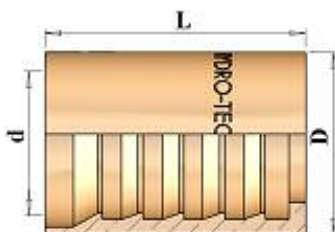

HT09900 SWAGED FERRULE FOR SAE 100 R12 AND R9R DIN 20023 4SP HOSE جلبة (سوكيت) ء طاق ضغط ثقيل

رقم النموذج PART REF.	السعر PRICE	العدد QTY	فتحة الخرطوم HOSE BORE		القياسات مم DIMENSIONS mm			ملاحظات REM.
			DN	INCH	d	D	L	
HT09900 - 06			10	3/8"	18	25	39	4SP-R12
- 08			12	1/2"	22	30	41.5	4SP-R12
- 10			16	5/8"	25.5	34	50	4SP
- 12			20	3/4"	29.5	38	55	4SP-R12
- 16			25	1"	36.5	46	70	4SP-R12

HYDRO – TEC

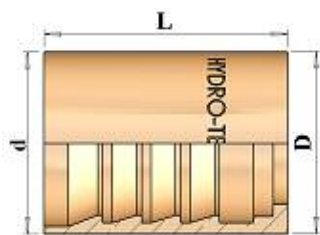

HT00900 SWAGED FERRULE FOR R9R DIN 20023 4SP HOSE

جلبة (سوكيت) ء طاق ضغط عالي

رقم النموذج	السعر	العدد	فتحة الخرطوم		القياسات مم			ملاحظات
PART REF.	PRICE	QTY	HOSE BORE		DIMENSIONS mm			REM.
			DN	INCH	d	D	L	
HT00900 - 12			20	3/4"	29.5	37	50	
- 16			25	1"	36.5	45	60	

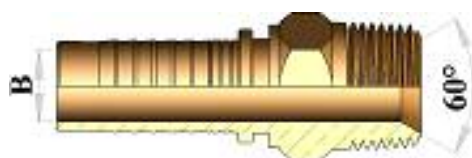

HT10710 BSPT MALE 60° CONE SEAT

ذكر سن BSPT كونيك ٦٠°

	السعر	العدد	فتحة الخرطوم		شرار- سن	القياسات مم		ملاحظات
PART REF.	PRICE	QTY	HOSE BORE		THREAD	DIMENSIONS mm		REM.
			DN	INCH	T	B	H1	
HT10710- 04 - 04			6	1/4"	1/4" - 19	5	14	
- 04 - 06			6	1/4"	3/8" - 19	8	19	
- 05 - 06			8	5/16"	3/8" - 19	8	19	
- 06 - 06			10	3/8"	3/8" - 19	8	19	
- 06 - 08			10	3/8"	1/2" - 14	11.5	22	
- 08 - 08			12	1/2"	1/2" - 14	11.5	22	
- 10 - 12			16	5/8"	3/4" - 14	17	27	
- 12 - 12			19	3/4"	3/4" - 14	17	27	
- 16 - 16			25	1"	1" - 11	22.5	36	
- 20 - 20			31	1. 1/4"	1.1/4" - 11	29	46	
- 24 - 24			38	1. 1/2"	1.1/2" - 11	33.5	50	
-32 - 32			51	2"	2" - 11	46	65	

HYDRO – TEC

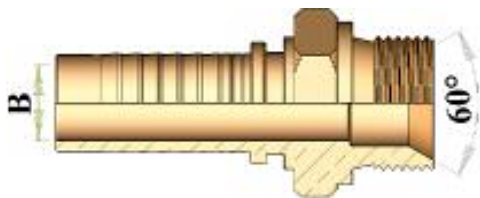

HT10510 BSP MALE PARALLEL 60° CONE SEAT
 ذكر سن BSP مع مركز سيلة كونيك 60°

PART REF.	السعر	العدد	فتحة الخرطوم		شرار- سن	القياسات مم		ملاحظات
	PRICE	QTY	DN	INCH	THREAD	B	H1	REM.
HT10510 - 03 - 02			5	3/16"	1/8" - 28	3.5	14	
- 04 - 02			6	1/4"	1/8" - 28	3.5	14	
- 04 - 04			6	1/4"	1/4" - 19	5	19	
- 04 - 06			6	1/4"	3/8" - 19	8	22	
- 05 - 04			8	5/16"	1/4" - 28	8	19	
- 05 - 06			8	5/16"	3/8" - 19	8	22	
- 06 - 06			10	3/8"	3/8" - 19	8	22	
- 06 - 08			10	3/8"	1/2" - 14	11.5	27	
- 08 - 06			12	1/2"	3/8" - 19	8	22	
- 08 - 08			12	1/2"	1/2" - 14	11.5	27	
- 08 - 10			12	1/2"	5/8" - 14	14.5	30	
- 08 - 12			12	1/2"	3/4" - 14	17	32	
- 10 - 10			16	5/8"	5/8" - 14	14.5	30	
- 10 - 12			16	5/8"	3/4" - 14	17	32	
- 12 - 12			19	3/4"	3/4" - 14	17	32	
- 12 - 16			19	3/4"	1" - 11	22.5	41	
- 16 - 16			25	1"	1" - 11	22.5	41	
- 16 - 20			25	1"	1.1/4" - 11	29	50	
- 20 - 20			31	1. 1/4"	1.1/4" - 11	29	50	
- 20 - 24			31	1. 1/4"	1.1/2" - 11	33.5	55	
- 24 - 24			38	1. 1/2"	1.1/2" - 11	33.5	55	
- 24 - 32			38	1. 1/2"	2" - 11	46	70	
-32 - 32			51	2"	2" - 11	46	70	

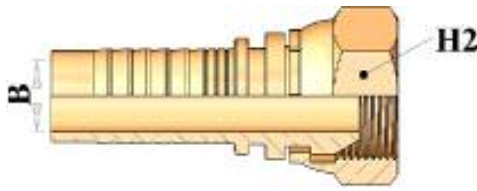

HT20511

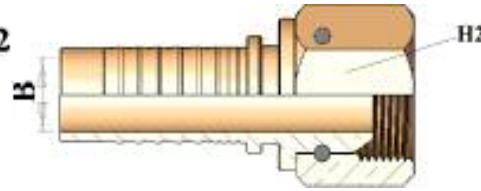

HT20512

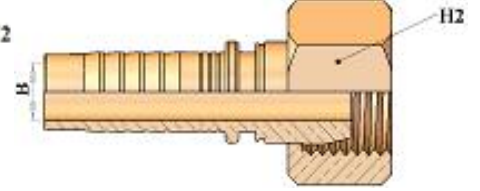

HT20513

HT20511 BSP FEMALE 60° CONE SEAT

متحرك سن BSP عزقة كبس

PART REF.	السعر	العدد	فتحة الخرطوم		شرار - سن	القياسات مم		ملاحظات
	PRICE	QTY	DN	INCH	THREAD	B	H2	REM.
HT20511- 03 -02			5	3/16"	1/8" - 28	3.1	14	
- 03 - 04			5	3/16"	1/4" - 19	4.1	19	
- 04 - 02			6	1/4"	1/8" - 28	4.1	14	
- 04 - 04			6	1/4"	1/4" - 19	4.1	19	
- 04 - 06			6	1/4"	3/8" - 19	7.1	22	
- 05 - 04			8	5/16"	1/4" - 19	4.1	19	
- 05 - 06			8	5/16"	3/8" - 19	7.1	22	
- 06 - 04			10	3/8"	1/4" - 19	4.1	19	
- 06 - 06			10	3/8"	3/8" - 19	7.1	22	
- 06 - 08			10	3/8"	1/2" - 14	9.6	27	
- 08 - 06			12	1/2"	3/8" - 19	7.1	22	
- 08 - 08			12	1/2"	1/2" - 14	9.6	27	
- 08 - 10			12	1/2"	5/8" - 14	12.1	30	
- 08 - 12			12	1/2"	3/4" - 14	15.1	32	
- 10 - 10			16	5/8"	5/8" - 14	12.1	30	
- 10 - 12			16	5/8"	3/4" - 14	15.1	32	
- 12 - 12			19	3/4"	3/4" - 14	15.1	32	
- 12 - 16			19	3/4"	1" - 11	20.1	41	
- 16 - 16			25	1"	1" - 11	20.1	41	
- 16 - 20			25	1"	1.1/4" - 11	26.1	50	
- 20 - 20			31	1. 1/4"	1.1/4" - 11	26.1	50	
- 20 - 24			31	1. 1/4"	1.1/2" - 11	32.1	55	
- 24 - 24			38	1. 1/2"	1.1/2" - 11	32.1	55	
- 24 - 32			38	1. 1/2"	2" - 11	42.1	70	
-32 - 32			51	2"	2" - 11	42.1	70	

يمكن استبدال عزق الكبس HT20511 بعزق كوييل HT20512 أو عزق دك HT20513

MAY INSTED OF CRIMPED NUT HT20511 WITH TRUST-WIRE NUT HT20512 OR WITH SPLIT-ON NUT HT20513

HYDRO – TEC

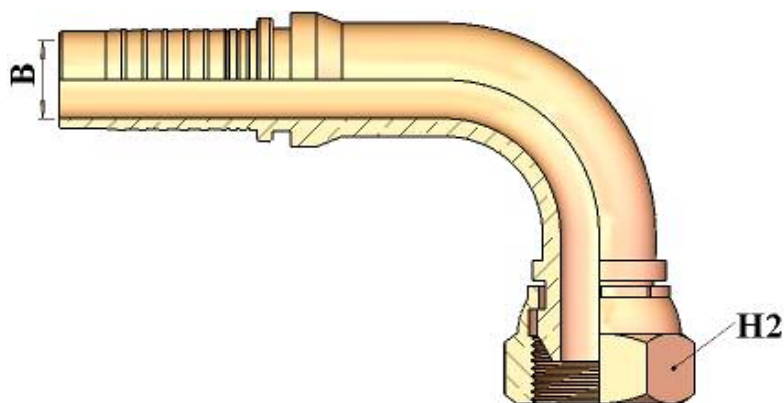

HT20591 90° BSP SWEPT ELBOW 60° CONE

كوع ٩٠ سن BSP عزقة كبس

PART REF.	السعر	العدد	فتحة الخرطوم		شرار- سن	القياسات مم		ملاحظات
	PRICE	QTY	DN	INCH	T	B	H2	REM.
HT20591- 03 - 02			5	3/16"	1/8" - 28	3.1	14	
- 04 - 02			6	1/4"	1/8" - 28	3.1	14	
- 04 - 04			6	1/4"	1/4" - 19	4.1	19	
- 04 - 06			6	1/4"	3/8" - 19	7.1	22	
- 05 - 04			6	5/16"	1/4" - 19	4.1	19	
- 05 - 06			8	5/16"	3/8" - 19	7.1	22	
- 06 - 06			10	3/8"	3/8" - 19	7.1	22	
- 06 - 08			10	3/8"	1/2" - 14	9.6	27	
- 08 - 08			12	1/2"	1/2" - 14	9.6	27	
- 08 - 10			12	1/2"	5/8" - 14	12	30	
- 08 - 12			12	1/2"	3/4" - 14	15	32	
- 10 - 10			16	5/8"	5/8" - 14	12	30	
- 10 - 12			16	5/8"	3/4" - 14	15	32	
- 12 - 12			19	3/4"	3/4" - 14	15	32	
- 12 - 16			19	3/4"	1" - 11	20	41	
- 16 - 16			25	1"	1" - 11	20	41	
- 16 - 20			25	1"	1.1/4" - 11	26	50	
- 20 - 20			31	1. 1/4"	1.1/4" - 11	26	50	
- 20 - 24			31	1. 1/4"	1.1/2" - 11	32	55	
- 24 - 24			38	1. 1/2"	1.1/2" - 11	32	55	
- 24 - 32			38	1. 1/2"	2" - 11	40	70	
-32 - 32			51	2"	2" - 11	40	70	

HYDRO – TEC

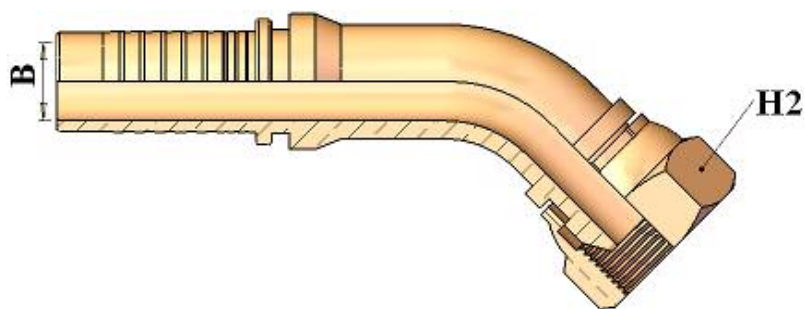

HT20541 45° BSP SWEPT ELBOW 60° CONE
نصف كوع ٤٥° سن BSP عزقة كبس

PART REF.	السعر	العدد	فتحة الخرطوم		شرار - سن	القياسات مم		ملاحظات
	PRICE	QTY	DN	INCH	T	B	H2	REM.
HT20541 - 03 - 02			5	3/16"	1/8" - 28	3.1	14	
- 04 - 02			6	1/4"	1/8" - 28	3.1	14	
- 04 - 04			6	1/4"	1/4" - 19	4.1	19	
- 04 - 06			6	1/4"	3/8" - 19	7.1	22	
- 05 - 06			8	5/16"	3/8" - 19	7.1	22	
- 06 - 06			10	3/8"	3/8" - 19	7.1	22	
- 06 - 08			10	3/8"	1/2" - 14	9.6	27	
- 08 - 08			12	1/2"	1/2" - 14	9.6	27	
- 08 - 10			12	1/2"	5/8" - 14	12.1	30	
- 08 - 12			12	1/2"	3/4" - 14	15.1	32	
- 10 - 10			16	5/8"	5/8" - 14	12.1	30	
- 10 - 12			16	5/8"	3/4" - 14	15.1	32	
- 12 - 12			19	3/4"	3/4" - 14	15.1	32	
- 12 - 16			19	3/4"	1" - 11	20.1	41	
- 16 - 16			25	1"	1" - 11	20.1	41	
- 16 - 20			25	1"	1. 1/4" - 11	26	50	
- 20 - 20			31	1. 1/4"	1.1/4" - 11	26	50	
- 20 - 24			31	1. 1/4"	1.1/2" - 11	32	55	
- 24 - 24			38	1. 1/2"	1.1/2" - 11	32	55	
- 24 - 32			38	1. 1/2"	2" - 11	40	70	
-32 - 32			51	2"	2" - 11	40	70	

HYDRO – TEC

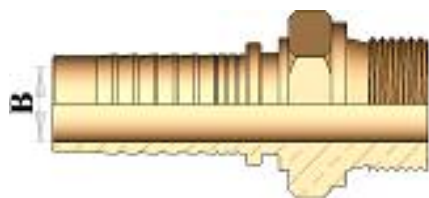

HT10610 BSP MALE FLAT SEAT

ذکر سن BSP وجه مسح

PART REF.	السعر	العدد	فتحة الخرطوم		شرار- سن	القياسات مم		ملاحظات
	PRICE	QTY	HOSE BORE		THREAD	DIMENSIONS mm		REM.
			DN	INCH		T	B	
HT10610 - 04 - 04			6	1/4"	1/4" - 19	4.1	19	
- 06 - 06			10	3/8"	3/8" - 19	7.1	22	
- 06 - 08			10	3/8"	1/2" - 14	7.1	27	
- 08 - 08			12	1/2"	1/2" - 14	9.6	27	
- 10 - 10			16	5/8"	5/8" - 14	12.1	30	
- 12 - 12			19	3/4"	3/4" - 14	15.1	32	
- 16 - 16			25	1"	1" - 11	20.1	41	

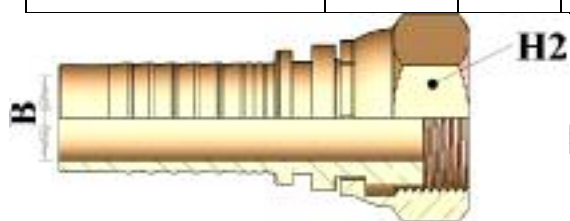

HT20611 BSP FEMALE FLAT SEAT

متحرك سن BSP وجه مسح

PART REF.	السعر	العدد	فتحة الخرطوم		شرار- سن	القياسات مم		ملاحظات
	PRICE	QTY	HOSE BORE		THREAD	DIMENSIONS mm		REM.
			DN	INCH		T	B	
HT20611- 04 - 04			6	1/4"	1/4" - 19	4.1	19	
- 06 - 06			10	3/8"	3/8" - 19	7.1	22	
- 06 - 08			10	3/8"	1/2" - 14	9.6	27	
- 08 - 08			12	1/2"	1/2" - 14	9.6	27	
- 08 - 12			12	1/2"	3/4" - 14	15.1	32	
- 10 - 10			16	5/8"	5/8" - 14	12.1	28	
- 10 - 12			16	5/8"	3/4" - 14	15.1	32	
- 12 - 12			19	3/4"	3/4" - 14	15.1	32	
- 12 - 16			19	3/4"	1" - 11	20.1	38	
- 16 - 16			25	1"	1" - 11	20.1	41	

HYDRO – TEC



HT12810 NPTF MALE 60° CONE SEAT

ذکر سن NPTF كونيك ٦٠°

	السعر	العدد	فتحة الخرطوم		شرار - سن	القياسات مم		ملاحظات
PART REF.	PRICE	QTY	HOSE BORE		THREAD	DIMENSIONS mm		REM.
			DN	INCH	T	B	H1	
HT12810- 03 -02			5	3/16"	1/8" -27	4	12	
- 03 - 04			5	3/16"	1/4" - 18	5.5	14	
- 04 - 02			6	1/4"	1/8" - 27	4	12	
- 04 - 04			6	1/4"	1/4" - 18	5.5	14	
- 04 - 06			6	1/4"	3/8" - 18	9.3	19	
- 04 - 08			8	1/4"	1/2" - 14	9.3	24	
- 05 - 04			8	5/16"	1/4" - 18	5.5	14	
- 05 - 06			8	5/16"	3/8" - 18	9.3	19	
- 06 - 04			10	3/8"	1/4" - 18	5.5	14	
- 06 - 06			10	3/8"	3/8" - 18	9.3	19	
- 06 - 08			10	3/8"	1/2" - 14	12.5	24	
- 08 - 06			12	1/2"	3/8" - 18	9.3	19	
- 08 - 08			12	1/2"	1/2" - 14	12.5	24	
- 08 - 12			12	1/2"	3/4" - 14	16	27	
- 10 - 08			16	5/8"	1/2" - 14	12.5	24	
- 10 - 12			16	5/8"	3/4" - 14	16	27	
- 12 - 08			19	3/4"	1/2" - 14	12.5	27	
- 12 - 12			19	3/4"	3/4" - 14	16	27	
- 12 - 16			19	3/4"	1" - 11.1/2	19.8	36	
- 16 - 12			25	1"	3/4" - 14	15.5	32	
- 16 - 16			25	1"	1" - 11.1/2	19.8	36	
- 16 - 20			25	1"	1. 1/4"- 11.1/2	26	46	
- 20 - 20			31	1. 1/4"	1. 1/4"- 11.1/2	26	46	
- 20 - 24			31	1. 1/4"	1. 1/2"- 11.1/2	32	50	
- 24 - 24			38	1. 1/2"	1. 1/2"- 11.1/2	32	50	
- 24 - 32			38	1. 1/2"	2" - 11.1/2	45	65	
- 32 - 32			51	2"	2" - 11.1/2	45	65	

HYDRO – TEC

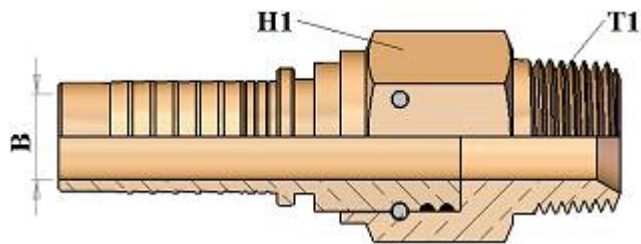

HT14110 NPTF SWIVEL MALL
ذکر متحرك NPTF

PART REF.	السعر	العدد	فتحة الخرطوم		شرار- سن	القياسات مم		ملاحظات
	PRICE	QTY	DN	INCH	T1	B	H1	REM.
HT14110 - 04 - 02			6	1/4"	1/8" - 28	3	17	
- 04 - 04			6	1/4"	1/4" - 19	4	19	
- 04 - 06			6	1/4"	3/8" - 19	7	19	
- 06 - 04			10	3/8"	1/4" - 19	4	22	
- 06 - 06			10	3/8"	3/8" - 19	7	22	
- 06 - 08			10	3/8"	1/2" - 14	9.5	24	
- 08 - 08			12	1/2"	1/2" - 14	9.5	27	
- 12 - 12			19	3/4"	3/4" - 14	16	32	
- 16 - 16			25	1"	1" - 11	20	38	

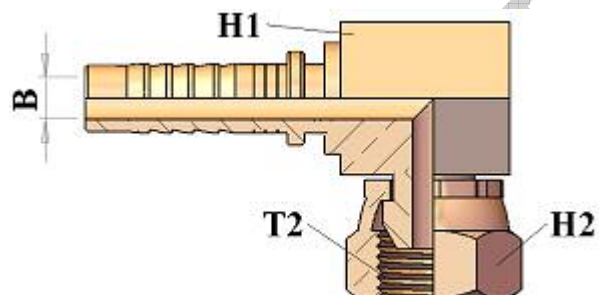

HT20881 90° BSP COMPACT ELBOW
كوع BSP طرق

PART REF.	السعر	العدد	فتحة الخرطوم		شرار- سن	القياسات مم			ملاحظات
	PRICE	QTY	DN	INCH	T2	B	H1	H2	REM.
HT20881 - 04 - 04			6	1/4"	1/4" - 19	4	14	19	
- 06 - 06			10	3/8"	3/8" - 19	7	19	22	
- 08 - 08			12	1/2"	1/2" - 14	9.5	22	27	
- 12 - 12			19	3/4"	3/4" - 14	16	27	32	
- 16 - 16			25	1"	1" - 11	20	36	38	

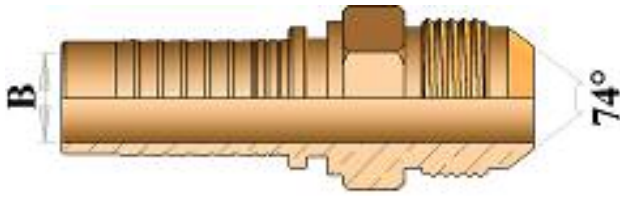

HT12510 JIC MALE 74° CONE
 ذكر سن 74° JIC

PART REF.	السعر	العدد	فتحة الخرطوم		شرار - سن	القياسات مم		ملاحظات
	PRICE	QTY	HOSE BORE		THREAD	DIMENSIONS mm		REM.
			DN	INCH	T	B	H1	
HT12510 - 04 - 04			6	1/4"	7/16" - 20	4.1	12	
- 04 - 05			6	1/4"	1/2" - 20	4.1	13	
- 04 - 06			6	1/4"	9/16" - 18	4.1	15	
- 05 - 05			8	5/16"	1/2" - 20	4.1	14	
- 05 - 06			8	5/16"	9/16" - 18	5.1	15	
- 06 - 06			10	3/8"	9/16" - 18	6.7	15	
- 06 - 08			10	3/8"	3/4" - 16	7.1	19	
- 06 - 10			10	3/8"	7/8" - 14	9.6	24	
- 08 - 08			12	1/2"	3/4" - 16	9.6	19	
- 08 - 10			12	1/2"	7/8" - 14	9.6	24	
- 08 - 12			12	1/2"	1. 1/16" - 12	13	27	
- 10 - 10			16	5/8"	7/8" - 14	12.1	24	
- 10 - 12			16	5/8"	1. 1/16" - 12	15.1	27	
- 12 - 12			19	3/4"	1. 1/16" - 12	15.1	27	
- 12 - 14			19	3/4"	1. 3/16" - 12	16	32	
- 12 - 16			19	3/4"	1. 5/16" - 12	20.1	34	
- 16 - 12			25	1"	1. 1/16" - 12	15.1	32	
- 16 - 16			25	1"	1. 5/16" - 12	20.1	34	
- 16 - 20			25	1"	1. 5/8" - 12	26.1	42	
- 20 - 20			31	1. 1/4"	1. 5/8" - 12	26.1	42	
- 20 - 24			31	1. 1/4"	1.7/8" - 12	32.6	50	
- 24 - 24			38	1. 1/2"	1.7/8" - 12	32.6	50	
- 32 - 32			51	2"	2. 1/2" - 12	44.5	65	

HYDRO – TEC

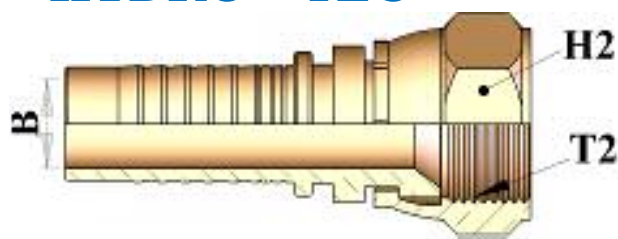

HT22511 JIC FEMALE 74° CONE SEAT

متحرك سن JIC ٧٤° عزقة كبس

PART REF.	السعر	العدد	فتحة الخرطوم		شرار- سن	القياسات مم		ملاحظات
	PRICE	QTY	DN	INCH	T	B	H2	REM.
HT22511- 03 -04			5	3/16"	7/16" - 20	3.1	14	
- 04 - 04			6	1/4"	7/16" - 20	4.1	14	
- 04 - 05			6	1/4"	1/2" - 20	4.1	16	
- 04 - 06			6	1/4"	9/16" - 18	4.1	19	
- 04 - 07			6	1/4"	5/8" - 18	4.1	19	
- 05 - 05			8	5/16"	1/2" - 20	5.1	16	
- 05 - 06			8	5/16"	9/16" - 18	5.1	19	
- 06 - 06			10	3/8"	9/16" - 18	7.1	19	
- 06 - 07			10	3/8"	5/8" - 18	7.1	19	
- 06 - 08			10	3/8"	3/4" - 16	7.1	24	
- 06 - 10			10	3/8"	7/8" - 14	9.5	27	
- 08 - 08			12	1/2"	3/4" - 16	9.6	24	
- 08 - 10			12	1/2"	7/8" - 14	9.6	27	
- 08 - 12			12	1/2"	1. 1/16" - 12	12	32	
- 10 - 10			16	5/8"	7/8" - 14	12.1	27	
- 10 - 12			16	5/8"	1. 1/16" - 12	12.1	32	
- 12 - 10			19	3/4"	7/8" - 14	12	27	
- 12 - 12			19	3/4"	1. 1/16" - 12	15.1	32	
- 12 - 14			19	3/4"	1. 3/16" - 12	16	36	
- 12 - 16			19	3/4"	1. 5/16" - 12	20	41	
- 16 - 12			25	1"	1. 1/16" - 12	15	32	
- 16 - 16			25	1"	1. 5/16" - 12	20.1	41	
- 16 - 20			25	1"	1. 5/8" - 12	26	50	
- 20 - 20			31	1. 1/4"	1. 5/8" - 12	26	50	
- 20 - 24			31	1. 1/4"	1. 7/8" - 12	32	55	
- 24 - 24			38	1. 1/2"	1. 7/8" - 12	32	55	
- 32 - 32			51	2"	2. 1/2" - 12	44	70	

HYDRO - TEC

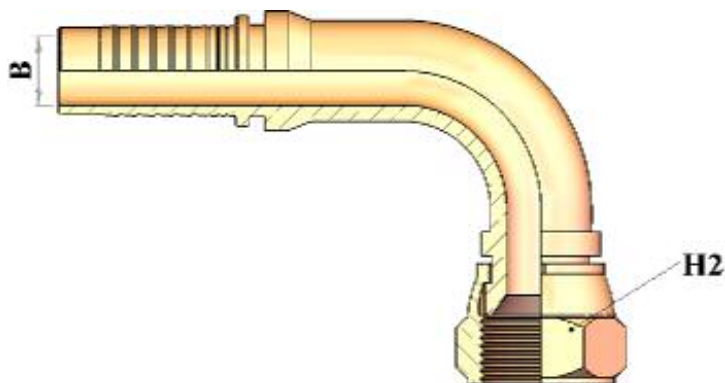

HT22591 90° JIC SWEPT ELBOW 74° CONE

كوع ٩٠ سن JIC ٧٤ عزقة كبس

PART REF.	السعر	العدد	فتحة الخرطوم		شرار - سن	القياسات مم		ملاحظات
	PRICE	QTY	DN	INCH	T	B	H2	REM.
HT22591 - 03 - 04			5	3/16"	7/16" - 20	3.1	14	
- 04 - 04			6	1/4"	7/16" - 20	4.1	14	
- 04 - 05			6	1/4"	1/2" - 20	4.1	16	
- 04 - 06			6	1/4"	9/16" - 18	4.1	19	
- 04 - 07			6	1/4"	5/8" - 18	4.1	19	
- 05 - 06			8	5/16"	9/16" - 18	5.1	19	
- 06 - 06			10	3/8"	9/16" - 18	7.1	19	
- 06 - 07			10	3/8"	5/8" - 18	7.1	19	
- 06 - 08			10	3/8"	3/4" - 16	9.5	24	
- 06 - 10			10	3/8"	7/8" - 14	9.6	27	
- 08 - 08			12	1/2"	3/4" - 16	10	24	
- 08 - 10			12	1/2"	7/8" - 14	13	27	
- 08 - 12			12	1/2"	1. 1/16" - 12	15	32	
- 10 - 10			16	5/8"	7/8" - 14	13	27	
- 10 - 12			16	5/8"	1. 1/16" - 12	15.1	32	
- 12 - 12			19	3/4"	1. 1/16" - 12	15.1	32	
- 12 - 14			19	3/4"	1. 3/16" - 12	16	36	
- 12 - 16			19	3/4"	1. 5/16" - 12	20	41	
- 16 - 16			25	1"	1. 5/16" - 12	20	41	
- 16 - 20			25	1"	1. 5/8" - 12	26	50	
- 20 - 20			31	1. 1/4"	1. 5/8" - 12	26	50	
- 20 - 24			31	1. 1/4"	1. 7/8" - 12	32	55	
- 24 - 24			38	1. 1/2"	1. 7/8" - 12	32	55	
- 32 - 32			51	2"	2. 1/2" - 12	44	70	

HYDRO – TEC

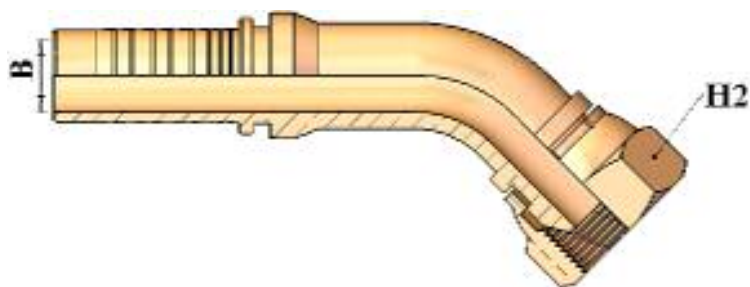

HT22541 45° JIC SWEPT ELBOW 74° CONE
نصف كوع ٤٥° سن JIC ٧٤° عزقة كبس

PART REF.	السعر	العدد	فتحة الخرطوم		شرار - سن	القياسات مم		ملاحظات
	PRICE	QTY	DN	INCH	T	B	H2	REM.
HT22541- 04 - 04			6	1/4"	7/16" - 20	4.1	14	
- 04 - 05			6	1/4"	1/2" - 20	4.1	16	
- 04 - 06			6	1/4"	9/16" - 18	4.1	19	
- 04 - 07			6	1/4"	5/8" - 18	4.1	19	
- 05 - 06			8	5/16"	9/16" - 18	5.1	19	
- 06 - 06			10	3/8"	9/16" - 18	6	19	
- 06 - 07			10	3/8"	5/8" - 18	7.1	19	
- 06 - 08			10	3/8"	3/4" - 16	10	24	
- 06 - 10			10	3/8"	7/8" - 14	13	27	
- 08 - 08			12	1/2"	3/4" - 16	10	24	
- 08 - 10			12	1/2"	7/8" - 14	13	27	
- 08 - 12			12	1/2"	1. 1/16" - 12	15	32	
- 10 - 10			16	5/8"	7/8" - 14	13	27	
- 10 - 12			16	5/8"	1. 1/16" - 12	15	32	
- 12 - 12			19	3/4"	1. 1/16" - 12	15	32	
- 12 - 14			19	3/4"	1. 3/16" - 12	16	36	
- 12 - 16			19	3/4"	1. 5/16" - 12	20	41	
- 16 - 16			25	1"	1. 5/16" - 12	20	41	
- 16 - 20			25	1"	1. 5/8" - 12	26	50	
- 20 - 20			31	1. 1/4"	1. 5/8" - 12	26	50	
- 20 - 24			31	1. 1/4"	1. 7/8" - 12	32	55	
- 24 - 24			38	1. 1/2"	1. 7/8" - 12	32	55	
- 32 - 32			51	2"	2. 1/2" - 12	44	70	

HYDRO – TEC

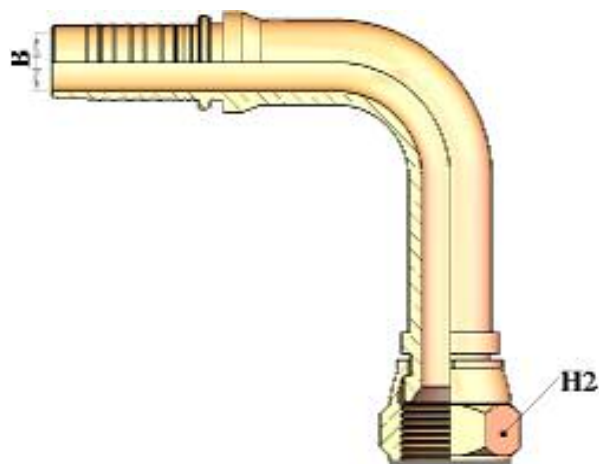

HT24791 90° JIC LONG SWEPT ELBOW 74° CONE

كوع ٩٠ سن JIC طويل ٧٤° عزقة كبس

PART REF.	السعر	العدد	فتحة الخرطوم		شرار- سن	القياسات مم		ملاحظات
	PRICE	QTY	DN	INCH	T2	B	H2	REM.
HT22791 - 04 - 04			6	1/4"	7/16" - 20	4	17	
- 04 - 05			6	1/4"	1/2" - 20	4	17	
- 04 - 06			6	1/4"	9/16" - 18	4	19	
- 06 - 06			10	3/8"	9/16" - 18	7	19	
- 06 - 08			10	3/8"	3/4" - 16	7	22	
- 08 - 08			12	1/2"	3/4" - 16	9.5	22	
- 08 - 10			12	1/2"	7/8" - 14	9.5	27	
- 10 - 10			16	5/8"	7/8" - 14	12.5	27	
- 12 - 12			19	3/4"	1. 1/16" - 12	15	32	
- 16 - 16			25	1"	1. 5/16" - 12	20	38	

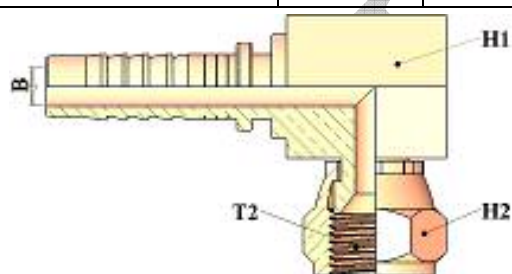

HT22581 90° JIC COMPACT ELBOW

كوع JIC طرق

PART REF.	السعر	العدد	فتحة الخرطوم		شرار- سن	القياسات مم			ملاحظات
	PRICE	QTY	DN	INCH	T2	B	H1	H2	REM.
HT22581 - 06 - 06			10	3/8"	9/16" - 18	6	14	19	
- 08 - 08			12	1/2"	3/4" - 16	10	19	22	
- 10 - 10			16	5/8"	7/8" - 14	12.5	22	27	
- 12 - 12			19	3/4"	1. 1/16" - 12	15	27	32	
- 16 - 16			25	1"	1. 5/16" - 12	20	36	38	

HYDRO – TEC

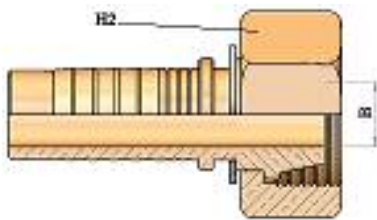

HT21313 METRIC MULTISEAL FEMALE DIN 3868

متحرك مئري عام

PART REF.	السعر	العدد	فتحة الخرطوم		شرار- سن	القياسات مم		ملاحظات	
	PRICE	QTY	HOSE BORE	DN	INCH	THREAD	T	DIMENSIONS mm	REM.
HT21313- 03 -12			5	3/16"	M 12x1.5	3.1	14		
- 04 - 14			6	1/4"	M 14x1.5	4.1	17		
- 04 - 16			6	1/4"	M 16x1.5	4.1	19		
- 05 - 16			8	5/16"	M 16x1.5	5.1	19		
- 05 - 18			8	5/16"	M 18x1.5	5.1	22		
- 06 - 18			10	3/8"	M 18x1.5	7.1	22		
- 06 - 22			10	3/8"	M 22x1.5	7.1	27		
- 08 - 22			12	1/2"	M 22x1.5	9.6	27		
- 10 - 26			16	5/8"	M 26x1.5	12.1	32		

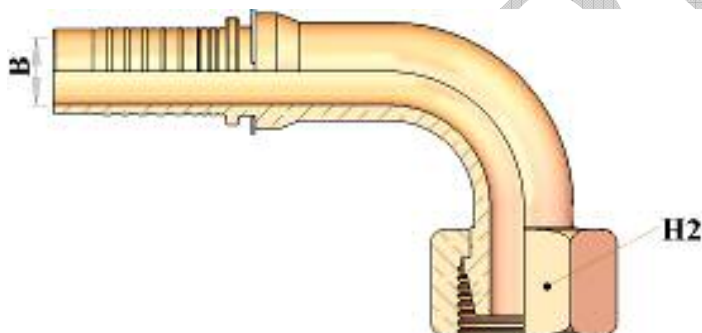

HT21393 90° METRIC SWEPT ELBOW MULTISEAL FEMALE DIN 3868

كوع ٩٠ مئري عام

PART REF.	السعر	العدد	فتحة الخرطوم		شرار- سن	القياسات مم		ملاحظات	
	PRICE	QTY	HOSE BORE	DN	INCH	THREAD	T	DIMENSIONS mm	REM.
HT21393- 03 -12			5	3/16"	M 12x1.5	3.1	14		
- 04 - 14			6	1/4"	M 14x1.5	4.1	17		
- 04 - 16			6	1/4"	M 16x1.5	4.1	19		
- 05 - 16			8	5/16"	M 16x1.5	5.1	19		
- 06 - 18			10	3/8"	M 18x1.5	7.1	22		
- 06 - 22			10	3/8"	M 22x1.5	7.1	27		
- 08 - 22			12	1/2"	M 22x1.5	9.6	27		
- 10 - 26			16	5/8"	M 26x1.5	12.1	32		

HYDRO – TEC

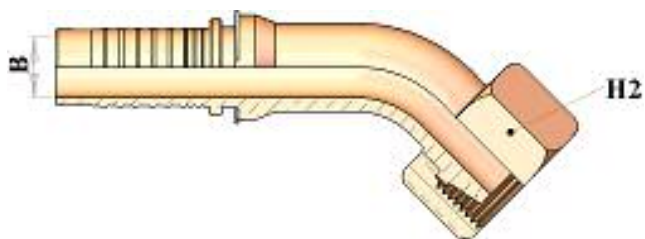

HT21343 45° METRIC SWEPT ELBOW MULTISEAL FEMALE DIN 3868

نصف كوع ٤٥° متري عام

PART REF.	السعر	العدد	فتحة الخرطوم		شرار- سن	القياسات مم		ملاحظات
	PRICE	QTY	HOSE BORE	THREAD	DIMENSIONS mm	REM.		
			DN	INCH	T	B	H2	
HT21343- 03 -12			5	3/16"	M 12x1.5	3.1	14	
- 04 - 14			6	1/4"	M 14x1.5	4.1	17	
- 04 - 16			6	1/4"	M 16x1.5	4.1	19	
- 05 - 16			8	5/16"	M 16x1.5	5.1	19	
- 06 - 18			10	3/8"	M 18x1.5	7.1	22	
- 06 - 22			10	3/8"	M 22x1.5	7.1	27	
- 08 - 22			12	1/2"	M 22x1.5	9.6	27	
- 10 - 26			16	5/8"	M 26x1.5	12.1	32	

HYDRO – TEC

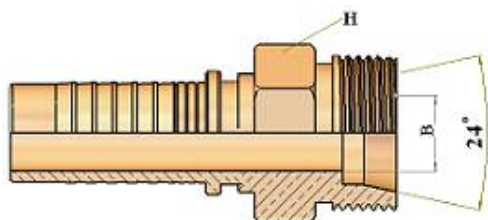

HT11510 METRIC MALE 24° CONE SEAT L.T. DIN 3861

ذکر متري ٢٤ خفيف

PART REF.	السعر	العدد	فتحة الخرطوم		شرار - سن	القياسات مم			ملاحظات
	PRICE	QTY	DN	INCH	T	B	PIPE	H1	REM.
HT11510- 04 -12			6	1/4"	M 12x1.5	4.1	6	14	
- 04 - 14			6	1/4"	M 14x1.5	4.1	8	14	
- 04 - 16			6	1/4"	M 16x1.5	7	10	17	
- 05 - 16			8	5/16"	M 16x1.5	7	10	17	
- 05 - 18			8	5/16"	M 18x1.5	7	12	19	
- 06 - 16			10	3/8"	M 16x1.5	7.1	10	17	
- 06 - 18			10	3/8"	M 18x1.5	7.1	12	19	
- 06 - 22			10	3/8"	M 22x1.5	9.5	15	22	
- 08 - 22			12	1/2"	M 22x1.5	9.6	15	22	
- 08 - 26			12	1/2"	M 26x1.5	9.6	18	27	
- 10 - 26			16	5/8"	M 26x1.5	12.1	18	27	
- 12 - 30			19	3/4"	M 30x2	15.1	22	30	
- 16 - 36			25	1"	M 36x2	20.1	28	36	
- 20 - 45			31	1. 1/4"	M 45x2	26.1	35	46	
- 24 - 52			38	1. 1/2"	M 52x2	32.1	42	55	

HYDRO – TEC

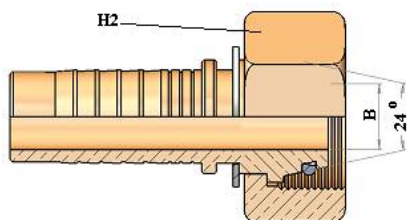

HT21513 O’RING METRIC FEMALE 24° CONE L.T. DIN 3865

متحرك متري ٢٤° بسيلة

PART REF.	السعر	العدد	فتحة الخرطوم		شرار- سن	القياسات مم			ملاحظات
	PRICE	QTY	DN	INCH	T	B	PIPE	H2	REM.
HT21513- 03-12			5	3/16"	M 12x1.5	3.1	6	14	
- 04 - 12			6	1/4"	M 12x1.5	3.1	6	17	CRIMPED
- 04 - 14			6	1/4"	M 14x1.5	4.1	8	17	
- 04 - 16			6	1/4"	M 16x1.5	6	10	19	
- 04 - 18			6	1/4"	M 18x1.5	7.1	12	22	
- 05 - 14			8	5/16"	M 14x1.5	4.1	8	19	CRIMPED
- 05 - 16			8	5/16"	M 16x1.5	6	10	19	
- 05 - 18			8	5/16"	M 18x1.5	7.1	12	22	
- 06 - 16			10	3/8"	M 16x1.5	6	10	22	CRIMPED
- 06 - 18			10	3/8"	M 18x1.5	7.1	12	22	
- 06 - 22			10	3/8"	M 22x1.5	9.6	15	27	
- 08 - 18			12	1/2"	M 18x1.5	7.1	12	24	CRIMPED
- 08 - 22			12	1/2"	M 22x1.5	9.6	15	27	
- 08 - 26			12	1/2"	M 26x1.5	12.1	18	32	
- 10 - 26			16	5/8"	M 26x1.5	12.1	18	32	
- 10 - 30			16	5/8"	M 30x2	15.1	22	36	
- 12 - 26			19	3/4"	M 26x1.5	12.1	18	32	CRIMPED
- 12 - 30			19	3/4"	M 30x2	15.1	22	36	
- 12 - 36			19	3/4"	M 36x2	20.1	28	41	
- 16 - 36			25	1"	M 36x2	20.1	28	41	
- 20 - 45			31	1. 1/4"	M 45x2	26.1	35	50	
- 24 - 52			38	1. 1/2"	M 52x2	32.1	42	60	

HYDRO – TEC

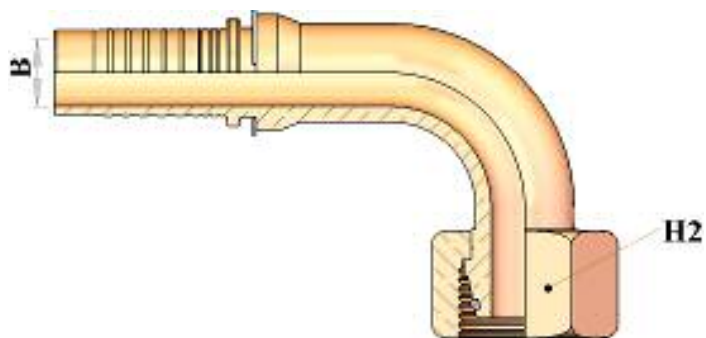

HT21593 90° O’RING METRIC SWEPT ELBOW 24° CONE L.T. DIN 3865
كوع ٩٠ متري ٢٤ بسيلة

PART REF.	السعر	العدد	فتحة الخرطوم		شرار - سن	القياسات مم			ملاحظات
	PRICE	QTY	DN	INCH	T	B	PIPE	H2	REM.
HT21593- 03-12			5	3/16"	M 12x1.5	3.1	6	14	
- 04 - 12			6	1/4"	M 12x1.5	3.1	6	17	CRIMPED
- 04 - 14			6	1/4"	M 14x1.5	4.1	8	17	
- 04 - 16			6	1/4"	M 16x1.5	6	10	19	
- 04 - 18			6	1/4"	M 18x1.5	7.1	12	22	
- 05 - 14			8	5/16"	M 14x1.5	4.1	8	19	CRIMPED
- 05 - 16			8	5/16"	M 16x1.5	6	10	19	
- 05 - 18			8	5/16"	M 18x1.5	7.1	12	22	
- 06 - 16			10	3/8"	M 16x1.5	6	10	22	CRIMPED
- 06 - 18			10	3/8"	M 18x1.5	7.1	12	22	
- 06 - 22			10	3/8"	M 22x1.5	9.6	15	27	
- 08 - 18			12	1/2"	M 18x1.5	7.1	12	24	CRIMPED
- 08 - 22			12	1/2"	M 22x1.5	9.6	15	27	
- 08 - 26			12	1/2"	M 26x1.5	12.1	18	32	
- 10 - 26			16	5/8"	M 26x1.5	12.1	18	32	
- 10 - 30			16	5/8"	M 30x2	15.1	22	36	
- 12 - 26			19	3/4"	M 26x1.5	12.1	18	32	CRIMPED
- 12 - 30			19	3/4"	M 30x2	15.1	22	36	
- 12 - 36			19	3/4"	M 36x2	20.1	28	41	
- 16 - 36			25	1"	M 36x2	20.1	28	41	
- 20 - 45			31	1. 1/4"	M 45x2	26.1	35	50	
- 24 - 52			38	1. 1/2"	M 52x2	32.1	42	60	

HYDRO – TEC

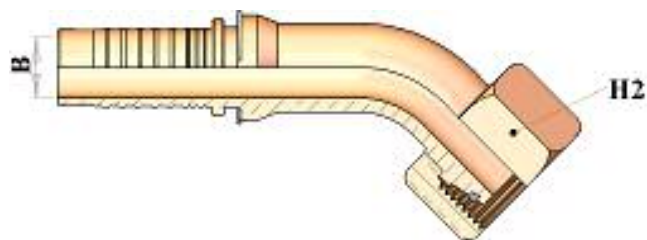

HT21543 90° O’RING METRIC SWEPT ELBOW 24° CONE L.T. DIN 3865

نصف كوع ٤٥° متري ٢٤° بسيلة

PART REF.	السعر	العدد	فتحة الخرطوم		شرار- سن	القياسات مم			ملاحظات
	PRICE	QTY	DN	INCH	T	B	PIPE	H2	REM.
HT21543- 03-12			5	3/16"	M 12x1.5	3.1	6	14	
- 04 - 12			6	1/4"	M 12x1.5	3.1	6	17	CRIMPED
- 04 - 14			6	1/4"	M 14x1.5	4.1	8	17	
- 04 - 16			6	1/4"	M 16x1.5	6	10	19	
- 04 - 18			6	1/4"	M 18x1.5	7.1	12	22	
- 05 - 14			8	5/16"	M 14x1.5	4.1	8	19	CRIMPED
- 05 - 16			8	5/16"	M 16x1.5	6	10	19	
- 05 - 18			8	5/16"	M 18x1.5	7.1	12	22	
- 06 - 16			10	3/8"	M 16x1.5	6	10	12	CRIMPED
- 06 - 18			10	3/8"	M 18x1.5	7.1	12	22	
- 06 - 22			10	3/8"	M 22x1.5	9.6	15	27	
- 08 - 18			12	1/2"	M 18x1.5	7.1	12	24	CRIMPED
- 08 - 22			12	1/2"	M 22x1.5	9.6	15	27	
- 08 - 26			12	1/2"	M 26x1.5	12.1	18	32	
- 10 - 26			16	5/8"	M 26x1.5	12.1	18	32	
- 10 - 30			16	5/8"	M 30x2	15.1	22	36	
- 12 - 26			19	3/4"	M 26x1.5	12.1	18	32	CRIMPED
- 12 - 30			19	3/4"	M 30x2	15.1	22	36	
- 12 - 36			19	3/4"	M 36x2	20.1	28	41	
- 16 - 36			25	1"	M 36x2	20.1	28	41	
- 20 - 45			31	1. 1/4"	M 45x2	26.1	35	50	
- 24 - 52			38	1. 1/2"	M 52x2	32.1	42	60	

HYDRO – TEC

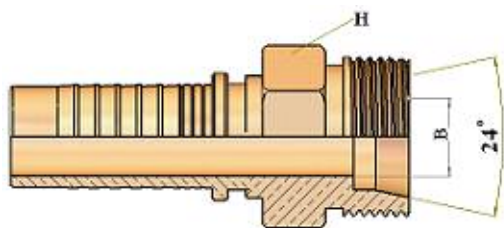

HT11610 O’RING METRIC FEMALE 24° CONE HEAVY DUTY (H.T) DIN 3865
 ذكر متري ٢٤° أعمال ثقيلة

PART REF.	السعر	العدد	فتحة الخرطوم		شرار- سن	القياسات مم			ملاحظات
	PRICE	QTY	DN	INCH	T	B	PIPE	H	REM.
HT11610- 04 -16			6	1/4"	M 16x1.5	4.1	8	17	
- 04 - 18			6	1/4"	M 18x1.5	6	10	19	
- 04 - 20			6	1/4"	M 20x1.5	7.1	12	22	
- 05 - 20			8	5/16"	M 20x1.5	7.1	12	22	
- 06 - 18			10	3/8"	M 18x1.5	7.1	10	19	
- 06 - 20			10	3/8"	M 20x1.5	7.1	12	22	
- 06 - 22			10	3/8"	M 22x1.5	8	14	22	
- 08 - 24			12	1/2"	M 24x1.5	9.6	16	24	
- 10 - 30			16	5/8"	M 30x2	15.1	20	30	
- 12 - 30			19	3/4"	M 30x2	15.1	20	30	
- 12 - 36			19	3/4"	M 36x2	20.1	25	36	
- 16 - 36			25	1"	M 36x2	20.1	25	36	
- 16 - 42			25	1"	M 42x2	25.1	30	46	
- 20 - 52			31	1. 1/4"	M 52x2	30.1	38	55	

HYDRO – TEC

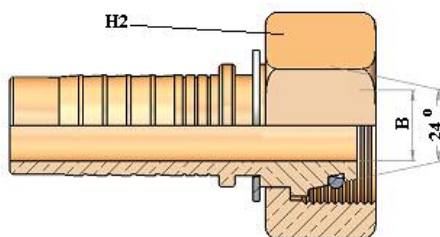

HT21613 O'RING METRIC FEMALE 24° CONE HEAVY DUTY (H.T) DIN 3865

متحرك متري ٢٤° بسيلة أعمال ثقيلة

PART REF.	السعر	العدد	فتحة الخرطوم		شرار- سن	القياسات مم			ملاحظات
	PRICE	QTY	DN	INCH	THREAD T	B	PIPE	H2	REM.
HT21613- 03 -16			5	3/16"	M 16x1.5	3.1	8	19	
- 04 - 14			6	1/4"	M 14x1.5	3.1	6	17	
- 04 - 16			6	1/4"	M 16x1.5	4.1	8	19	
- 04 - 18			6	1/4"	M 18x1.5	4.1	10	22	
- 04 - 20			6	1/4"	M 20x1.5	7.1	12	24	
- 05 - 18			8	5/16"	M 18x1.5	5.5	10	22	
- 05 - 20			8	5/16"	M 20x1.5	5.5	12	24	
- 06 - 20			10	3/8"	M 20x1.5	7.1	12	24	
- 06 - 22			10	3/8"	M 22x1.5	7.1	14	27	
- 08 - 20			12	1/2"	M 20x1.5	9.6	12	27	CRIMPED
- 08 - 24			12	1/2"	M 24x1.5	9.6	16	30	
- 10 - 30			16	5/8"	M 30x2	12.1	20	36	
- 12 - 30			19	3/4"	M 30x2	12.1	20	36	
- 12 - 36			19	3/4"	M 36x2	15.1	25	41	
- 16 - 36			25	1"	M 36x2	15.1	25	41	
- 16 - 42			25	1"	M 42x2	20	30	50	
- 20 - 52			31	1. 1/4"	M 52x2	26	38	60	
- 24 - 52			38	1. 1/2"	M 52x2	26	38	60	

HYDRO – TEC

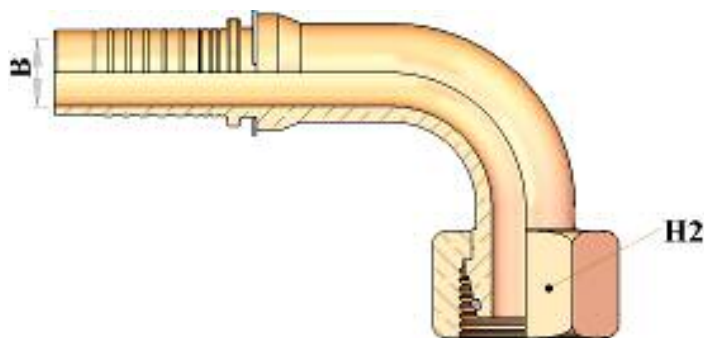

HT21693 90° O’RING METRIC SWEPT ELBOW 24° CONE H.T. DIN 3865

كوع ٩٠ متري ٢٤ بسيلة أعمال ثقيلة

PART REF.	السعر	العدد	فتحة الخرطوم		شرار - سن	القياسات مم			ملاحظات
	PRICE	QTY	DN	INCH	T	B	PIPE	H2	REM.
HT21693- 04 - 14			6	1/4"	M 14x1.5	3.1	6	17	
- 04 - 16			6	1/4"	M 16x1.5	4.1	8	19	
- 04 - 18			6	1/4"	M 18x1.5	4.1	10	22	
- 04 - 20			6	1/4"	M 20x1.5	7.1	12	24	
- 05 - 18			8	5/16"	M 18x1.5	5.5	10	22	
- 05 - 20			8	5/16"	M 20x1.5	5.5	12	24	
- 06 - 20			10	3/8"	M 20x1.5	7.1	12	24	
- 06 - 22			10	3/8"	M 22x1.5	7.1	14	27	
- 06 - 24			10	3/8"	M 24x1.5	9.6	16	30	
- 08 - 20			12	1/2"	M 20x1.5	9.6	12	27	CRIMPED
- 08 - 24			12	1/2"	M 24x1.5	9.6	16	30	
- 10 - 30			16	5/8"	M 30x2	12.1	20	36	
- 12 - 30			19	3/4"	M 30x2	12.1	20	36	
- 12 - 36			19	3/4"	M 36x2	15.1	25	41	
- 16 - 36			25	1"	M 36x2	15.1	25	41	
- 16 - 42			25	1"	M 42x2	20	30	50	
- 20 - 52			31	1. 1/4"	M 52x2	26	38	60	

HYDRO – TEC

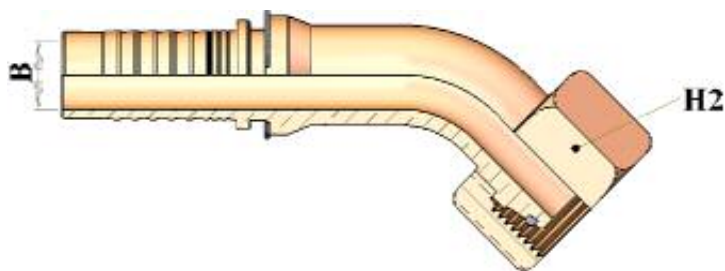

HT21643 45° O’RING METRIC SWEEP ELBOW 24° CONE H.T. DIN 3865

نصف كوع ٤٥° متري ٢٤° بسيلة أعمال ثقيلة

PART REF.	السعر	العدد	فتحة الخرطوم		شرار- سن	القياسات مم			ملاحظات	
	PRICE	QTY	HOSE BORE	DN	INCH	THREAD	T	DIMENSIONS mm	REM.	
							B	PIPE	H2	
HT21643- 04 - 16			6	1/4"	M 16x1.5		4.1	8	19	
- 04 - 18			6	1/4"	M 18x1.5		4.1	10	22	
- 05 - 20			8	5/16"	M 20x1.5		5.5	12	24	
- 06 - 20			10	3/8"	M 20x1.5		7.1	12	24	
- 06 - 22			10	3/8"	M 22x1.5		7.1	14	27	
- 08 - 20			12	1/2"	M 20x1.5		9.6	12	27	CRIMPED
- 08 - 24			12	1/2"	M 24x1.5		9.6	16	30	
- 10 - 30			16	5/8"	M 30x2		12.1	20	36	
- 12 - 30			19	3/4"	M 30x2		12.1	20	36	
- 12 - 36			19	3/4"	M 36x2		15.1	25	41	
- 16 - 36			25	1"	M 36x2		15.1	25	41	
- 16 - 42			25	1"	M 42x2		20	30	50	
- 20 - 52			31	1. 1/4"	M 52x2		26	38	60	

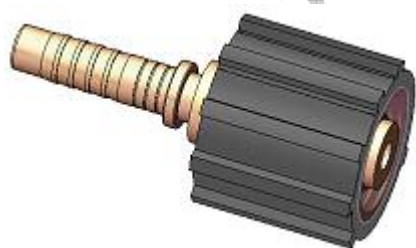

HT24913 WASH CLEANER FEMALE ALUMINUM NUT (TYPE K)

أنثى مغسلة عزقة ألومنيوم

PART REF.	السعر	العدد	فتحة الخرطوم		شرار- سن	القياسات مم		ملاحظات	
	PRICE	QTY	HOSE BORE	DN	INCH	THREAD	T	DIMENSIONS mm	REM.
							B	H2	
HT24913-04 -22			6	1/4"	M 22x1.5		5	27	
- 05 - 22			8	5/16"	M 22x1.5		6	27	
- 06 - 22			10	3/8"	M 22x1.5		7	27	

HYDRO – TEC

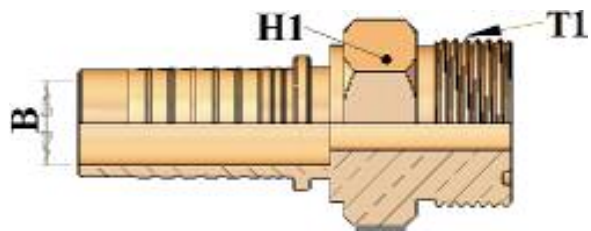

HT12410 OFRS FEMALE
ذکر ORFS

PART REF.	السعر	العدد	فتحة الخرطوم		شرار - سن	القياسات مم		ملاحظات
	PRICE	QTY	DN	INCH	T1	B	H1	REM.
HT12410-04 - 04			6	1/4"	9/16" - 18	4	17	
- 04 - 06			6	1/4"	11/16" - 16	7	22	
- 05 - 06			8	5/16"	11/16" - 16	7	22	
- 06 - 06			10	3/8"	11/16" - 16	7	22	
- 06 - 08			10	3/8"	13/16" - 16	1	24	
- 08 - 08			12	1/2"	13/16" - 16	10	24	
- 08 - 10			12	1/2"	1" - 14	12	30	
- 10 - 10			16	5/8"	1" - 14	12	32	
- 10 - 12			16	5/8"	1.3/16" - 12	15	36	
- 12 - 12			19	3/4"	1.3/16" - 12	15	36	
- 12 - 16			19	3/4"	1.7/16" - 12	20	41	
- 16 - 16			25	1"	1.7/16" - 12	20	41	
- 20 - 20			31	1.1/4"	1.11/16" - 12	26	50	
- 24 - 24			38	1.1/2"	2" - 12	32	60	

HYDRO – TEC

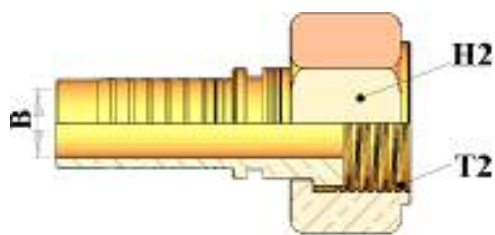

HT22413 OFRS FEMALE متحرك ORFS

PART REF.	السعر	العدد	فتحة الخرطوم		شرار - سن	القياسات مم		ملاحظات
	PRICE	QTY	DN	INCH	T	B	H2	
HT22413-04 - 04			6	1/4"	9/16" - 18	4	17	
- 04 - 06			6	1/4"	11/16" - 16	7	22	
- 05 - 06			8	5/16"	11/16" - 16	7	22	
- 06 - 06			10	3/8"	11/16" - 16	7	22	
- 06 - 08			10	3/8"	13/16" - 16	1	24	
- 08 - 06			12	1/2"	11/16" - 16	7	24	CRIMPED
- 08 - 08			12	1/2"	13/16" - 16	10	24	
- 08 - 10			12	1/2"	1" - 14	12	30	
- 08 - 12			12	1/2"	1. 3/16" - 12	15	36	
- 10 - 10			16	5/8"	1" - 14	12	32	CRIMPED
- 10 - 12			16	5/8"	1. 3/16" - 12	15	36	
- 12 - 10			19	3/4"	1" - 14	12	30	
- 12 - 12			19	3/4"	1. 3/16" - 12	15	36	
- 12 - 16			19	3/4"	1. 7/16" - 12	20	41	
- 16 - 12			25	1"	1. 3/16" - 12	15	36	CRIMPED
- 16 - 16			25	1"	1. 7/16" - 12	20	41	
- 16 - 20			25	1"	1. 11/16" - 12	26	50	
- 20 - 20			31	1. 1/4"	1. 11/16" - 12	26	50	
- 24 - 24			38	1. 1/2"	2" - 12	32	60	

HYDRO – TEC

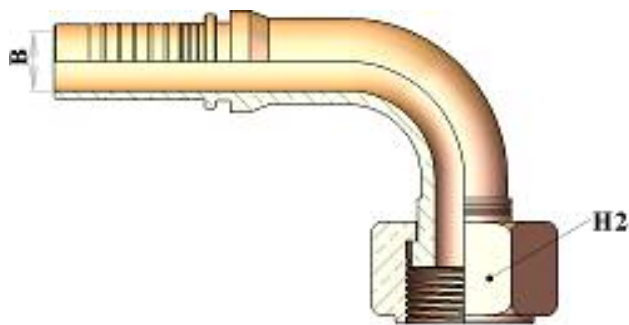

HT22493 90° OFRS FEMALE
ORFS ٩٠ كوع

PART REF.	السعر	العدد	فتحة الخرطوم		شرا- سن	القياسات مم		ملاحظات
	PRICE	QTY	DN	INCH	T	B	H2	REM.
HT22493-04 - 04			6	1/4"	9/16" - 18	4	17	
- 04 - 06			6	1/4"	11/16" - 16	7	22	
- 05 - 06			8	5/16"	11/16" - 16	7	22	
- 06 - 06			10	3/8"	11/16" - 16	7	22	
- 06 - 08			10	3/8"	13/16" - 16	1	24	
- 08 - 06			12	1/2"	11/16" - 16	7	24	CRIMPED
- 08 - 08			12	1/2"	13/16" - 16	10	24	
- 08 - 10			12	1/2"	1" - 14	12	30	
- 08 - 12			12	1/2"	1.3/16" - 12	15	36	
- 10 - 10			16	5/8"	1" - 14	12	30	
- 10 - 12			16	5/8"	1.3/16" - 12	15	36	
- 12 - 10			19	3/4"	1" - 14	12	32	CRIMPED
- 12 - 12			19	3/4"	1.3/16" - 12	15	36	
- 12 - 16			19	3/4"	1.7/16" - 12	20	41	
- 16 - 12			25	1"	1.3/16" - 12	15	36	CRIMPED
- 16 - 16			25	1"	1.7/16" - 12	20	41	
- 16 - 20			25	1"	1.11/16" - 12	26	50	
- 20 - 20			31	1.1/4"	1.11/16" - 12	26	50	
- 24 - 24			38	1.1/2"	2" - 12	32	60	

HYDRO – TEC

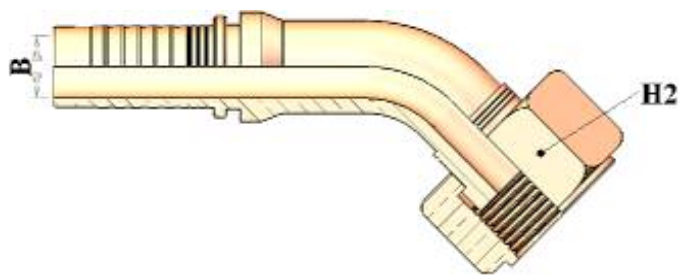

HT22443 45° OFRS FEMALE
ORFS نصف كوع ٤٥°

PART REF.	السعر	العدد	فتحة الخرطوم		شرار - سن	القياسات مم		ملاحظات
	PRICE	QTY	HOSE BORE		THREAD	DIMENSIONS		REM.
			DN	INCH		T	B	
HT22443-04 - 04			6	1/4"	9/16" - 18	4	17	
- 04 - 06			6	1/4"	11/16" - 16	7	22	
- 05 - 06			8	5/16"	11/16" - 16	7	22	
- 06 - 06			10	3/8"	11/16" - 16	7	22	
- 06 - 08			10	3/8"	13/16" - 16	1	24	
- 08 - 06			12	1/2"	11/16" - 16	7	24	CRIMPED
- 08 - 08			12	1/2"	13/16" - 16	10	24	
- 08 - 10			12	1/2"	1" - 14	12	30	
- 08 - 12			12	1/2"	1.3/16" - 12	15	36	
- 10 - 10			16	5/8"	1" - 14	12	30	
- 10 - 12			16	5/8"	1.3/16" - 12	15	36	
- 12 - 10			19	3/4"	1" - 14	12	32	CRIMPED
- 12 - 12			19	3/4"	1.3/16" - 12	15	36	
- 12 - 16			19	3/4"	1.7/16" - 12	20	41	
- 16 - 12			25	1"	1.3/16" - 12	15	36	CRIMPED
- 16 - 16			25	1"	1.7/16" - 12	20	41	
- 16 - 20			25	1"	1.11/16" - 12	26	50	
- 20 - 20			31	1.1/4"	1.11/16" - 12	26	50	
- 24 - 24			38	1.1/2"	2" - 12	32	60	

HYDRO – TEC

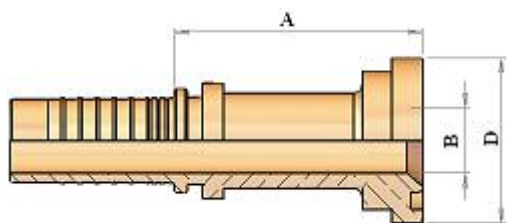

HT24111 STRAIGHT JIS FLANGE (JAPANESE TYPE)

مستقيم فلنجة ياباني

PART REF.	السعر	العدد	فتحة الخرطوم		قياس الفلانجة	القياسات مم		ملاحظات
	PRICE	QTY	HOSE BORE		FLANGE	DIMENSIONS mm		REM.
			DN	INCH	INCH	B	D	
HT24111- 10 - 10			16	5/8"	5/8"	14	34	

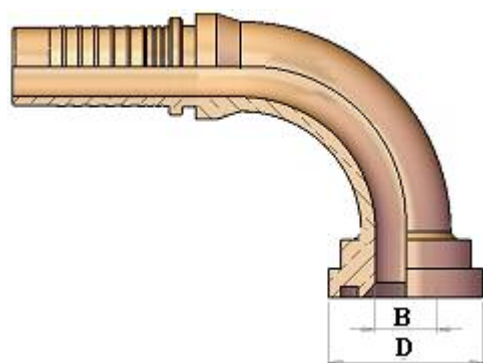

HT24190 90° JIS FLANGE (JAPANESE TYPE)

٩٠ كوع فلنجة ياباني

PART REF.	السعر	العدد	فتحة الخرطوم		قياس الفلانجة	القياسات مم		ملاحظات
	PRICE	QTY	HOSE BORE		FLANGE	DIMENSIONS mm		REM.
			DN	INCH	INCH	B	D	
HT24190- 10 - 10			16	5/8"	5/8"	14	34	

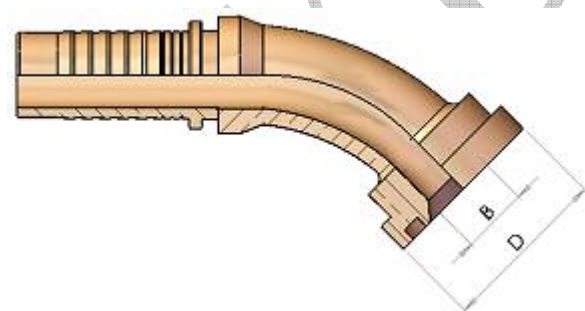

HT24145 45° JIS FLANGE (JAPANESE TYPE)

نصف كوع ٤٥° فلنجة ياباني

PART REF.	السعر	العدد	فتحة الخرطوم		قياس الفلانجة	القياسات مم		ملاحظات
	PRICE	QTY	HOSE BORE		FLANGE	DIMENSIONS mm		REM.
			DN	INCH	INCH	B	D	
HT24145- 10 - 10			16	5/8"	5/8"	14	34	

HYDRO – TEC

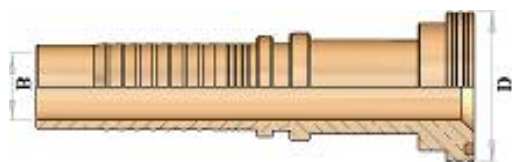

NORMAL

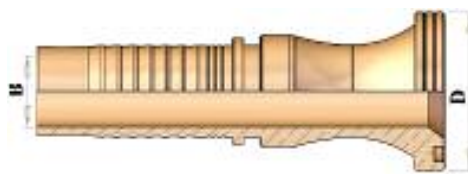

WITH R

HT23311 STRAIGHT FLANGE 3000 P.S.I. مستقيم فلانج قطعة واحدة 3000 P.S.I.

PART REF.	السعر	العدد	فتحة الخرطوم		قياس الفلنجة	القياسات مم		ملاحظات
	PRICE	QTY	HOSE BORE	FLANGE	DIMENSIONS mm	REM.		
			DN	INCH	INCH	B	D	
HT23311- 08 -08			12	1/2"	1/2"	9.3	30.2	
- 08 - 12			12	1/2"	3/4"	15	38	
- 10 - 12			16	5/8"	3/4"	15	38	
- 12 - 12			19	3/4"	3/4"	15	38	
- 12 - 16			19	3/4"	1"	20	44.5	
- 16 - 16			25	1"	1"	20	44.5	
- 16 - 20			25	1"	1. 1/4"	25	50.8	
- 20 - 20			31	1. 1/4"	1. 1/4"	25	50.8	
- 20 - 24			31	1. 1/4"	1. 1/2"	30	60.3	
- 24 - 24			38	1. 1/2"	1. 1/2"	30	60.3	
- 24 - 32			38	1. 1/2"	2"	42	71.4	
- 32 - 32			51	2"	2"	42	71.4	
- 32 - 40			51	2"	2. 1/2"	56	84.1	
- 38 - 40			60	2. 3/8"	2. 1/2"	56	84.1	
- 40 - 40			63	2. 1/2"	2. 1/2"	56	84.1	
- 48 - 48			76	3"	3"	67	101.6	

HYDRO – TEC

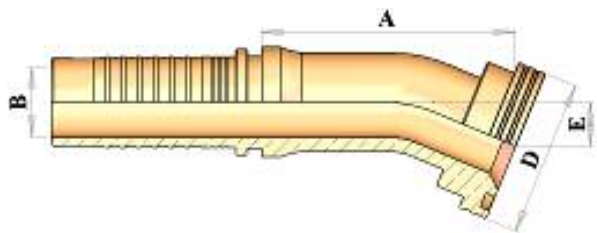

HT23322 22.5° FLANGE 3000 P.S.I.
فلانج زاوية ٢٢.٥ ° قطعة واحدة 3000 P.S.I.

PART REF.	السعر	العدد	فتحة الخرطوم		قياس الفلنجة	القياسات مم		ملاحظات
	PRICE	QTY	DN	INCH	INCH	B	D	REM.
HT23322- 08 -08			12	1/2"	1/2"	9.3	30.2	
- 12 - 12			19	3/4"	3/4"	15	38	
- 12 - 16			19	3/4"	1"	20	44.5	
- 16 - 16			25	1"	1"	20	44.5	
- 20 - 20			31	1. 1/4"	1. 1/4"	25	50.8	
- 20 - 24			31	1. 1/4"	1. 1/2"	30	60.3	

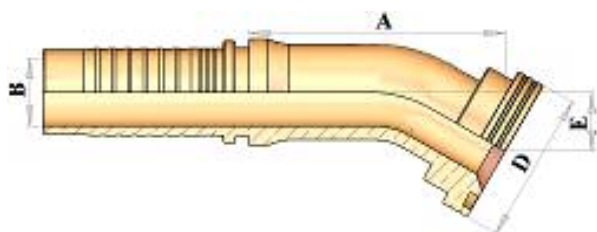

HT23330 30° FLANGE 3000 P.S.I.
فلانج زاوية ٣٠ ° قطعة واحدة 3000 P.S.I.

PART REF.	السعر	العدد	فتحة الخرطوم		قياس الفلنجة	القياسات مم		ملاحظات
	PRICE	QTY	DN	INCH	INCH	B	D	REM.
HT23330- 08 -08			12	1/2"	1/2"	9.3	30.2	
- 12 - 12			19	3/4"	3/4"	15	38	
- 12 - 16			19	3/4"	1"	20	44.5	
- 16 - 16			25	1"	1"	20	44.5	
- 20 - 20			31	1. 1/4"	1. 1/4"	25	50.8	
- 24 - 24			38	1. 1/2"	1. 1/2"	30	60.3	

HYDRO – TEC

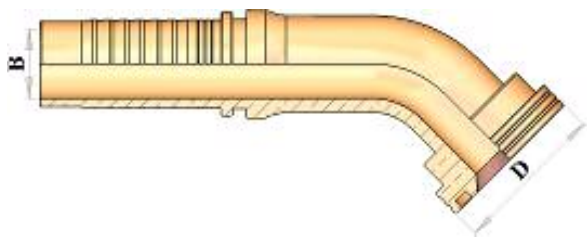

HT23345 45° FLANGE 3000 P.S.I.
 نصف كوع ٤٥° فلانج قطعة واحدة 3000 P.S.I.

PART REF.	السعر	العدد	فتحة الخرطوم		قياس الفلانة	القياسات مم		ملاحظات
	PRICE	QTY	DN	INCH	INCH	B	D	REM.
HT23345- 08 -08			12	1/2"	1/2"	9.3	30.2	
- 08 - 12			12	1/2"	3/4"	15	38	
- 10 - 12			16	5/8"	3/4"	15	38	
- 12 - 12			19	3/4"	3/4"	15	38	
- 12 - 16			19	3/4"	1"	20	44.5	
- 16 - 16			25	1"	1"	20	44.5	
- 16 - 20			25	1"	1. 1/4"	25	50.8	
- 20 - 20			31	1. 1/4"	1. 1/4"	25	50.8	
- 20 - 24			31	1. 1/4"	1. 1/2"	30	60.3	
- 24 - 24			38	1. 1/2"	1. 1/2"	30	60.3	
- 24 - 32			38	1. 1/2"	2"	42	71.4	
- 32 - 32			51	2"	2"	42	71.4	

HYDRO – TEC

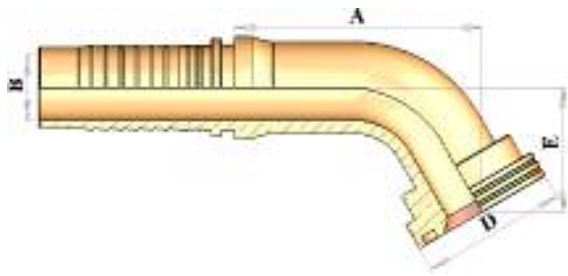

HT23360 60° FLANGE 3000 P.S.I.
فلانج زاوية ٦٠° قطعة واحدة 3000 P.S.I.

PART REF.	السعر	العدد	فتحة الخرطوم		قياس الفلانة	القياسات مم		ملاحظات
	PRICE	QTY	DN	INCH	INCH	B	D	REM.
HT23360- 08 -08			12	1/2"	1/2"	9.3	30.2	
- 12 - 12			19	3/4"	3/4"	15	38	
- 16 - 16			25	1"	1"	20	44.5	
- 16 - 20			25	1"	1. 1/4"	25	50.8	
- 20 - 20			31	1. 1/4"	1. 1/4"	25	50.8	
- 20 - 24			31	1. 1/4"	1. 1/2"	30	60.3	
- 24 - 24			38	1. 1/2"	1. 1/2"	30	60.3	

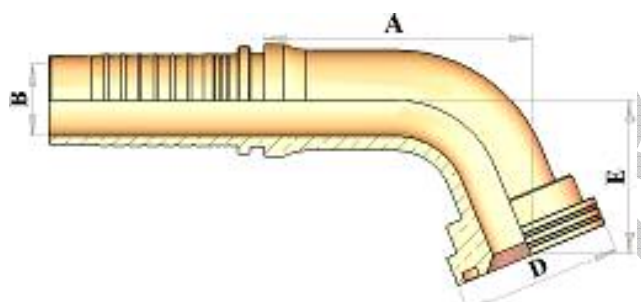

HT23367 67.5° FLANGE 3000 P.S.I.
فلانج زاوية ٦٧.٥° قطعة واحدة 3000 P.S.I.

PART REF.	السعر	العدد	فتحة الخرطوم		قياس الفلانة	القياسات مم		ملاحظات
	PRICE	QTY	DN	INCH	INCH	B	D	REM.
HT23367- 08 -08			12	1/2"	1/2"	9.3	30.2	
- 12 - 12			19	3/4"	3/4"	15	38	
- 12 - 16			19	3/4"	1"	20	44.5	
- 16 - 16			25	1"	1"	20	44.5	
- 20 - 20			31	1. 1/4"	1. 1/4"	25	50.8	
- 24 - 24			38	1. 1/2"	1. 1/2"	30	60.3	

HYDRO – TEC

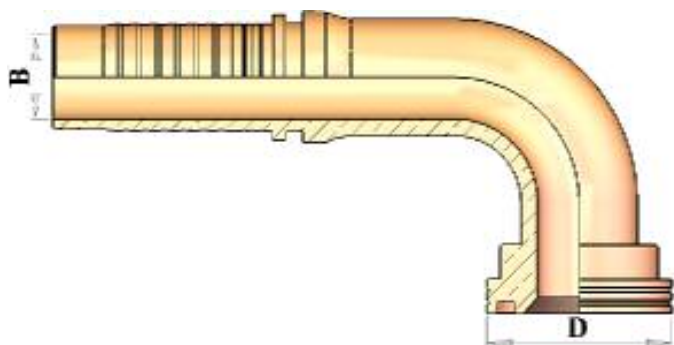

HT23390 90° FLANGE 3000 P.S.I.
كوع ٩٠° فلانج قطعة واحدة 3000 P.S.I.

PART REF.	السعر	العدد	فتحة الخرطوم		قياس الفلنجة	القياسات مم		ملاحظات
	PRICE	QTY	DN	INCH	FLANGE INCH	B	D	REM.
HT23390- 08 -08			12	1/2"	1/2"	9.3	30.2	
- 08 - 12			12	1/2"	3/4"	15	38	
- 10 - 12			16	5/8"	3/4"	15	38	
- 12 - 12			19	3/4"	3/4"	15	38	
- 12 - 16			19	3/4"	1"	20	44.5	
- 16 - 16			25	1"	1"	20	44.5	
- 16 - 20			25	1"	1. 1/4"	25	50.8	
- 20 - 20			31	1. 1/4"	1. 1/4"	25	50.8	
- 20 - 24			31	1. 1/4"	1. 1/2"	30	60.3	
- 24 - 24			38	1. 1/2"	1. 1/2"	30	60.3	
- 24 - 32			38	1. 1/2"	2"	42	71.4	
- 32 - 32			51	2"	2"	42	71.4	
- 40 - 40			63	2. 1/2"	2. 1/2"	52	84.1	
- 48 - 48			76	3"	3"	61	101.6	

HYDRO - TEC

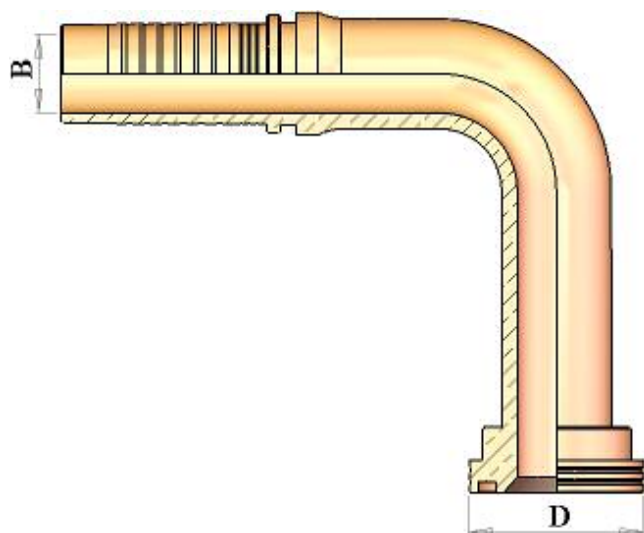

HT23390L 90° LONG DROP FLANGE 3000 P.S.I.
كوع فلانج ٩٠° طويل قطعة واحدة 3000 P.S.I.

PART REF.	السعر	العدد	فتحة الخرطوم		قياس الفلانجة	القياسات مم		ملاحظات
	PRICE	QTY	HOSE BORE		FLANGE	DIMENSIONS mm		REM.
			DN	INCH	INCH	B	D	
HT23390- 12 - 12L100			19	3/4"	3/4"	15	38	
- 12 - 12L110			19	3/4"	3/4"	15	38	
- 12 - 12L115			19	3/4"	3/4"	15	38	
- 12 - 16L			19	3/4"	1"	20	44.5	
- 16 - 16L			25	1"	1"	20	44.5	
- 16 - 16L			25	1"	1"	20	44.5	
- 16 - 16L			25	1"	1"	20	44.5	
- 16 - 20L117			25	1"	1. 1/4"	25	50.8	
- 16 - 24L107			25	1"	1. 1/2"	25	60	
- 20 - 20L091			31	1. 1/4"	1. 1/4"	25	50.8	
- 20 - 20L100			31	1. 1/4"	1. 1/4"	25	50.8	
- 20 - 20L112			31	1. 1/4"	1. 1/4"	25	50.8	
- 20 - 20L130			31	1. 1/4"	1. 1/4"	25	50.8	
- 20 - 20L168			31	1. 1/4"	1. 1/4"	25	50.8	
- 20 - 24L118			31	1. 1/4"	1. 1/2"	32	60	
- 20 - 24L130			31	1. 1/4"	1. 1/2"	32	60	
- 24 - 24L148			38	1. 1/2"	1. 1/2"	32	60	
- 24 - 24L172			38	1. 1/2"	1. 1/2"	32	60	
- 24 - 32L115			38	1. 1/2"	2"	42	70	
- 24 - 32L172			38	1. 1/2"	2"	42	70	
- 32 - 32L203			51	2"	2"	42	70	

HYDRO – TEC

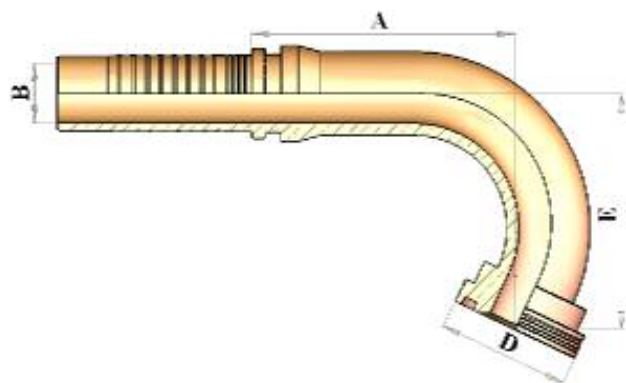

HT233110 110° FLANGE 3000 P.S.I.
فلانج قطعة واحدة ١١٠° 3000 P.S.I.

PART REF.	السعر	العدد	فتحة الخرطوم		قياس الفلانجة	القياسات مم				ملاحظات
	PRICE	QTY	DN	INCH	FLANGE INCH	B	D	A	E	REM.
HT233110- 08 - 12			12	1/2"	3/4"	15	38	47.5	48.5	
- 12 - 12			19	3/4"	3/4"	15	38	89	62	
- 12 - 16			19	3/4"	1"	20	44.5	89	62	
- 16 - 16			25	1"	1"	20	44.5	88.5	79	
- 16 - 20			25	1"	1. 1/4"	25	50.8	77	133	
- 20 - 20			31	1. 1/4"	1. 1/4"	25	50.8	102	89	
- 20 - 24			31	1. 1/4"	1. 1/2"	30	60.3	108.5	93	
- 24 - 24			38	1. 1/2"	1. 1/2"	30	60.3	105.5	119	
- 32 - 32			51	2"	2"	42	71.4	142	123	

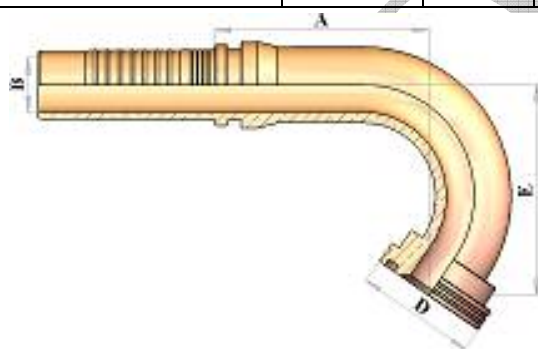

HT233125 125° FLANGE 3000 P.S.I.
فلانج قطعة واحدة ١٢٥° 3000 P.S.I.

PART REF.	السعر	العدد	فتحة الخرطوم		قياس الفلانجة	القياسات مم				ملاحظات
	PRICE	QTY	DN	INCH	FLANGE INCH	B	D	A	E	REM.
HT233135- 12 - 12T			19	3/4"	3/4"	15	38			
- 12 - 16T			19	3/4"	1"	20	44.5			
- 16 - 16T			25	1"	1"	20	44.5			
-32 - 32			51	2"	2"	42	71.6	118.5	151	

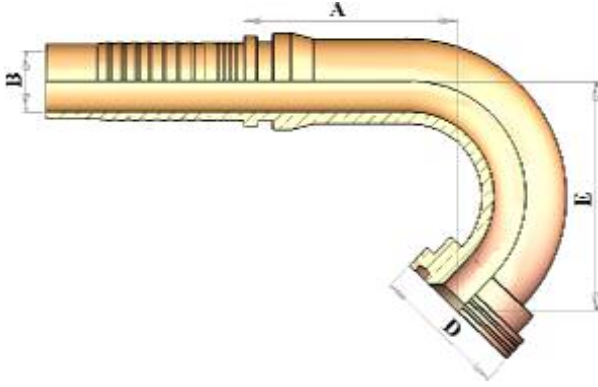

HT233135 135° FLANGE 3000 P.S.I.
 فلانج قطعة واحدة ١٣٥° 3000 P.S.I.

PART REF.	السعر	العدد	فتحة الخرطوم		قياس الفلانجة	القياسات مم				ملاحظات
	PRICE	QTY	DN	INCH	INCH	B	D	A	E	REM.
HT233135- 12 – 12T			19	3/4"	3/4"	15	38	74.5	70	
- 12 – 16T			19	3/4"	1"	20	44.5	74.5	70	
- 16 – 16T			25	1"	1"	20	44.5	70	88.5	

HYDRO – TEC

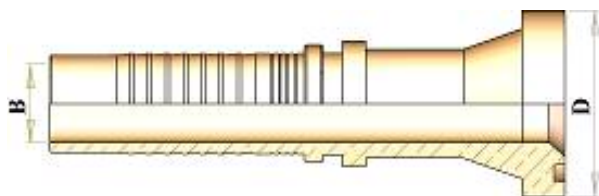

HT23611 STRAIGHT FLANGE 6000 P.S.I.
مستقيم فلانج قطعة واحدة 6000 P.S.I.

PART REF.	السعر	العدد	فتحة الخرطوم		قياس الفلانجة	القياسات مم		ملاحظات
	PRICE	QTY	HOSE BORE		FLANGE	DIMENSIONS mm		REM.
			DN	INCH	INCH	B	D	
HT23611- 08 -08			12	1/2"	1/2"	9.3	31.8	
- 08 - 12			12	1/2"	3/4"	15	41.3	
- 10 - 08			16	5/8"	1/2"	9.3	31.8	
- 10 - 12			16	5/8"	3/4"	15	41.3	
- 12 - 12			19	3/4"	3/4"	15	41.3	
- 12 - 16			19	3/4"	1"	20	47.5	
- 16 - 16			25	1"	1"	20	47.5	
- 16 - 20			25	1"	1. 1/4"	25	54	
- 20 - 20			31	1. 1/4"	1. 1/4"	25	54	
- 20 - 24			31	1. 1/4"	1. 1/2"	30	63.5	
- 24 - 24			38	1. 1/2"	1. 1/2"	30	63.5	
- 24 - 32			38	1. 1/2"	2"	42	79.5	
- 32 - 32			51	2"	2"	42	79.5	

HYDRO – TEC

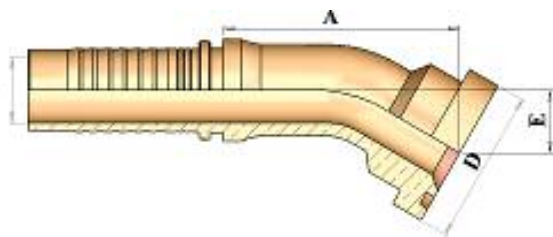

HT23630 30° FLANGE 6000 P.S.I.
6000 P.S.I. ٣٠ درجة قطعة واحدة

PART REF.	السعر	العدد	فتحة الخرطوم		قياس الفلانة	القياسات مم				ملاحظات
	PRICE	QTY	HOSE BORE	FLANGE	DIMENSIONS mm	B	D	A	E	REM.
			DN	INCH	INCH					
HT23630- 12 – 12T			19	3/4"	3/4"	16	41.5	87	17.5	
- 16 – 16T			25	1"	1"	20	47.7	98.5	20	
- 20 – 20T			31	1. 1/4"	1. 1/4"	26	54	115.5	23	
- 24 – 24T			38	1. 1/2"	1. 1/2"	32	63.6	133.5	27	
- 32 – 32T			51	2"	2"	42	79.5	166.5	60.5	

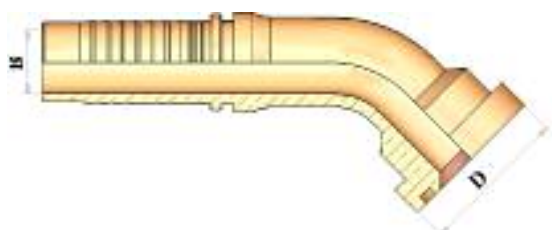

HT23645 45° FLANGE 6000 P.S.I.
6000 P.S.I. نصف كوع ٤٥ درجة قطعة واحدة

PART REF.	السعر	العدد	فتحة الخرطوم		قياس الفلانة	القياسات مم		ملاحظات
	PRICE	QTY	HOSE BORE	FLANGE	DIMENSIONS mm	B	D	REM.
			DN	INCH	INCH			
HT23645- 08 -08			12	1/2"	1/2"	9.3	31.8	
- 08 - 12			12	1/2"	3/4"	15	41.3	
- 10 - 12			16	5/8"	3/4"	15	41.3	
- 12 - 12			19	3/4"	3/4"	15	41.3	
- 12 - 16			19	3/4"	1"	20	47.5	
- 16 - 12			19	1"	3/4"	15	41.3	
- 16 - 16			25	1"	1"	20	47.5	
- 16 - 20			25	1"	1. 1/4"	25	54	
- 20 - 20			31	1. 1/4"	1. 1/4"	25	54	
- 20 - 24			31	1. 1/4"	1. 1/2"	30	63.5	
- 24 - 24			38	1. 1/2"	1. 1/2"	30	63.5	
- 24 - 32			38	1. 1/2"	2"	42	79.5	
- 32 - 32			51	2"	2"	42	79.5	

HYDRO – TEC

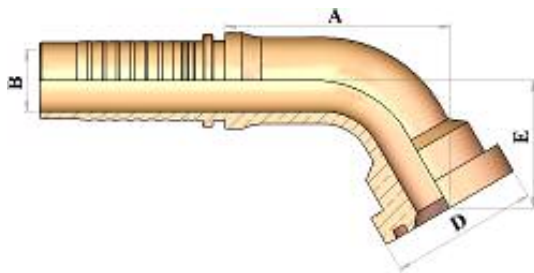

HT23660 60° FLANGE 6000 P.S.I.
6000 P.S.I. °٦٠ فلانج قطعة واحدة

PART REF.	السعر	العدد	فتحة الخرطوم		قياس الفلانجة	القياسات مم				ملاحظات
	PRICE	QTY	DN	INCH	INCH	B	D	A	E	REM.
HT23660- 12 – 12T			19	3/4"	3/4"	16	41.5	98.5	39	
- 12 – 16T			19	3/4"	1"	20	47.7	101.5	44	
- 16 – 16T			25	1"	1"	20	47.7	107.5	52	
- 20 – 20T			31	1. 1/4"	1. 1/4"	26	54	130	59	
- 20 – 24T			31	1. 1/4"	1. 1/2"	32	63.6	136	67.5	
- 24 – 24T			38	1. 1/2"	1. 1/2"	32	63.6	154	61.5	
- 32 – 32T			51	2"	2"	42	79.5	197.5	85	

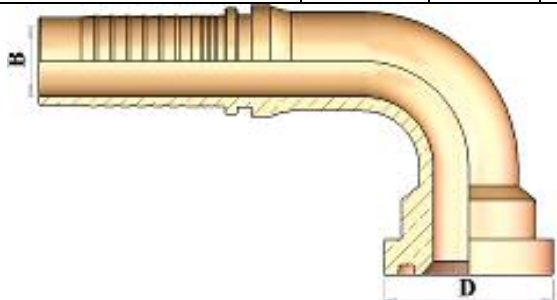

HT23690 90° FLANGE 6000 P.S.I.
كوع ٩٠° فلانج قطعة واحدة 6000 P.S.I.

PART REF.	السعر	العدد	فتحة الخرطوم		قياس الفلانجة	القياسات مم		ملاحظات
	PRICE	QTY	DN	INCH	INCH	B	D	REM.
HT23690- 08 -08			12	1/2"	1/2"	9.3	31.8	
- 08 - 12			12	1/2"	3/4"	15	41.3	
- 10 - 08			16	5/8"	1/2"	9.3	31.8	
- 10 - 12			16	5/8"	3/4"	15	41.3	
- 12 - 12			19	3/4"	3/4"	15	41.3	
- 12 - 16			19	3/4"	1"	20	47.5	
- 16 - 16			25	1"	1"	20	47.5	
- 16 - 20			25	1"	1. 1/4"	25	54	
- 20 - 20			31	1. 1/4"	1. 1/4"	25	54	
- 20 - 24			31	1. 1/4"	1. 1/2"	30	63.5	
- 24 - 24			38	1. 1/2"	1. 1/2"	30	63.5	
- 24 - 32			38	1. 1/2"	2"	42	79.5	
- 32 - 32			51	2"	2"	42	79.5	

HYDRO - TEC

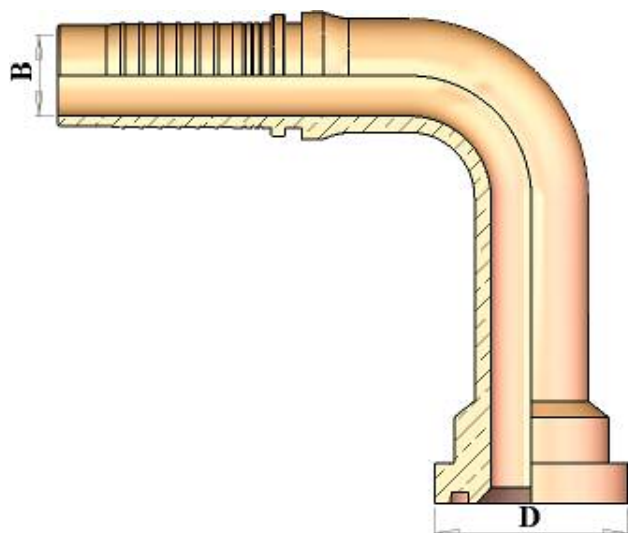

HT23690L 90° LONG DROP FLANGE 6000 P.S.I.
كوع فلانج ٩٠° طويل قطعة واحدة 6000 P.S.I.

PART REF.	السعر	العدد	فتحة الخرطوم		قياس الفلانجة	القياسات مم		ملاحظات
	PRICE	QTY	HOSE BORE	FLANGE	DIMENSIONS mm	REM.		
			DN	INCH	INCH	B	D	
HT23690- 12 - 12L			19	3/4"	3/4"	15	41.3	
- 12 - 16L			19	3/4"	1"	20	47.5	
- 16 - 16L			25	1"	1"	20	47.5	
- 16 - 20L			25	1"	1. 1/4"	25	54	
- 20 - 20L			31	1. 1/4"	1. 1/4"	25	54	
- 20 - 24L			31	1. 1/4"	1. 1/2"	30	63.5	
- 24 - 24L			38	1. 1/2"	1. 1/2"	30	63.5	

HYDRO – TEC

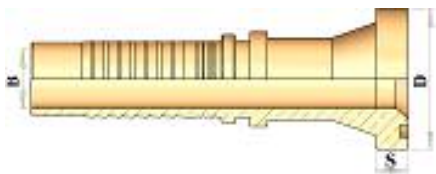

HT23711 L.L LITTLE LONG DROP STRAIGHT FLANGE 6000 P.S.I.
6000 P.S.I. مستقيم فلانج طويل قليلاً قطعة واحدة

PART REF.	السعر	العدد	فتحة الخرطوم		قياس الفلانجة	القياسات مم			ملاحظات
	PRICE	QTY	HOSE BORE	FLANGE	DIMENSIONS mm	B	D	S	REM.
			DN	INCH	INCH				
HT23611- 10 – 12L.L			16	5/8"	3/4"	15	41.3	9	
- 12 - 12L.L			19	3/4"	3/4"	15	41.3	10	
- 16 - 16L.L			25	1"	1"	20	47.5	11	
- 20 - 20L.L			31	1. 1/4"	1. 1/4"	25	54	12	

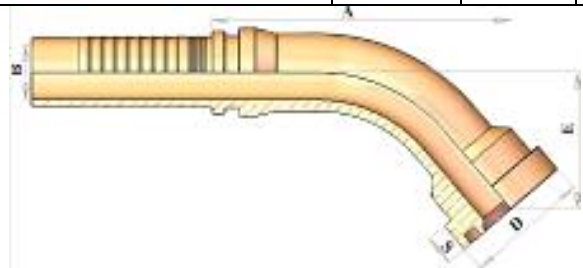

HT23745L.L 45° LITTLE LONG DROP FLANGE 6000 P.S.I.
6000 P.S.I. نصف كوع فلانج ٤٥° طويل قليلاً قطعة واحدة

PART REF.	السعر	العدد	فتحة الخرطوم		قياس الفلانجة	القياسات مم				ملاحظات
	PRICE	QTY	HOSE BORE	FLANGE	DIMENSIONS mm	B	D	A	E	REM.
			DN	INCH	INCH					
HT23645- 10 – 12L.L			16	5/8"	3/4"	15	41.3	72.5	32	
- 12 - 12L.L			19	3/4"	3/4"	15	41.3	113	40	
- 16 - 16L.L			25	1"	1"	20	47.5	113.5	43	
- 20 - 20L.L			31	1. 1/4"	1. 1/4"	25	54	133.5	50	

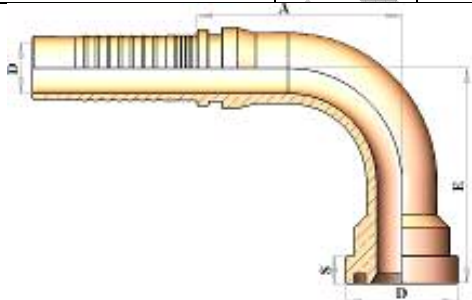

HT23790L.L 90° LITTLE LONG DROP FLANGE 6000 P.S.I.
6000 P.S.I. كوع فلانج ٩٠° طويل قليلاً قطعة واحدة

PART REF.	السعر	العدد	فتحة الخرطوم		قياس الفلانجة	القياسات مم				ملاحظات
	PRICE	QTY	HOSE BORE	FLANGE	DIMENSIONS mm	B	D	A	E	REM.
			DN	INCH	INCH					
HT23645- 10 – 12L.L			16	5/8"	3/4"	15	41.3	61.5	60.5	
- 12 - 12L.L			19	3/4"	3/4"	15	41.3	93	75	
- 16 - 16L.L			25	1"	1"	20	47.5	90	90	
- 20 - 20L.L			31	1. 1/4"	1. 1/4"	25	54	115	110	

HYDRO – TEC

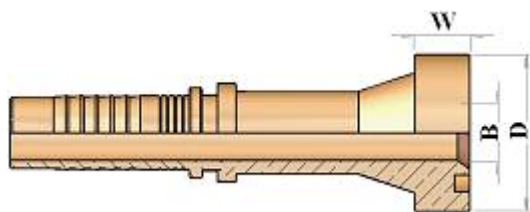

SUPER CAT

HT23911 STRAIGHT SAE FLANGE 9000 P.S.I.

9000 P.S.I. مستقيم فلانج قطعة واحدة

PART REF.	السعر	العدد	فتحة الخرطوم		قياس الفلانجة	القياسات مم			ملاحظات
	PRICE	QTY	HOSE BORE		FLANGE	DIMENSIONS mm			REM.
			DN	INCH	INCH	B	D	W	
HT23911- 12 -12			19	3/4"	3/4"	15	41.3	14.5	
- 12 - 16			20	3/4"	1"	20	47.5	14.5	
- 16 - 16			25	1"	1"	20	47.5	14.5	
- 16 - 20			25	1"	1. 1/4"	25	54	14.5	
- 20 - 20			31	1. 1/4"	1. 1/4"	25	54	14.5	
- 20 - 24			31	1. 1/4"	1. 1/2"	30	63.5	14.5	
- 24 - 24			38	1. 1/2"	1. 1/2"	30	63.5	14.5	

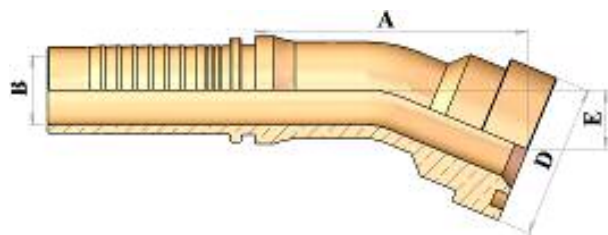

HT23922 22.5° FLANGE 9000 P.S.I.

9000 P.S.I. فلانج قطعة واحدة 22.5°

PART REF.	السعر	العدد	فتحة الخرطوم		قياس الفلانجة	القياسات مم				ملاحظات
	PRICE	QTY	HOSE BORE		FLANGE	DIMENSIONS mm				REM.
			DN	INCH	INCH	B	D	A	E	
HT23922- 12 – 12T			19	3/4"	3/4"	16	41.5	94.5	14.5	
- 12 – 16T			19	3/4"	1"	20	47.7	102	16.5	
- 16 – 16T			25	1"	1"	20	47.7	111	16.5	
- 16 – 20T			25	1"	1. 1/4"	26	54	115.5	19	
- 20 – 20T			31	1. 1/4"	1. 1/4"	26	54	122	18	
- 20 – 24T			31	1. 1/4"	1. 1/2"	32	63.6	139	23	
- 24 – 24T			38	1. 1/2"	1. 1/2"	32	63.6	138	20	

HYDRO – TEC

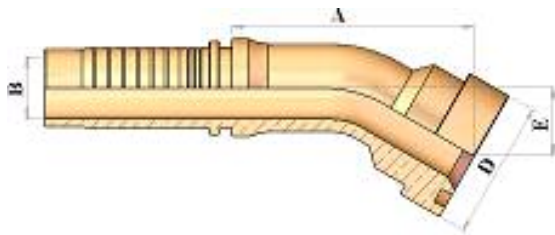

HT23930 30° FLANGE 9000 P.S.I.
فلانج قطعة واحدة ٣٠° 9000 P.S.I.

PART REF.	السعر	العدد	فتحة الخرطوم		قياس الفلانجة	القياسات مم				ملاحظات
	PRICE	QTY	HOSE BORE		FLANGE	DIMENSIONS mm				REM.
			DN	INCH	INCH	B	D	A	E	
HT23930- 12 – 12T			19	3/4"	3/4"	16	41.5	92	20	
- 12 – 16T			19	3/4"	1"	20	47.7	99.5	22.5	
- 16 – 16T			25	1"	1"	20	47.7	108.5	23	
- 16 – 20T			25	1"	1. 1/4"	20	54	112.5	26	
- 20 – 20T			31	1. 1/4"	1. 1/4"	26	54	119	25	
- 20 – 24T			31	1. 1/4"	1. 1/2"	26	63.6	135.5	32	
- 24 – 24T			38	1. 1/2"	1. 1/2"	32	63.6	135	28	
- 24 – 32T			38	1. 1/2"	2"	42	79.5	151.5	36	
- 32 – 32T			51	2"	2"	42	79.5	171.5	37.5	

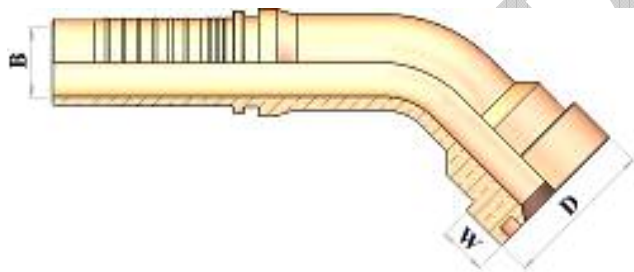

SUPER CAT
HT23945 45° FLANGE 9000 P.S.I.
نصف كوع ٤٥° فلانج قطعة واحدة 9000 P.S.I.

PART REF.	السعر	العدد	فتحة الخرطوم		قياس الفلانجة	القياسات مم			ملاحظات
	PRICE	QTY	HOSE BORE		FLANGE	DIMENSIONS mm			REM.
			DN	INCH	INCH	B	D	W	
HT23945- 12 -12			19	3/4"	3/4"	15	41.3	14.5	
- 12 - 16			20	3/4"	1"	20	47.5	14.5	
- 16 - 16			25	1"	1"	20	47.5	14.5	
- 16 - 20			25	1"	1. 1/4"	25	54	14.5	
- 20 - 20			31	1. 1/4"	1. 1/4"	25	54	14.5	
- 20 - 24			31	1. 1/4"	1. 1/2"	30	63.5	14.5	
- 24 - 24			38	1. 1/2"	1. 1/2"	30	63.5	14.5	

HYDRO – TEC

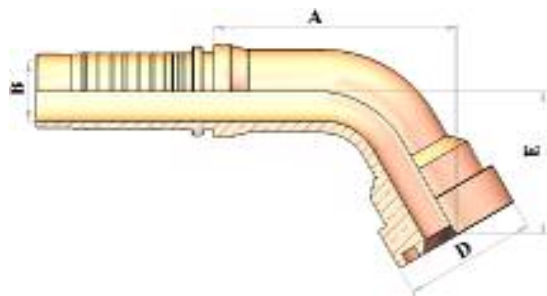

HT23960 60° FLANGE 9000 P.S.I.
9000 P.S.I. °٦٠ فلانج قطعة واحدة

PART REF.	السعر	العدد	فتحة الخرطوم		قياس الفلانة	القياسات مم				ملاحظات
	PRICE	QTY	HOSE BORE	FLANGE	DIMENSIONS mm				REM.	
			DN	INCH	INCH	B	D	A	E	
HT23960- 12 – 12T			19	3/4"	3/4"	16	41.5	101.5	44	
- 12 – 16T			19	3/4"	1"	20	47.7	106.5	48	
- 16 – 16T			25	1"	1"	20	47.7	122	51	
- 16 – 16055			25	1"	1"	20	47.7	117.5	55	
- 16 – 20T			25	1"	1. 1/4"	20	54	122.5	55	
- 20 – 20T			31	1. 1/4"	1. 1/4"	26	54	135.5	56	
- 20 – 24T			31	1. 1/4"	1. 1/2"	26	63.6	149	69	
- 24 – 24T			38	1. 1/2"	1. 1/2"	32	63.6	154.5	63	
- 32 – 32T			51	2"	2"	42	79.5	202	86.5	
- 32 – 32150			51	2"	2"	42	79.5	196.5	150	

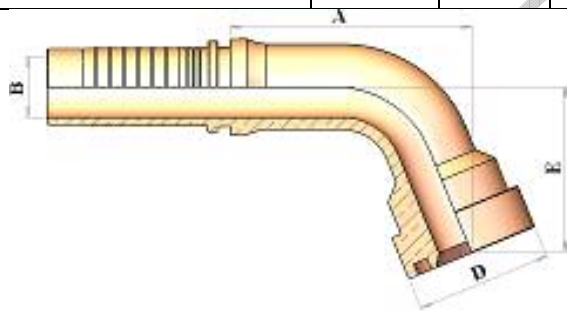

HT23967 67.5° FLANGE 9000 P.S.I.
9000 P.S.I. °٦٧.٥ فلانج قطعة واحدة

PART REF.	السعر	العدد	فتحة الخرطوم		قياس الفلانة	القياسات مم				ملاحظات
	PRICE	QTY	HOSE BORE	FLANGE	DIMENSIONS mm				REM.	
			DN	INCH	INCH	B	D	A	E	
HT23967- 12 – 12T			19	3/4"	3/4"	16	41.5	95.5	49.5	
- 12 – 16T			19	3/4"	1"	20	47.7	100	54	
- 16 – 16T			25	1"	1"	20	47.7	115	58	
- 16 – 20T			25	1"	1. 1/4"	20	54	115	62	
- 20 – 20T			31	1. 1/4"	1. 1/4"	26	54	128	64	
- 20 – 24T			31	1. 1/4"	1. 1/2"	26	63.6	139.5	78	
- 24 – 24T			38	1. 1/2"	1. 1/2"	32	63.6	146	72	

HYDRO – TEC

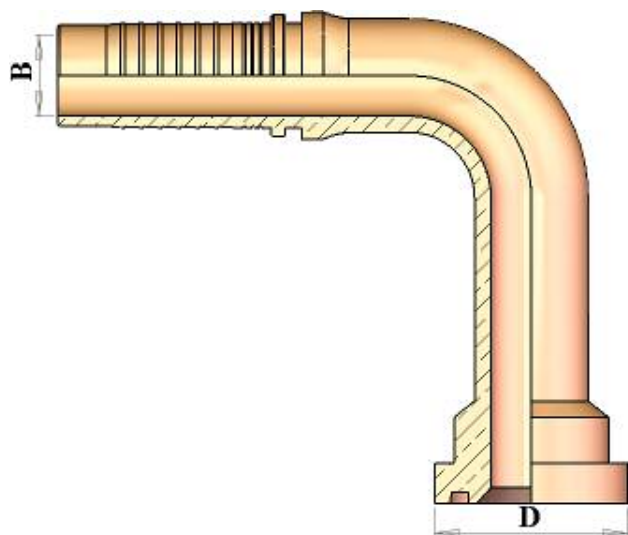

SUPER CAT
HT23990L 90° LONG DROP FLANGE 9000 P.S.I.
كوع فلانج ٩٠° طويل قطعة واحدة 9000 P.S.I.

PART REF.	السعر	العدد	فتحة الخرطوم		قياس الفلانجة	القياسات مم			ملاحظات
	PRICE	QTY	DN	INCH	FLANGE INCH	B	D	W	REM.
HT23990- 12 -12L			19	3/4"	3/4"	15	41.3	14.5	
- 12 – 16L			20	3/4"	1"	20	47.5	14.5	
- 16 – 16L132			25	1"	1"	20	47.5	14.5	
- 16 – 16L150			25	1"	1"	20	47.5	14.5	
- 16 – 20L150			25	1"	1. 1/4"	25	54	14.5	
- 20 – 20L092			31	1. 1/4"	1. 1/4"	25	54	14.5	
- 20 – 20L150			31	1. 1/4"	1. 1/4"	25	54	14.5	
- 20 – 24L135			31	1. 1/4"	1. 1/2"	30	63.5	14.5	
- 24 – 24L106			38	1. 1/2"	1. 1/2"	30	63.5	14.5	
- 24 – 24L140			38	1. 1/2"	1. 1/2"	30	63.5	14.5	

HYDRO – TEC

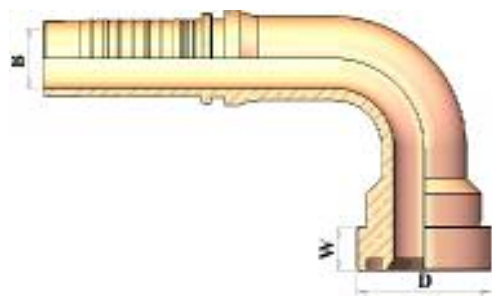

SUPER CAT

HT23990 90° FLANGE 9000 P.S.I.

كوع فلانج ٩٠° قطعة واحدة 9000 P.S.I.

PART REF.	السعر	العدد	فتحة الخرطوم		قياس الفلانجة	القياسات مم			ملاحظات
	PRICE	QTY	DN	INCH	FLANGE INCH	B	D	W	REM.
HT23990- 12 -12			19	3/4"	3/4"	15	41.3	14.5	
- 12 - 16			20	3/4"	1"	20	47.5	14.5	
- 16 - 16			25	1"	1"	20	47.5	14.5	
- 16 - 20			25	1"	1. 1/4"	25	54	14.5	
- 20 - 20			31	1. 1/4"	1. 1/4"	25	54	14.5	
- 20 - 24			31	1. 1/4"	1. 1/2"	30	63.5	14.5	
- 24 - 24			38	1. 1/2"	1. 1/2"	30	63.5	14.5	



HT83308 SPLIT FLANGE CLAMPS 3000 P.S.I.

قمرية فلانج 3000 P.S.I.

PART REF.	السعر	العدد	قياس الفلنجة		ملاحظات
	PRICE	QTY	DN	INCH	REM.
HT83308- 08			12	1/2"	
- 12			19	3/4"	
- 16			25	1"	
- 20			31	1. 1/4"	
- 24			38	1. 1/2"	
- 32			51	2"	
- 40			63	2. 1/2"	

HYDRO – TEC

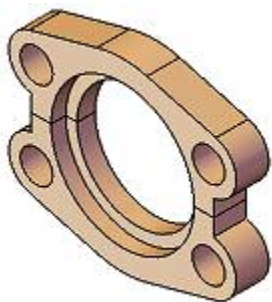

HT83608 SPLIT FLANGE CLAMPS 6000 P.S.I. قمرية فلانج 6000 P.S.I.

PART REF.	السعر	العدد	قياس الفلنجة		ملاحظات
	PRICE	QTY	FLANGE		REM.
			DN	INCH	
HT83608- 08			12	1/2"	
- 12			19	3/4"	
- 16			25	1"	
- 20			31	1. 1/4"	
- 24			38	1. 1/2"	
- 32			51	2"	

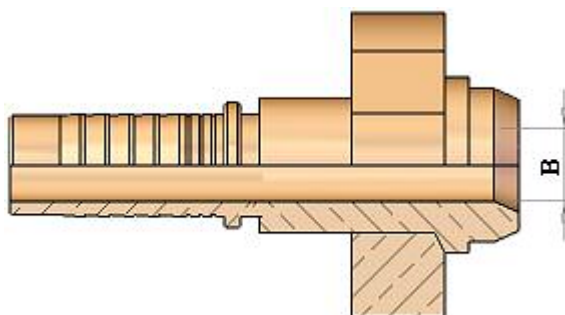

HT14513 POCLAIN MALE FLANGE ذكر فلانج (طبشة) بوكلين

PART REF.	السعر	العدد	فتحة الخرطوم		قياس الفلانجة	القياسات مم			ملاحظات
	PRICE	QTY	HOSE BORE		FLANGE	DIMENSIONS mm			REM.
			DN	INCH	INCH	B	X	CON	
HT14513- 08 -08			12	1/2"	1/2"	9.5	44.4	17	
- 10 - 10			16	5/8"	5/8"	12	44.4	21.3	
- 12 - 12			19	3/4"	3/4"	14	56.1	27	
- 16 - 16			25	1"	1"	20	63.6	22.5	
- 20 - 20			31	1. 1/4"	1. 1/4"	26.1	73.9	42	

HYDRO – TEC

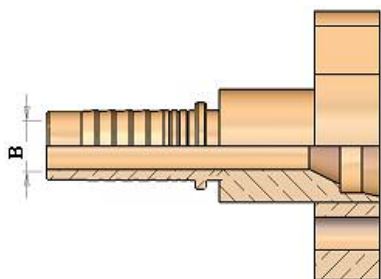

HT24513 POCLAIN FEMALE FLANGE

أنثى فلانج (طبشة) بوكلين

PART REF.	السعر	العدد	فتحة الخرطوم		قياس الفلانجة	القياسات مم			ملاحظات
	PRICE	QTY	HOSE BORE	FLANGE	DIMENSIONS mm	REM.			
			DN	INCH	INCH	B	X	CON	
HT24513- 08 -08			12	1/2"	1/2"	9.5	44.4	17	
- 10 - 10			16	5/8"	5/8"	12	44.4	21.3	
- 12 - 12			19	3/4"	3/4"	14	56.1	27	
- 16 - 16			25	1"	1"	20	63.6	22.5	
- 20 - 20			31	1. 1/4"	1. 1/4"	26.1	73.9	42	

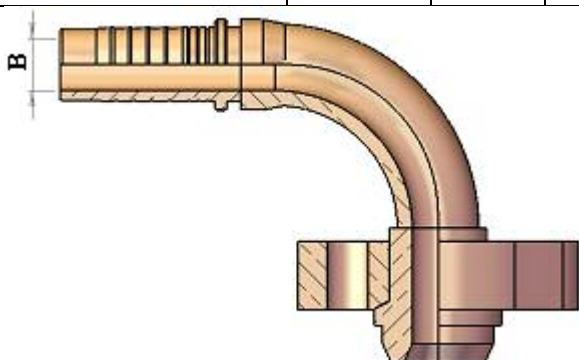

HT24593 90° POCLAIN FEMALE FLANGE

كوع ٩٠° فلانج (طبشة) بوكلين

PART REF.	السعر	العدد	فتحة الخرطوم		قياس الفلانجة	القياسات مم			ملاحظات
	PRICE	QTY	HOSE BORE	FLANGE	DIMENSIONS mm	REM.			
			DN	INCH	INCH	B	X	CON	
HT24593- 08 -08			12	1/2"	1/2"	9.5	44.4	17	
- 10 - 10			16	5/8"	5/8"	12	44.4	21.3	
- 12 - 12			19	3/4"	3/4"	14	56.1	27	
- 16 - 16			25	1"	1"	20	63.6	22.5	
- 20 - 20			31	1. 1/4"	1. 1/4"	26.1	73.9	42	

HYDRO – TEC

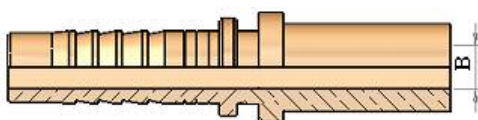

HT22010 METRIC STANDPIPE STRAIGHT DIN 2353

مستقيم متري رأس ماسورة

PART REF.	السعر	العدد	فتحة الخرطوم		القياسات مم		ملاحظات
	PRICE	QTY	DN	D	PIPE	B	REM.
HT22010- 03 - 04			5	3/16"	4	2	
- 03 - 06			5	3/16"	6	3	
- 03 - 08			5	3/16"	8	3	
- 04 - 06			6	1/4"	6	4	
- 04 - 08			6	1/4"	8	4	
- 04 - 10			6	1/4"	10	4	
- 04 - 12			6	1/4"	12	7	
- 05 - 10			8	5/16"	10	7	
- 05 - 12			8	5/16"	12	7	
- 06 - 10			10	3/8"	10	7	
- 06 - 12			10	3/8"	12	8	
- 06 - 14			10	3/8"	14	8	
- 06 - 15			10	3/8"	15	10.5	
- 08 - 12			12	1/2"	12	8	
- 08 - 14			12	1/2"	14	9.3	
- 08 - 15			12	1/2"	15	10.5	
- 08 - 16			12	1/2"	16	10.5	
- 08 - 18			12	1/2"	18	12.5	
- 10 - 18			16	5/8"	18	12.5	
- 10 - 20			16	5/8"	20	12.5	
- 10 - 22			16	5/8"	22	15	
- 12 - 18			19	3/4"	18	15	
- 12 - 20			19	3/4"	20	15	
- 12 - 22			19	3/4"	22	15	
- 12 - 25			19	3/4"	25	15	
- 16 - 25			25	1"	25	20.5	
- 16 - 28			25	1"	28	20.5	
- 16 - 30			25	1"	30	20.5	
- 16 - 38			25	1"	38	26	
- 20 - 30			31	1. 1/4"	30	20.5	
- 20 - 35			31	1. 1/4"	35	26	
- 20 - 38			31	1. 1/4"	38	26	
- 24 - 38			38	1. 1/2"	38	26	
- 24 - 42			38	1. 1/2"	42	32	

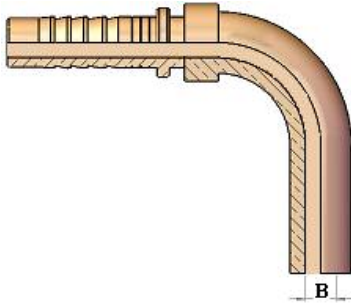

HT22090 90° METRIC STANDPIPE DIN 2353

كوع ٩٠ متري رأس ماسورة

PART REF.	السعر	العدد	فتحة الخرطوم		القياسات مم		ملاحظات
	PRICE	QTY	DN	D	PIPE	B	REM.
HT22090- 03 - 06			5	3/16"	6	3	
- 04 - 06			6	1/4"	6	4	
- 04 - 08			6	1/4"	8	4	
- 04 - 10			6	1/4"	10	4	
- 04 - 12			6	1/4"	12	7	
- 05 - 10			8	5/16"	10	7	
- 05 - 12			8	5/16"	12	7	
- 06 - 10			10	3/8"	10	7	
- 06 - 12			10	3/8"	12	8	
- 06 - 14			10	3/8"	14	8	
- 08 - 14			12	1/2"	14	9.3	
- 08 - 15			12	1/2"	15	10.5	
- 08 - 16			12	1/2"	16	10.5	
- 08 - 18			12	1/2"	18	12.5	
- 10 - 18			16	5/8"	18	12.5	
- 10 - 20			16	5/8"	20	12.5	
- 12 - 20			19	3/4"	20	15	
- 12 - 22			19	3/4"	22	15	
- 12 - 25			19	3/4"	25	15	
- 16 - 25			25	1"	25	20.5	
- 16 - 28			25	1"	28	20.5	
- 16 - 38			25	1"	38	26	
- 20 - 35			31	1. 1/4"	35	26	

HYDRO – TEC

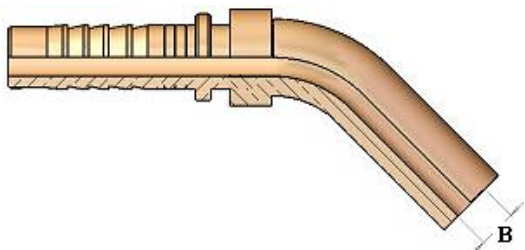

HT22040 45° METRIC STANDPIPE DIN 2353

نصف كوع ٤٥° متري رأس ماسورة

PART REF.	السعر	العدد	فتحة الخرطوم		القياسات مم		ملاحظات
	PRICE	QTY	DN	D	PIPE	B	REM.
HT22040- 04 - 06			6	1/4"	6	4	
- 04 - 08			6	1/4"	8	4	
- 04 - 10			6	1/4"	10	4	
- 05 - 10			8	5/16"	10	7	
- 06 - 10			10	3/8"	10	7	
- 06 - 12			10	3/8"	12	8	
- 06 - 14			10	3/8"	14	8	
- 08 - 15			12	1/2"	15	10.5	
- 08 - 16			12	1/2"	16	10.5	
- 10 - 18			16	5/8"	18	12.5	
- 10 - 20			16	5/8"	20	12.5	
- 12 - 22			19	3/4"	22	15	
- 12 - 25			19	3/4"	25	15	
- 16 - 25			25	1"	25	20.5	
- 16 - 28			25	1"	28	20.5	

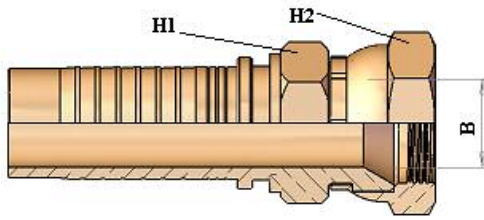

HT23811 JAPANESE GAS JIS (TYPE T)

متحرك ياباني سن إنكليزي (تويوتا)

PART REF.	السعر	العدد	فتحة الخرطوم		شرار - سن	القياسات مم			ملاحظات
	PRICE	QTY	DN	INCH	T	B	H1	H2	REM.
HT23811-04-04			6	1/4"	1/4" - 19	4	14	19	
- 06 - 06			10	3/8"	3/8" - 19	7	17	22	
- 08 - 08			12	1/2"	1/2" - 14	9.6	19	27	
- 12 - 12			19	3/4"	3/4" - 14	15	27	32	
- 16 - 16			25	1"	1" - 11	20	32	41	
- 20 - 20			31	1. 1/4"	1. 1/4"-11	26	41	50	

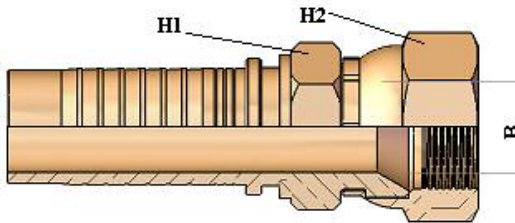

HT24011 JAPANESE METRIC FEMALE JIS (TYPE K)

متحرك ياباني سن متري (كوماتسو)

PART REF.	السعر	العدد	فتحة الخرطوم		شرار - سن	القياسات مم			ملاحظات
	PRICE	QTY	DN	INCH	T	B	H1	H2	REM.
HT24011- 04 -14			6	1/4"	M 14x1.5	4	14	19	
- 05 - 16			8	5/16"	M 16x1.5	5	14	22	
- 06 - 16			10	3/8"	M 16x1.5	6	15	22	
- 06 - 18			10	3/8"	M 18x1.5	7	17	24	
- 08 - 22			12	1/2"	M 22x1.5	9.6	19	27	
- 10 - 24			16	5/8"	M 24x1.5	12	24	32	
- 12 - 30			19	3/4"	M 30x1.5	15	30	36	
- 16 - 33			25	1"	M 33x1.5	20	32	41	
- 20 - 36			31	1. 1/4"	M 36x1.5	23	41	46	
- 24 - 42			38	1. 1/2"	M 42x1.5	29	46	55	

HYDRO – TEC

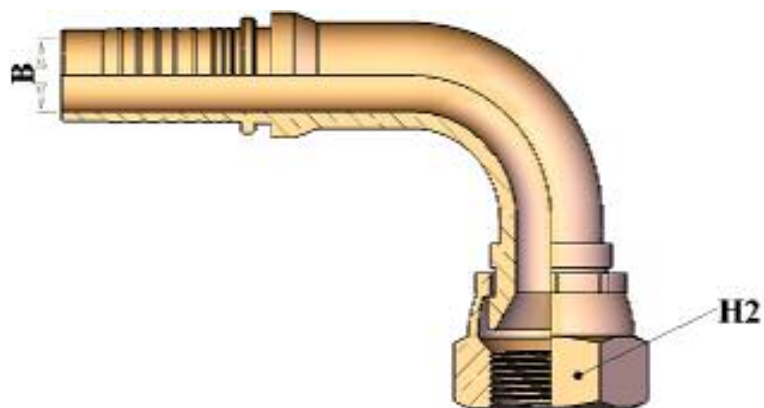

HT24091 90° JAPANESE METRIC JIS (TYPE K)

كوع ياباني سن متري (كوماتسو)

PART REF.	السعر	العدد	فتحة الخرطوم		شرار- سن	القياسات مم			ملاحظات
	PRICE	QTY	HOSE BORE		THREAD	DIMENSIONS mm			REM.
			DN	INCH	T2	B	H1	H2	
HT24091- 04 -14			6	1/4"	M 14x1.5	4	14	19	
- 05 - 16			8	5/16"	M 16x1.5	5	17	22	
- 06 - 16			10	3/8"	M 16x1.5	6	14	22	
- 06 - 18			10	3/8"	M 18x1.5	7	17	24	
- 08 - 22			12	1/2"	M 22x1.5	9.6	19	27	
- 10 - 24			16	5/8"	M 24x1.5	12	24	32	
- 12 - 30			19	3/4"	M 30x1.5	15	30	36	
- 16 - 33			25	1"	M 33x1.5	20	32	41	
- 20 - 36			31	1. 1/4"	M 36x1.5	23	41	46	
- 24 - 42			38	1. 1/2"	M 42x1.5	29	46	55	

HYDRO – TEC

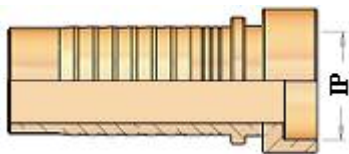

HT00IP00 WELDING T-CONNECTOR

PART REF.	السعر	العدد	فتحة الخرطوم		القياسات	ملاحظات
	PRICE	QTY	DN	INCH	DIMENSIONS mm	
HT03IP05			5	3/16"	5	
HT03IP06			5	3/16"	6	
HT04IP06			6	1/4"	6	
HT04IP08			6	1/4"	8	
HT05IP08			8	5/16"	8	
HT05IP10			8	5/16"	10	
HT06IP10			10	3/8"	10	
HT06IP12			10	3/8"	12	
HT06IP14			10	3/8"	14	
HT08IP15			12	1/2"	15	
HT08IP16			12	1/2"	16	
HT10IP18			16	5/8"	18	
HT12IP22			19	3/4"	22	
HT16IP28			25	1"	28	
HT16IP30			25	1"	30	
HT20IP35			31	1. 1/4"	35	
HT24IP40			38	1. 1/2"	40	
HT32IP50			51	2"	50	

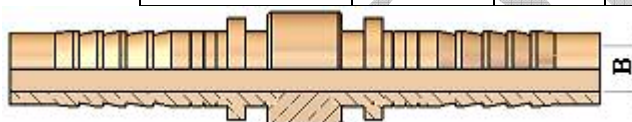

HT10050 HOSE CONNECTOR

وصلة خرطوم

PART REF.	السعر	العدد	فتحة الخرطوم		القياسات	ملاحظات
	PRICE	QTY	DN	INCH	DIMENSIONS mm	
HT10050- 04 - 04			6	1/4"	4	
- 05 - 05			8	5/16"	5	
- 06 - 06			10	3/8"	6.5	
- 08 - 08			12	1/2"	9.5	
- 10 - 10			16	5/8"	12	
- 12 - 12			19	3/4"	15	
- 16 - 16			25	1"	20	
- 20 - 20			31	1. 1/4"	25	
- 24 - 24			38	1. 1/2"	30	
-32 - 32			51	2"	42	



HYDRO-TEC

ADAPTORS

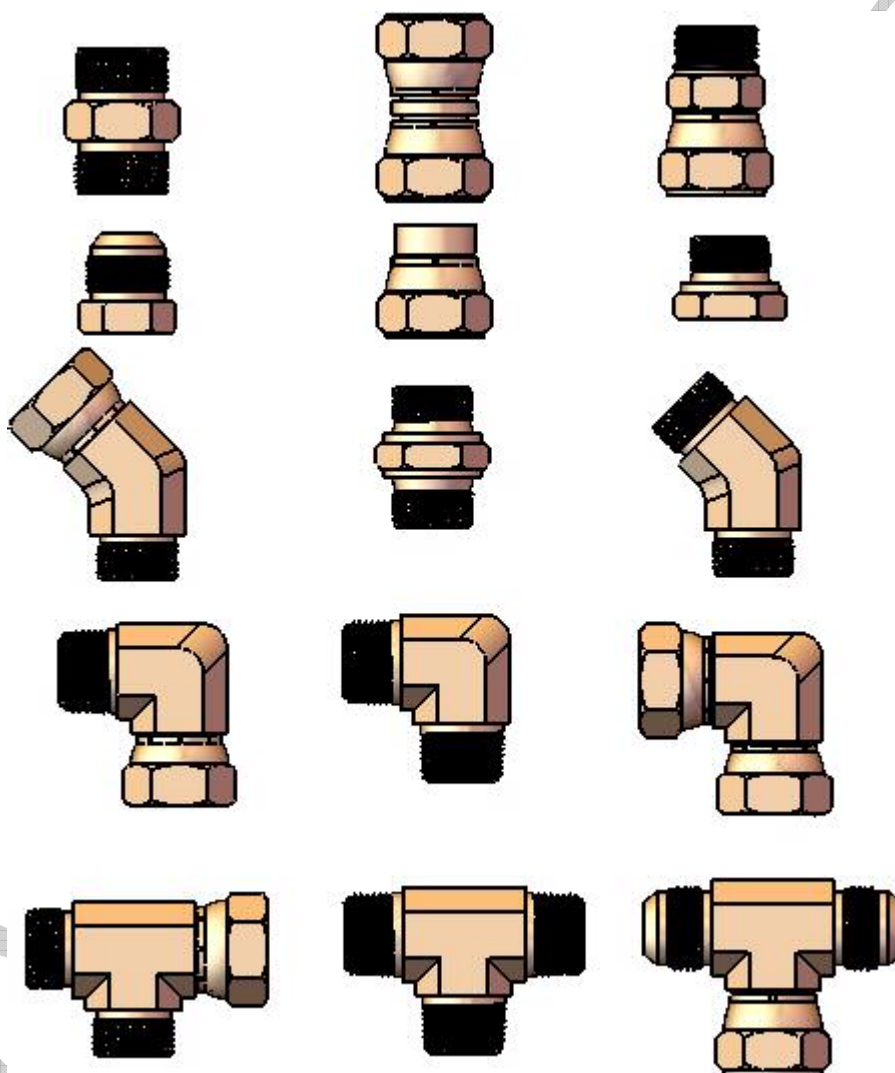

ADAPTOR INDEX

PAGE	PART REF.	STANDARD TYPE	النوع
073		ADAPTOR NUMBERIG SYSTEM	نظام ترقيم الراكورات
075	HT502525	STRAIGHT ADAPTOR JIC MALE	نبيل مستقيم سن أمريكي ذكر
076	HT502523	STRAIGHT BULKHEAD ADAPTOR JIC MALE	نبيل مستقيم سن أمريكي ذكر كنترول
076	HT523025	STRAIGHT ADAPTOR SEA O'RING MALE / JIC FEMALE	نبيل ذكر سن أورنج / متحرك سن أمريكي
077	HT522525	STRAIGHT ADAPTOR JIC MALE / JIC FEMALE (C/B NUT)	نبيل ذكر / أنثى سن أمريكي
078	HT502505	STRIGHT ADAPTOR JIC MALE / BSP MALE	نبيل ذكر سن أمريكي / ذكر سن إنكليزي BSP
079	HT502507	STRIGHT ADAPTOR JIC MALE / BSPT MALE	نبيل ذكر سن أمريكي / ذكر سن إنكليزي BSPT
080	HT502530	STRAIGHT ADAPTOR JIC MALE / SEA O'RING MALE	نبيل ذكر سن أمريكي / ذكر سن أورنج
081	HT520525	STRIGHT ADAPTOR BSP MALE / JIC FEMALE	نبيل متحرك سن أمريكي / ذكر سن إنكليزي BSP
082	HT520725	STRIGHT ADAPTOR BSPT MALE / JIC FEMALE	نبيل متحرك سن أمريكي / ذكر سن إنكليزي BSPT
083	HT532523	45 ELBOW BULKHEAD ADAPTOR JIC MALE 74 CONE	نبيل نصف كوع سن أمريكي ذكر مع حاجز
083	HT552525	45 ELBOW ADAPTOR JIC MALE / JIC FEMALE	نبيل نصف كوع ذكر سن أمريكي / متحرك سن أمريكي
084	HT532507	45 ELBOW ADAPTOR JIC MALE / BSPT MALE	نبيل نصف كوع ذكر سن أمريكي / ذكر سن BSPT
085	HT562525	90 ELBOW ADAPTOR JIC MALE 74 CONE	نبيل كوع سن أمريكي ذكر
085	HT582525	90° ELBOW ADAPTOR JIC MALE 74° CONE	نبيل كوع ذكر سن أمريكي / متحرك سن أمريكي
086	HT562507	90 ELBOW ADAPTOR JIC MALE / BSPT MALE	نبيل كوع ذكر سن أمريكي / ذكر سن إنكليزي BSPT
087	HT702507	BRANCH TEE ADAPTOR JIC MALE BSPT MALE 74° CONE	مثلث طرفين سن أمريكي ذكر / وسط BSPT
087	HT702525	UNION TEE ADAPTOR JIC MALE 74° CONE	مثلث سن أمريكي ذكر
088	HT712525	UNION TEE ADAPTOR JIC MALE / JIC FEMALE 74° CONE	مثلث سن أمريكي طرفين ذكر وسط متحرك
088	HT722525	RUN TEE ADAPTOR JIC MALE / JIC FEMALE 74° CONE	مثلث سن أمريكي طرفين ذكر طرف متحرك
089	HT500505	STRAIGHT ADAPTOR BSP MALE / BSP MALE	نبيل ذكر / ذكر سن إنكليزي
090	HT500404	STRAIGHT ADAPTOR MALE / BSP MALE	نبيل ذكر / ذكر سن إنكليزي مسدس ص
091	HT500407	STRAIGHT ADAPTOR MALE BSP / MALE BEST	نبيل ذكر سن BSPT / ذكر سن BSP مسدس صغير
092	HT500707	STRAIGHT ADAPTOR BEST MALE / BEST MALE	نبيل ذكر سن BSPT طرفين
093	HT520505	STRAIGHT ADAPTOR BSP MALE / BSP FEMALE	نبيل ذكر / أنثى سن إنكليزي
094	HT520405	STRAIGHT ADAPTOR BSP MALE / BSP FEMALE	نبيل ذكر مسدس صغير / أنثى سن إنكليزي
095	HT510505	STRAIGHT ADAPTOR BSP FEMALE / BSP FEMALE	نبيل أنثى / أنثى سن إنكليزي
095	HT530404	45° ELBOW ADAPTOR BSP MALE / BSP MALE	نبيل نصف كوع ذكر سن إنكليزي / ذكر سن إنكليزي مسدس صغير



HYDRO – TEC

PAGE	PART REF.	STANDARD TYPE	النوع
096	HT530407	45° ELBOW ADAPTOR BSP MALE / BSPT MALE	نبيل نصف كوع ذكر BSP مسدس صغير / ذكر BSPT
096	HT550405	45° ELBOW ADAPTOR BSP MALE / BSP FEMALE	نبيل نصف كوع ذكر سن إنكليزي مسدس صغير / متحرك سن إنكليزي
097	HT560404	45° ELBOW ADAPTOR BSP MALE / BSP MALE	نبيل كوع ذكر سن إنكليزي / ذكر سن إنكليزي مسدس صغير
097	HT580405	90° ELBOW ADAPTOR BSP MALE / BSP FEMALE (C/B NUT)	نبيل كوع ذكر سن إنكليزي / أنثى سن إنكليزي
098	HT560407	90° ELBOW ADAPTOR BSP MALE / BSPT MALE	نبيل كوع ذكر BSP مسدس صغير / ذكر BSPT
098	HT580705	90° ELBOW ADAPTOR BSPT MALE / BSP FEMALE (C/B NUT)	نبيل كوع ذكر BSPT / أنثى BSP
099	HT560707	90° ELBOW ADAPTOR BSPT MALE / BSPT MALE	نبيل كوع ذكر BSPT / ذكر BSPT
099	HT570505	90° ELBOW ADAPTOR FEMALE / BSP FEMALE	نبيل كوع أنثى BSP / أنثى BSP
100	HT700404	UNION TEE BSP MALE	مثلث 3 أطراف BSP
100	HT730505	UNION TEE BSP FEMALE	مثلث 3 أطراف متحرك BSP
101	HT710405	BRANCH TEE BSP MALE / BSP FEMALE	مثلث BSP طرفين ذكر / وسط متحرك
101	HT720405	RUN TEE BSP MALE / BSP FEMALE	مثلث طرف ذكر BSP / وسط ذكر BSP / طرف متحرك BSP
102	HT500615	ST ADAPTOR BSP FLAT MALE / METRIC MALE	نبيل ذكر متري / ذكر BSP
104	HT500515	ST ADAPTOR BSP O'RING MALE / METRIC MALE	نبيل ذكر متري / ذكر BSP
106	HT500815	STRAIGHT ADAPTOR BSPT MALE/ METRIC MALE	نبيل ذكر متري / ذكر BSPT
108	HT500715	STRAIGHT ADAPTOR BSPT MALE/ METRIC MALE	نبيل ذكر متري / ذكر BSPT
110	HT500524	STRAIGHT ADAPTOR BSP MALE / ORFS MALE	نبيل ذكر BSP / ذكر ORFS
110	HT500724	STRAIGHT ADAPTOR BSPT MALE / ORFS MALE	نبيل ذكر BSPT / ذكر ORFS
111	HT502424	STRAIGHT ADAPTOR ORFS MALE	نبيل ذكر ORFS / ذكر ORFS
112	HT501515	STRAIGHT ADAPTOR METRIC MALE LIGHT	نبيل ذكر متري خفيف
113	HT501616	STRAIGHT ADAPTOR METRIC MALE HEAVY	نبيل ذكر متري ثقيل
114	HT501517	STRAIGHT ADAPTOR METRIC MALE L.T/O'RING	نبيل ذكر متري خفيف طرف تثبيت
115	HT501517	STRAIGHT ADAPTOR METRIC MALE H.T/O'RING	نبيل ذكر متري خفيف طرف تثبيت
116	HT501512	STRAIGHT BULKHEAD ADAPTOR METRIC MALE	نبيل متري ذكر / ذكر مع عذقة كترول
117		METRIC LOCK NUT	عذقة كترول متري
118	HT571515	90 ELBOW ADAPTOR METRIC MALE / FEMALE	نبيل كوع ذكرين متري / متحرك متري
118	HT581515	90° ELBOW ADAPTOR METRIC MALE	نبيل كوع ذكرين متري
119	HT701515	UNION TEE ADAPTOR METRIC MALE	مثلث سن متري ذكر
119	HT711515	UNION TEE ADAPTOR METRIC MALE / FEMALE	مثلث متري طرفين ذكر وسط متحرك
120	HT721515	RUN TEE ADAPTOR METRIC MALE / METRIC FEMALE	مثلث سن متري طرفين ذكر مع طرف متحرك
121	HT402500	JIC MALE PLUG	سدة ذكر سن أمريكي
121	HT412500	FEMALE PLUG JIC	سدة متحركة سن أمريكي
122	HT400500	MALE PLUG BSP	سدة ذكر سن إنكليزي
122	HT400700	BSPT PLUG	سدة ذكر سن BSPT
123	HT410500	FEMALE PLUG BSP	سدة متحركة سن إنكليزي



HYDRO – TEC

PAGE	PART REF.	STANDARD TYPE	النوع
124	HT410505	BSP TRANSITION	تحويله BSP
125	HT410707	NPTF TRANSITION	تحويله NPTF
126	HT410515	IN BSP OUT METRIC TRANSITION	تحويله داخلي BSP خارجي متري
126	HT411515	METRIC TRANSITION	تحويله متري
127	HT411505	IN METRIC OUT BSP TRANSITION	تحويله داخلي متري خارجي BSP
128	HT-FNB	BSP FIXED NUT	عزقة نافذة BSP
128	HT-FNM	METRIC FIXED NUT	عزقة نافذة متري

VARIOUS INDEX

PAGE	PART REF.	STANDARD TYPE	النوع
129	MF-ST	JIC MF-ST	مستقيم MF سن أمريكي
129	MF-ST	METRIC MF-ST	مستقيم MF سن متري
130	MF-90	JIC MF-90 ⁰	كوع MF سن أمريكي
130	MF-90	METRIC MF-90 ⁰	كوع MF سن متري
131	MF- 45	JIC MF- 45 ⁰	نصف كوع MF سن أمريكي
131	MF-45	METRIC MF-45 ⁰	نصف كوع MF سن متري
132	HT421500	METRIC PIPE RING	كونيك متري
132		AMERICAN BRASS SLEEVE BARREL	حبسة نحاس أمريكي
132		FILLING POLYAMIDE TUBE	حشوه خرطوم بلاستيك
133		BRASS WASHER	رنديلة نحاس
133		ALUMINUM WASHER	رنديلة ألومنيوم
133		INJECTOR PIPE WASHER	رنديلة بخاخ
133		INJECTOR PIPE FILLING	حشوة بوري بخاخ
134		JIC BRAKE PIPE MALE NUT	عزقة فرام ذكر أمريكي
134		METRIC NUT FOR INJECTOR	عزقة بوري بخاخ متري
134		METRIC FLANGED BLANKING PLUG	سدة كارتيل متري
135		JIC BRAKE PIPE FEMALE NUT	عزقة طربوش أمريكي
135	HT-SP	SPRING FOR HOSE	نابض للخرطوم
136	HT20310	BSP BANJO	بانجو لسن إنكليزي
136	HT80210	BSP BOLT	برغي سن إنكليزي
137	HT20910	METRIC BANJO	بانجو متري
137	HT80810	SHORT METRIC BOLT	برغي متري قصير
138	HT80810L	LONG METRIC BOLT	برغي متري طويل
138	HT11410	METRIC AIR MALE	ذكر هواء متري
139	HT21413	METRIC AIR FEMALE	متحرك هواء متري
139	HT20410	AIR BANGO (ONE NOTCH)	بانجو هواء حز واحد
140	HT20430	AIR BANGO (THREE NOTCH)	بانجو هواء ثلاث حوز

ADAPTOR PART NUMBERING SYSTEM نظام ترقيم الراكورات

1 2 3 4 5 6

FIRST DIGIT الرقم الأول

FIRST DIGIT	DESCREPTION	الوصف
4	ONE END	طرف واحد
5	TWO ENDS	طرفين
7	THREE ENDS	مثلث
9	FOUR ENDS	مربع

1 2 3 4 5 6

SECOND DIGIT الرقم الثاني

THE NUMBER STANDT IN THIS POSOTION (FROM 0-9) REFER GENDER AND ENDS في هذا الموضع الترقيم (من ٠ - ٩) حسب الجنس والنهايات

ONE END طرف واحد		
SECOND DIGIT	DESCREPTION	الوصف
0	MALE PLUG	سدة ذكر
1	FEMALE PLUG	سدة أنثى
2	SLEEVE	كونيك
3	NUT	عزقة

TWO ENDS طرفين			
SECOND DIGIT	1 ST END GENDER جنس الطرف ١	2 ST END GENDER جنس الطرف ٢	GEOMETRY الشكل
0	MALE - ذكر	MALE - ذكر	STRIGHT - مستقيم
1	FEMALE - أنثى	FEMALE - أنثى	STRIGHT - مستقيم
2	MALE - ذكر	FEMALE - أنثى	STRIGHT - مستقيم
3	MALE - ذكر	MALE - ذكر	45°
4	FEMALE - أنثى	FEMALE - أنثى	45°
5	MALE - ذكر	FEMALE - أنثى	45°
6	MALE - ذكر	MALE - ذكر	90°
7	FEMALE - أنثى	FEMALE - أنثى	90°
8	MALE - ذكر	FEMALE - أنثى	90°

THREE ENDS مثلث			
SECOND DIGIT	1 ST END GENDER جنس الطرف ١	3 ST END GENDER جنس الوسط	2 ST END GENDER جنس الطرف ٢
0	MALE - ذكر	MALE - ذكر	MALE - ذكر
1	MALE - ذكر	FEMALE - أنثى	MALE - ذكر
2	MALE - ذكر	MALE - ذكر	FEMALE - أنثى
3	FEMALE - أنثى	FEMALE - أنثى	FEMALE - أنثى
4	FEMALE - أنثى	MALE - ذكر	FEMALE - أنثى
5	FEMALE - أنثى	FEMALE - أنثى	MALE - ذكر

HYDRO – TEC



الرقمين الثالث والرابع THIRD & FORTH DIGIT

الرقمين الخامس والسادس FIFTH & SIXTH DIGIT

THE THIRD AND FORTH DIGIT INDICATE THE FIRST END, WHILE THE FIFTH AND SIXTH DIGIT INDICATE THE SECOND END.

يعبر الرقمين ٤-٣ عن النهاية الأولى بينما يعبر الرقمين ٥-٦ عن النهاية الثانية

DIGIT	DESCRIPTION	الوصف
04	BSP THEARD (60 CONE)	سن انكليزي مسدس صغير
05	BSP THEARD (60 CONE) O'RING	سن انكليزي مركز سيلة
06	BSP THEARD (FLAT FACE)	سن انكليزي وجه مسطح
07	BSPT THEARD (60 CONE)	سن انكليزي BSPT
08	BSPT THEARD (FLAT FACE)	سن انكليزي BSPT
12	METRIC THREAD BULKHEAD	سن متري كمنترول
15	METRIC THREAD (24° CONE) L	سن متري كونيك خفيف
16	METRIC THREAD (24° CONE) H	سن متري كونيك ثقيل
17	METRIC THREAD O'RING	سن متري تثبيت
23	JIC THEARD BULKHEAD	سن أمريكي كمنترول
24	ORFS THEARD	سن ORFS
25	JIC THEARD (37° CONE)	سن أمريكي
30	SAE O'RING TYPE	سن أمريكي مركز سيلة
40	JIS (KOMATSU) THEARD	سن كوماتسو

EXAMPLE

مثال

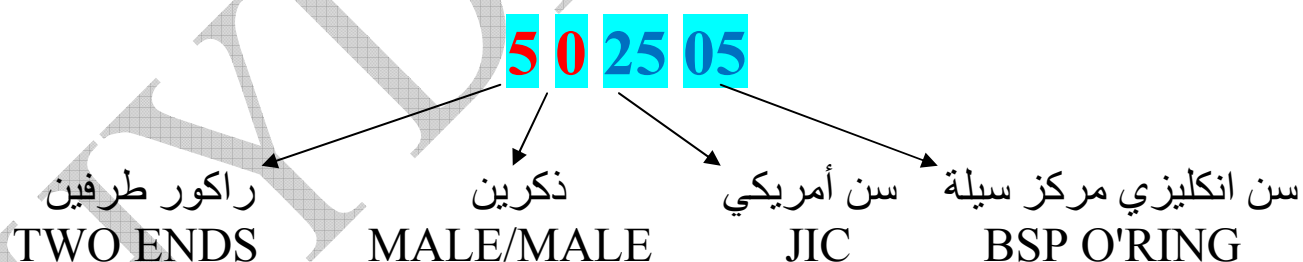

EXAMPLE

مثال

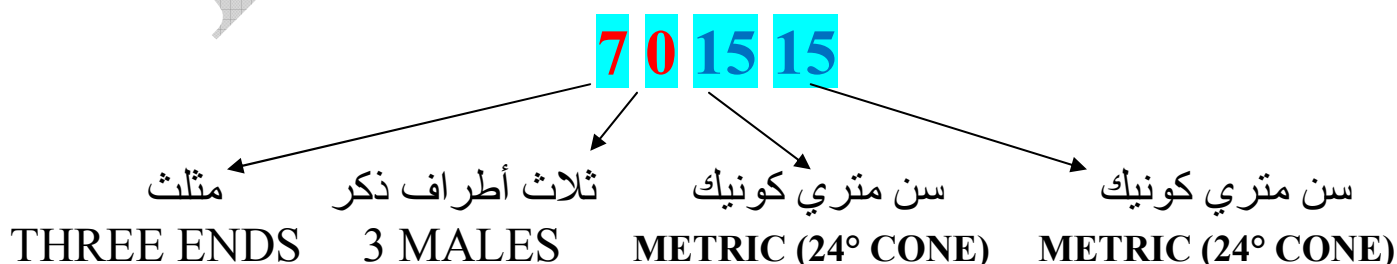

HYDRO – TEC

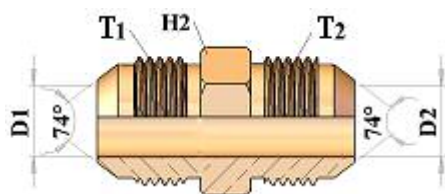

HT502525 STRAIGHT ADAPTOR JIC MALE 74° CONE

نبل مستقيم سن JIC ذكر

النوع	السعر	العدد	الخطوة		القياسات مم			ملاحظات
PART REF.	PRICE	QTY	THREAD		DIMENSIONS mm			REM.
			T1 - JIC	T2 - JIC	D1	D2	H2	
HT502525- 04 - 04			7/16" - 20	7/16" - 20	4	4	12	
- 05 - 04			1/2" - 20	7/16" - 20	5	4	14	
- 05 - 05			1/2" - 20	1/2" - 20	5	5	14	
- 06 - 04			9/16" - 18	7/16" - 20	6.5	4	16	
- 06 - 06			9/16" - 18	9/16" - 18	6.5	6.5	16	
- 08 - 05			3/4" - 16	1/2" - 20	9.5	5	20	
- 08 - 06			3/4" - 16	9/16" - 18	9.5	6.5	20	
- 08 - 08			3/4" - 16	3/4" - 16	9.5	9.5	20	
- 10 - 06			7/8" - 14	9/16" - 18	12	6.5	24	
- 10 - 08			7/8" - 14	3/4" - 16	12	9.5	24	
- 10 - 10			7/8" - 14	7/8" - 14	12	12	24	
- 12 - 08			1 1/16" -12	3/4" - 16	15	9.5	28	
- 12 - 10			1 1/16" -12	7/8" - 14	15	12	28	
- 12 - 12			1 1/16" -12	1 1/16" -12	15	15	28	
- 16 - 10			1 5/16" -12	7/8" - 14	21	12	35	
- 16 - 12			1 5/16" -12	1 1/16" -12	21	15	35	
- 16 - 16			1 5/16" -12	1 5/16" -12	21	21	35	
- 20 - 16			1 5/8" -12	1 5/16" -12	26.5	21	42	
- 20 - 20			1 5/8" -12	1 5/8" -12	26.5	26.5	42	
- 24 - 20			1 7/8" -12	1 5/8" -12	32	26.5	50	
- 24 - 24			1 7/8" -12	1 7/8" -12	32	32	50	
- 32 - 32			2 1/2" -12	2 1/2" -12	44	44	65	

HYDRO – TEC

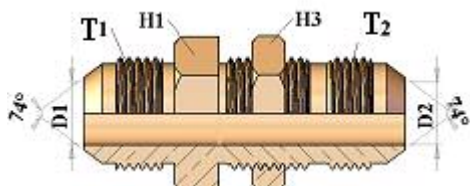

HT502523 STRAIGHT BULKHEAD ADAPTOR JIC MALE 74° CONE

نبيل مستقيم سن JIC طويل مع عزقة كمنترول / ذكر سن JIC

النوع	السعر	العدد	الخطوة		القياسات مم				ملاحظات
PART REF.	PRICE	QTY	THREAD		DIMENSIONS mm				REM.
			T1 - JIC	T2 - JIC	D1	D2	H1	H3	
HT502523- 04 - 04			7/16" - 20	7/16" - 20	4	4	16	16	
- 05 - 05			1/2" - 20	1/2" - 20	5	5	19	16	
- 06 - 06			9/16" - 18	9/16" - 18	6.5	6.5	19	19	
- 08 - 08			3/4" - 16	3/4" - 16	9.5	9.5	24	24	
- 10 - 10			7/8" - 14	7/8" - 14	12	12	27	27	
- 12 - 12			1 1/16" -12	1 1/16" -12	15	15	32	32	
- 16 - 16			1 5/16" -12	1 5/16" -12	21	21	38	38	
- 20 - 20			1 5/8" -12	1 5/8" -12	26.5	26.5	50	50	
- 24 - 24			1 7/8" -12	1 7/8" -12	32	32	55	55	
- 32 - 32			2 1/2" -12	2 1/2" -12	44	44	70	70	

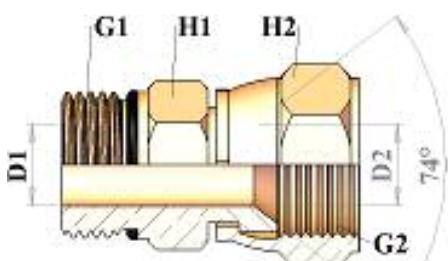

HT523025 STRAIGHT ADAPTOR SEA O'RING MALE / JIC FEMALE

نبيل مستقيم متحرك سن JIC / ذكر سن أورنج JIC

النوع	السعر	العدد	الخطوة		القياسات مم				ملاحظات
PART REF.	PRICE	QTY	THREAD		DIMENSIONS mm				REM.
			T1 - O'RING	T2 - JIC	D1	D2	H1	H2	
HT523025- 04 - 04			7/16" - 20	7/16" - 20	4	4	14	16	
- 05 - 05			1/2" - 20	1/2" - 20	5	5	16	16	
- 06 - 06			9/16" - 18	9/16" - 18	6.5	6.5	16	16	
- 08 - 08			3/4" - 16	3/4" - 16	9.5	9.5	19	19	
- 10 - 10			7/8" - 14	7/8" - 14	12	12	27	27	
- 12 - 12			1 1/16" -12	1 1/16" -12	15	15	32	32	
- 16 - 16			1 5/16" -12	1 5/16" -12	21	21	38	38	
- 20 - 20			1 5/8" -12	1 5/8" -12	26.5	26.5	50	50	
- 24 - 24			1 7/8" -12	1 7/8" -12	32	32	55	55	

HYDRO – TEC

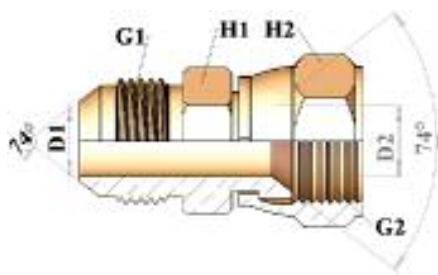

HT522525 STRAIGHT ADAPTOR JIC MALE / JIC FEMALE (C/B NUT)

نبل أنثى سن / JIC ذكر سن

النوع	السعر	العدد	الخطوة		القياسات مم				ملاحظات
PART REF.	PRICE	QTY	THREAD		DIMENSIONS mm				REM.
			T1 - JIC	T2 - JIC	D1	D2	H1	H2	
HT522525-04 - 04			7/16" - 20	7/16" - 20	4	4	12	14	
- 04 - 06			7/16" - 20	9/16" - 18	4	6.5	12	19	
- 06 - 06			9/16" - 18	9/16" - 18	6.5	6.5	16	19	
- 06 - 08			9/16" - 18	3/4" - 16	6.5	9.5	17	22	
- 08 - 06			3/4" - 16	9/16" - 18	9.5	6.5	20	19	
- 08 - 08			3/4" - 16	3/4" - 16	9.5	9.5	20	22	
- 08 - 10			3/4" - 16	7/8" - 14	9.5	12	20	27	
- 10 - 08			7/8" - 14	3/4" - 16	12	9.5	24	22	
- 10 - 10			7/8" - 14	7/8" - 14	12	12	24	27	
- 10 - 12			7/8" - 14	1 1/16" - 12	12	15	25	32	
- 12 - 10			1 1/16" - 12	7/8" - 14	15	12	28	27	
- 12 - 12			1 1/16" - 12	1 1/16" - 12	15	15	28	32	
- 16 - 16			1 5/16" - 12	1 5/16" - 12	21	21	35	38	
- 16 - 20			1 5/16" - 12	1 5/8" - 12	21	26.5	42	50	
- 20 - 20			1 5/8" - 12	1 5/8" - 12	26.5	26.5	42	50	
- 20 - 24			1 5/8" - 12	1 7/8" - 12	26.5	32	50	60	
- 24 - 24			1 7/8" - 12	1 7/8" - 12	32	32	50	60	
- 24 - 32			1 7/8" - 12	2 1/2" - 12	32	44	65	75	
- 32 - 32			2 1/2" - 12	2 1/2" - 12	44	44	65	75	

HYDRO - TEC

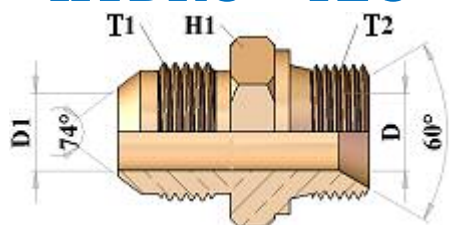

HT502505 STRIGHT ADAPTOR JIC MALE / BSP MALE

نبل ذكر سن / ذكر سن JIC

النوع	السعر	العدد	الخطوة		القياسات مع			ملاحظات
PART REF.	PRICE	QTY	THREAD		DIMENSIONS mm			REM.
			T1 - JIC	T2 - BSP	D1	D2	H1	
HT502505-04 - 02			7/16" - 20	1/8" - 19	4	3.5	14	
- 04 - 04			7/16" - 20	1/4" - 19	4	5	19	
- 04 - 06			7/16" - 20	3/8" - 19	4	8	22	
- 04 - 08			7/16" - 20	1/2" - 14	4	11.5	27	
- 05 - 04			1/2" - 20	1/4" - 19	5	5	19	
- 05 - 06			1/2" - 20	3/8" - 19	5	8	22	
- 06 - 04			9/16" - 18	1/4" - 19	6.5	5	19	
- 06 - 06			9/16" - 18	3/8" - 19	6.5	8	22	
- 06 - 08			9/16" - 18	1/2" - 14	6.5	11.5	27	
- 08 - 04			3/4" - 16	1/4" - 19	9.5	5	19	
- 08 - 06			3/4" - 16	3/8" - 19	9.5	8	22	
- 08 - 08			3/4" - 16	1/2" - 14	9.5	11.5	27	
- 08 - 10			3/4" - 16	5/8" - 14	9.5	14.5	30	
- 08 - 12			3/4" - 16	3/4" - 14	9.5	17	32	
- 10 - 06			7/8" - 14	3/8" - 19	12	8	22	
- 10 - 08			7/8" - 14	1/2" - 14	12	11.5	27	
- 10 - 12			7/8" - 14	3/4" - 14	12	17	32	
- 12 - 08			1 1/16" - 12	1/2" - 14	15	11.5	27	
- 12 - 12			1 1/16" - 12	3/4" - 14	15	17	32	
- 12 - 16			1 1/16" - 12	1" - 11	15	22.5	41	
- 14 - 12			1 3/16" - 12	3/4" - 14	17	17	32	
- 16 - 12			1 5/16" - 12	3/4" - 14	21	17	35	
- 16 - 16			1 5/16" - 12	1" - 11	21	22.5	41	
- 16 - 20			1 5/16" - 12	1".1/4 - 11	21	29	50	
- 20 - 16			1 5/8" - 12	1" - 11	26	22.5	43	
- 20 - 20			1 5/8" - 12	1".1/4 - 11	26	29	50	
- 20 - 24			1 5/8" - 12	1".1/2 - 11	26	33.5	50	
- 24 - 24			1 7/8" - 12	1".1/2 - 11	32	33.5	55	

HYDRO – TEC

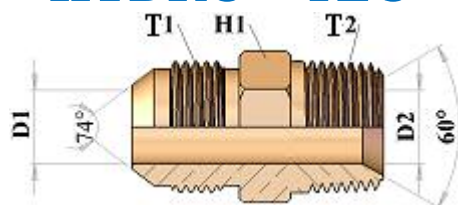

HT502507 STRIGHT ADAPTOR JIC MALE / BSPT MALE

نبل ذكر سن / BSPT / ذكر سن JIC

النوع	السعر	العدد	الخطوة		القياسات مم			ملاحظات
PART REF.	PRICE	QTY	THREAD		DIMENSIONS mm			REM.
			T1 - JIC	T2 - BSPT	D1	D2	H1	
HT502507-04 - 02			7/16" - 20	1/8" - 19	4	3.5	12	
- 04 - 04			7/16" - 20	1/4" - 19	4	5	14	
- 04 - 06			7/16" - 20	3/8" - 19	4	8	19	
- 05 - 04			1/2" - 20	1/4" - 19	5	5	14	
- 05 - 06			1/2" - 20	3/8" - 19	5	8	19	
- 05 - 08			1/2" - 20	1/2" - 14	5	11.5	22	
- 06 - 04			9/16" - 18	1/4" - 19	6.5	5	14	
- 06 - 06			9/16" - 18	3/8" - 19	6.5	8	19	
- 06 - 08			9/16" - 18	1/2" - 14	6.5	11.5	22	
- 08 - 04			3/4" - 16	1/4" - 19	9.5	5	19	
- 08 - 06			3/4" - 16	3/8" - 19	9.5	8	19	
- 08 - 08			3/4" - 16	1/2" - 14	9.5	11.5	22	
- 08 - 12			3/4" - 16	3/4" - 14	9.5	17	27	
- 10 - 06			7/8" - 14	3/8" - 19	12	8	22	
- 10 - 08			7/8" - 14	1/2" - 14	12	11.5	22	
- 10 - 12			7/8" - 14	3/4" - 14	12	17	27	
- 12 - 08			1 1/16" - 12	1/2" - 14	15	11.5	27	
- 12 - 12			1 1/16" - 12	3/4" - 14	15	17	27	
- 12 - 16			1 1/16" - 12	1" - 11	15	22.5	35	
- 16 - 12			1 5/16" - 12	3/4" - 14	21	17	35	
- 16 - 16			1 5/16" - 12	1" - 11	21	22.5	35	
- 16 - 20			1 5/16" - 12	1".1/4 - 11	21	29	43	
- 20 - 16			1 5/8" - 12	1" - 11	26	22.5	43	
- 20 - 20			1 5/8" - 12	1".1/4 - 11	26	29	44	
- 20 - 24			1 5/8" - 12	1".1/2 - 11	26	33.5	50	
- 24 - 24			1 7/8" - 12	1".1/2 - 11	32	33.5	50	
- 32 - 32			2 1/2" - 12	2" - 11	44	46	65	

HYDRO – TEC

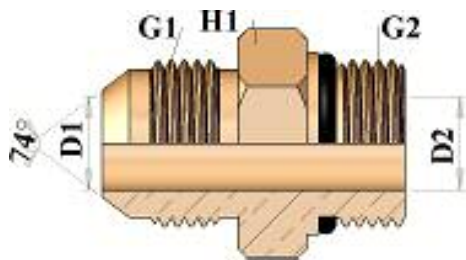

HT502530 STRAIGHT ADAPTOR JIC MALE / SEA O'RING MALE نبيل ذكر سن أورنغ / JIC ذكر سن

النوع	السعر	العدد	الخطوة		القياسات مم			ملاحظات
PART REF.	PRICE	QTY	THREAD		DIMENSIONS mm			REM.
			T1 - JIC	T2 - O'RING	D1	D2	H1	
HT502530-04 - 04			7/16" - 20	7/16" - 20	4	4	14	
- 04 - 05			7/16" - 20	1/2" - 20	4	5	16	
- 04 - 06			7/16" - 18	9/16" - 18	4	6.5	19	
- 05 - 04			1/2" - 20	7/16" - 20	5	4	14	
- 05 - 05			1/2" - 20	1/2" - 20	5	5	16	
- 05 - 06			1/2" - 20	9/16" - 18	5	6.5	19	
- 06 - 04			9/16" - 18	7/16" - 20	6.5	4	14	
- 06 - 05			9/16" - 18	1/2" - 20	6.5	5	16	
- 06 - 06			9/16" - 18	9/16" - 18	6.5	6.5	19	
- 06 - 08			9/16" - 18	3/4" - 16	6.5	9.5	22	
- 08 - 05			3/4" - 16	1/2" - 20	9.5	5	19	
- 08 - 06			3/4" - 16	9/16" - 18	9.5	6.5	19	
- 08 - 08			3/4" - 16	3/4" - 16	9.5	9.5	22	
- 08 - 12			3/4" - 16	1 1/16" - 12	9.5	15	32	
- 10 - 08			7/8" - 14	3/4" - 16	12	9.5	22	
- 10 - 10			7/8" - 14	7/8" - 14	12	12	27	
- 12 - 08			1 1/16" - 12	3/4" - 16	15	9.5	27	
- 12 - 10			1 1/16" - 12	7/8" - 14	15	12	27	
- 12 - 12			1 1/16" - 12	1 1/16" - 12	15	15	32	
- 12 - 16			1 1/16" - 12	1 5/16" - 12	15	21	38	
- 16 - 12			1 5/16" - 12	1 1/16" - 12	21	15	35	
- 16 - 16			1 5/16" - 12	1 5/16" - 12	21	21	38	
- 16 - 20			1 5/16" - 12	1 5/8" - 12	21	26.5	50	
- 20 - 20			1 5/8" - 12	1 5/8" - 12	26.5	26.5	50	
- 24 - 24			1 7/8" - 12	1 7/8" - 12	32	32	55	
- 32 - 32			2 1/2" - 12	2 1/2" - 12	35	35	70	

HYDRO – TEC

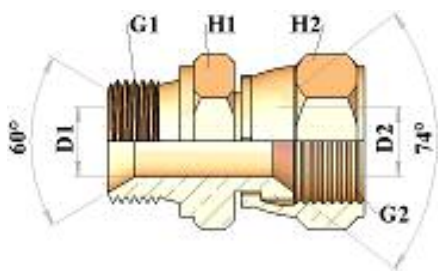

HT520525 STRIGHT ADAPTOR BSP MALE / JIC FEMALE

نبل متحرك سن JIC / ذكر سن BSP

النوع	السعر	العدد	الخطوة		القياسات مم				ملاحظات
PART REF.	PRICE	QTY	THREAD		DIMENSIONS mm				REM.
			T1 - BSP	T2 - JIC	D1	D2	H1	H2	
HT520525- 02 - 04			1/8" - 28	7/16" - 20	3.5	4	14	16	
- 02 - 05			1/8" - 28	1/2" - 20	3.5	5	14	16	
- 04 - 04			1/4" - 19	7/16" - 20	5	4	19	16	
- 04 - 05			1/4" - 19	1/2" - 20	5	5	19	16	
- 04 - 06			1/4" - 19	9/16" - 18	5	6.5	19	19	
- 04 - 08			1/4" - 19	3/4" - 16	5	9.5	19	22	
- 06 - 04			3/8" - 19	7/16" - 20	8	4	22	16	
- 06 - 05			3/8" - 19	1/2" - 20	8	5	22	16	
- 06 - 06			3/8" - 19	9/16" - 18	8	6.5	22	19	
- 06 - 08			3/8" - 19	3/4" - 16	8	9.5	22	22	
- 06 - 10			3/8" - 19	7/8" - 14	8	12	22	27	
- 08 - 04			1/2" - 14	7/16" - 20	11.5	4	27	16	
- 08 - 06			1/2" - 14	9/16" - 18	11.5	6.5	27	19	
- 08 - 08			1/2" - 14	3/4" - 16	11.5	9.5	27	22	
- 08 - 10			1/2" - 14	7/8" - 14	11.5	12	27	27	
- 08 - 12			1/2" - 14	1 1/16" -12	11.5	15	27	32	
- 12 - 08			3/4" - 14	3/4" - 16	17	9.5	32	22	
- 12 - 10			3/4" - 14	7/8" - 14	17	12	32	27	
- 12 - 12			3/4" - 14	1 1/16" -12	17	15	32	32	
- 12 - 14			3/4" - 14	1 3/16" -12	17	17	32	32	
- 12 - 16			3/4" - 14	1 5/16" -12	17	21	35	38	
- 16 - 12			1" - 11	1 1/16" -12	22.5	15	41	32	
- 16 - 16			1" - 11	1 5/16" -12	22.5	21	41	38	
- 16 - 20			1" - 11	1 5/8" -12	22.5	26	43	50	
- 20 - 16			1".1/4 - 11	1 5/16" -12	29	21	50	38	
- 20 - 20			1".1/4 - 11	1 5/8" -12	29	26	50	50	
- 20 - 24			1".1/4 - 11	1 7/8" -12	29	32	50	55	
- 24 - 24			1".1/2 - 11	1 7/8" -12	33.5	32	55	55	

HYDRO – TEC

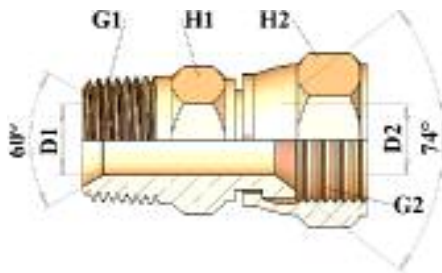

HT520725 STRIGHT ADAPTOR BSPT MALE / JIC FEMALE
 نبيل متحرك سن JIC / ذكر سن BSPT

النوع	السعر	العدد	الخطوة		القياسات مم				ملاحظات
PART REF.	PRICE	QTY	THREAD		DIMENSIONS mm				REM.
			T1 - BSP	T2 - JIC	D1	D2	H1	H2	
HT520725- 02 - 04			1/8" - 28	7/16" - 20	3.5	4	12	16	
- 02 - 05			1/8" - 28	1/2" - 20	3.5	5	14	16	
- 04 - 04			1/4" - 19	7/16" - 20	5	4	14	16	
- 04 - 05			1/4" - 19	1/2" - 20	5	5	14	16	
- 04 - 06			1/4" - 19	9/16" - 18	5	6.5	14	19	
- 04 - 08			1/4" - 19	3/4" - 16	5	9.5	19	22	
- 06 - 06			3/8" - 19	9/16" - 18	8	6.5	19	19	
- 06 - 08			3/8" - 19	3/4" - 16	8	9.5	19	22	
- 06 - 10			3/8" - 19	7/8" - 14	8	12	22	27	
- 08 - 06			1/2" - 14	9/16" - 18	11.5	6.5	22	19	
- 08 - 08			1/2" - 14	3/4" - 16	11.5	9.5	22	22	
- 08 - 10			1/2" - 14	7/8" - 14	11.5	12	22	27	
- 08 - 12			1/2" - 14	1 1/16" -12	11.5	15	27	32	
- 12 - 10			3/4" - 14	7/8" - 14	17	12	27	27	
- 12 - 12			3/4" - 14	1 1/16" -12	17	15	27	32	
- 12 - 14			3/4" - 14	1 3/16" -12	17	17	32	32	
- 12 - 16			3/4" - 14	1 5/16" -12	17	21	35	38	
- 16 - 12			1" - 11	1 1/16" -12	22.5	15	35	32	
- 16 - 16			1" - 11	1 5/16" -12	22.5	21	35	38	
- 16 - 20			1" - 11	1 5/8" -12	22.5	26	43	50	
- 20 - 20			1".1/4- 11	1 5/8" -12	29	26	44	50	
- 24 - 24			1".1/2- 11	1 7/8" -12	33.5	32	50	55	

HYDRO – TEC

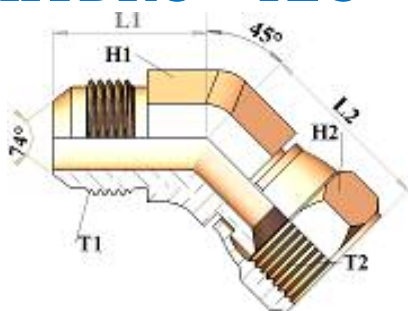

HT552525 45 ELBOW ADAPTOR JIC MALE / JIC FEMALE
نبيل نصف كوع متحرك سن JIC / ذكر سن JIC

النوع	السعر	العدد	الخطوة		القياسات مم				ملاحظات
PART REF.	PRICE	QTY	THREAD		DIMENSIONS mm				REM.
			T1 - JIC	T2 - JIC	L1	L2	H1	H2	
HT552525- 04 - 04			7/16" - 20	7/16" - 20	22	24.5	14	16	
- 05 - 05			1/2" - 20	1/2" - 20	22	26.5	14	16	
- 06 - 06			9/16" - 18	9/16" - 18	22	28.5	14	16	
- 08 - 08			3/4" - 16	3/4" - 16	26	32	19	19	
- 10 - 10			7/8" - 14	7/8" - 14	30	37	22	27	
- 12 - 12			1 1/16" -12	1 1/16" -12	32.5	38.5	27	32	
- 16 - 16			1 5/16" -12	1 5/16" -12	40	45	35	38	
- 20 - 20			1 5/8" -12	1 5/8" -12	46	51.5	44	50	
- 24 - 24			1 7/8" -12	1 7/8" -12	49	57.5	50	55	

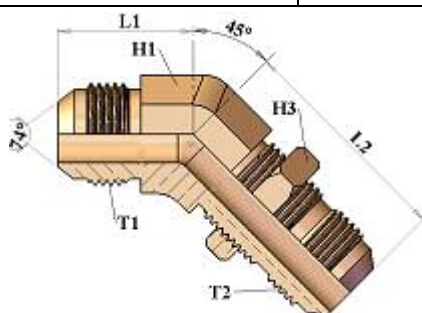

HT532523 45 ELBOW BULKHEAD ADAPTOR JIC MALE 74 CONE
نبيل نصف كوع ذكر سن JIC طويل مع عزقة كمنترول / ذكر سن JIC

النوع	السعر	العدد	الخطوة		القياسات مم				ملاحظات
PART REF.	PRICE	QTY	THREAD		DIMENSIONS mm				REM.
			T1 - JIC	T2 - JIC	L1	L2	H1	H3	
HT532523- 04 - 04			7/16" - 20	7/16" - 20	22	39	14	16	
- 05 - 05			1/2" - 20	1/2" - 20	22	39	14	16	
- 06 - 06			9/16" - 18	9/16" - 18	22	42.5	14	16	
- 08 - 08			3/4" - 16	3/4" - 16	26	49	19	19	
- 10 - 10			7/8" - 14	7/8" - 14	30	55	22	27	
- 12 - 12			1 1/16" -12	1 1/16" -12	32.5	62	27	32	
- 16 - 16			1 5/16" -12	1 5/16" -12	40	65	35	38	
- 20 - 20			1 5/8" -12	1 5/8" -12	46	67	41	50	

HYDRO – TEC

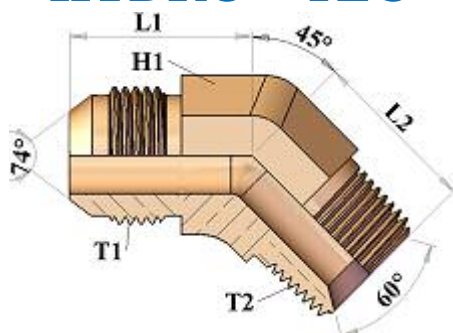

HT532507 45 ELBOW ADAPTOR JIC MALE / BSPT MALE
نبل نصف كوع ذكر سن JIC / ذكر سن BSPT

النوع PART REF.	السعر PRICE	العدد QTY	الخطوة THREAD		القياسات مم DIMENSIONS mm			ملاحظات REM.
			T1 - JIC	T2 - BSPT	L1	L2	H1	
HT532507- 04 - 02			7/16" - 20	1/8" - 28	22	18	12	
- 04 - 04			7/16" - 20	1/4" - 19	22	21	14	
- 05 - 04			1/2" - 20	1/4" - 19	22	21	14	
- 06 - 04			9/16" - 18	1/4" - 19	22	21	14	
- 06 - 06			9/16" - 18	3/8" - 19	26	26	19	
- 06 - 08			9/16" - 18	1/2" - 14	26	26	22	
- 08 - 08			3/4" - 16	1/2" - 14	28	31	22	
- 10 - 08			7/8" - 14	1/2" - 14	38	31	22	
- 12 - 12			1 1/16" - 12	3/4" - 14	32.5	31.5	27	
- 16 - 16			1 5/16" - 12	1" - 11	40	41	35	
- 20 - 20			1 5/8" - 12	1".1/4- 11	46	46	44	
- 24 - 24			1 7/8" - 12	1".1/2- 11	59	46.5	50	
- 32 - 32			2 1/2" - 12	2" - 11	58	55	65	

HYDRO – TEC

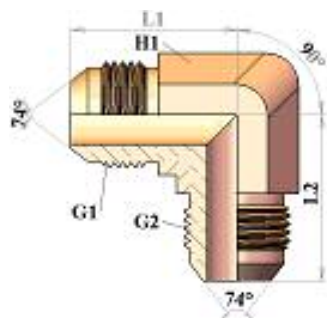

HT562525 90 ELBOW ADAPTOR JIC MALE 74° CONE

نبيل كوع سن JIC ذكر

النوع	السعر	العدد	الخطوة		القياسات مم			ملاحظات
PART REF.	PRICE	QTY	THREAD		DIMENSIONS mm			REM.
			T1 - JIC	T2 - JIC	L1	L2	H1	
HT562525- 04 - 04			7/16" - 20	7/16" - 20	22.5	22.5	12	
- 05 - 05			1/2" - 20	1/2" - 20	25	25	14	
- 06 - 06			9/16" - 18	9/16" - 18	26	26	16	
- 08 - 08			3/4" - 16	3/4" - 16	31.5	31.5	20	
- 10 - 10			7/8" - 14	7/8" - 14	36.5	36.5	24	
- 12 - 12			1 1/16" -12	1 1/16" -12	42	42	28	
- 16 - 16			1 5/16" -12	1 5/16" -12	46	46	35	
- 20 - 20			1 5/8" -12	1 5/8" -12	52	52	42	
- 24 - 24			1 7/8" -12	1 7/8" -12	59	59	50	
- 32 - 32			2 1/2" -12	2 1/2" -12	75	75	65	

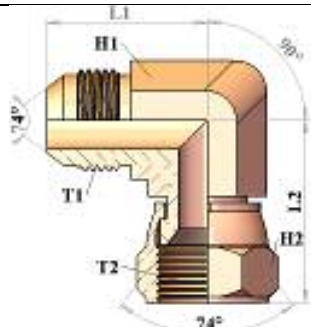

HT582525 90 ELBOW ADAPTOR JIC MALE 74° CONE /FEMAL JIC

نبيل كوع متحرك سن JIC / ذكر سن JIC

النوع	السعر	العدد	الخطوة		القياسات مم				ملاحظات
PART REF.	PRICE	QTY	THREAD		DIMENSIONS mm				REM.
			T1 - JIC	T2 - JIC	L1	L2	H1	H2	
HT582525-04 - 04			7/16" - 20	7/16" - 20	22.5	22.5	14	16	
- 05 - 05			1/2" - 20	1/2" - 20	25	25	14	16	
- 06 - 06			9/16" - 18	9/16" - 18	26	26	14	19	
- 08 - 08			3/4" - 16	3/4" - 16	31.5	31.5	19	22	
- 10 - 10			7/8" - 14	7/8" - 14	36.5	36.5	22	27	
- 12 - 12			1 1/16" -12	1 1/16" -12	42	42	27	32	
- 16 - 16			1 5/16" -12	1 5/16" -12	46	46	35	38	
- 20 - 20			1 5/8" -12	1 5/8" -12	52	52	41	50	
- 24 - 24			1 7/8" -12	1 7/8" -12	59	59	50	55	

HYDRO – TEC

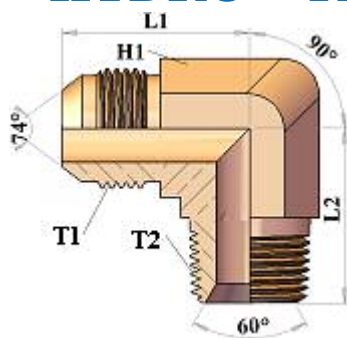

HT562507 90 ELBOW ADAPTOR JIC MALE / BSPT MALE

نبل كوع ذكر سن BSPT / ذكر سن إنكليزي JIC

النوع	السعر	العدد	الخطوة		القياسات مم			ملاحظات
PART REF.	PRICE	QTY	THREAD		DIMENSIONS mm			REM.
			T1 - JIC	T2 - BSPT	L1	L2	H1	
HT562507- 04 - 02			7/16" - 20	1/8" - 28	22.5	21	12	
- 04 - 04			7/16" - 20	1/4" - 19	26	27	14	
- 04 - 06			7/16" - 20	3/8" - 19	28.5	31	19	
- 05 - 02			1/2" - 20	1/8" - 28	26	23	14	
- 05 - 04			1/2" - 20	1/4" - 19	26	27	14	
- 05 - 06			1/2" - 20	3/8" - 19	28.5	31	19	
- 06 - 04			9/16" - 18	1/4" - 19	26	27	19	
- 06 - 06			9/16" - 18	3/8" - 19	29	31	19	
- 06 - 08			9/16" - 18	1/2" - 14	33	37	22	
- 08 - 04			3/4" - 16	1/4" - 19	31.5	31	19	
- 08 - 06			3/4" - 16	3/8" - 19	31.5	31	19	
- 08 - 08			3/4" - 16	1/2" - 14	34	37	22	
- 10 - 06			7/8" - 14	1/2" - 14	36.5	34	22	
- 10 - 08			7/8" - 14	1/2" - 14	36.5	37	22	
- 10 - 12			7/8" - 14	3/4" - 14	39.5	40.5	27	
- 12 - 08			1 1/16" -12	1/2" - 14	42	40.5	27	
- 12 - 12			1 1/16" -12	3/4" - 14	42	40.5	27	
- 12 - 16			1 1/16" -12	1" - 11	46	48	35	
- 16 - 12			1 5/16" -12	3/4" - 14	46	46	35	
- 16 - 16			1 5/16" -12	1" - 11	46	48	35	
- 16 - 20			1 5/16" -12	1".1/4 - 11	52	54	43	
- 20 - 16			1 5/8" -12	1" - 11	52	57	43	
- 20 - 20			1 5/8" -12	1".1/4- 11	59	65	44	
- 20 - 24			1 5/8" -12	1".1/2 - 11	59	65	50	
- 24 - 24			1 7/8" -12	1".1/2- 11	59	65	50	
- 24 - 32			1 7/8" -12	2" - 11	72	74	65	
- 32 - 32			2 1/2" -12	2" - 11	75	74	65	

HYDRO - TEC

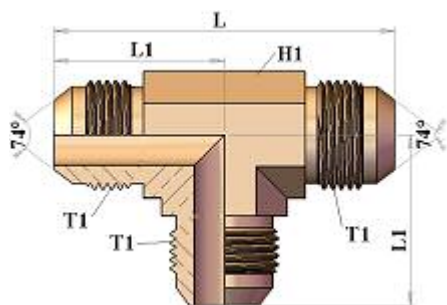

HT702525 UNION TEE ADAPTOR JIC MALE 74° CONE

مثلث سن JIC ذكر

النوع	السعر	العدد	الخطوة	القياسات مم			ملاحظات
PART REF.	PRICE	QTY	THREAD T1 - JIC	DIMENSIONS mm			REM.
				L	L1	H1	
HT702525- 04 - 04			7/16" - 20	45	22.5	12	
- 05 - 05			1/2" - 20	50	25	14	
- 06 - 06			9/16" - 18	54	26	14	
- 08 - 08			3/4" - 16	63	31.5	19	
- 10 - 10			7/8" - 14	73	36.5	22	
- 12 - 12			1 1/16" -12	84	42	27	
- 16 - 16			1 5/16" -12	92	46	36	
- 20 - 20			1 5/8" -12	104	52	41	
- 24 - 24			1 7/8" -12	118	59	50	

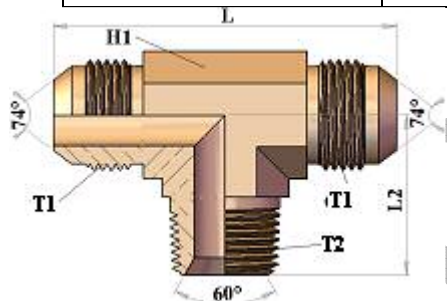

HT702507 BRANCH TEE ADAPTOR JIC MALE / BSPT MALE 74° CONE

مثلث طرفين سن JIC ذكر / وسط BSPT

النوع	السعر	العدد	الخطوة		القياسات مم				ملاحظات
PART REF.	PRICE	QTY	THREAD		DIMENSIONS mm				REM.
			T1- JIC	T2- BSPT	L	L2	H1	H2	
HT702507- 04 - 02			7/16" - 20	1/8" - 28	45	21	12	12	
- 05 - 02			1/2" - 20	1/8" - 28	50	23	14	14	
- 06 - 04			9/16" - 18	1/4" - 19	54	27	14	14	
- 08 - 06			3/4" - 16	3/8" - 19	63	31	19	19	
- 10 - 08			7/8" - 14	1/2" - 14	73	37	22	22	
- 12 - 12			1 1/16" -12	3/4" - 14	84	40.5	27	27	
- 16 - 16			1 5/16" -12	1" - 11	92	46	36	36	
- 20 - 20			1 5/8" -12	1 1/4" - 11	104	54	36	41	
- 24 - 24			1 7/8" -12	1 1/2" - 11	118	60	36	50	

HYDRO – TEC

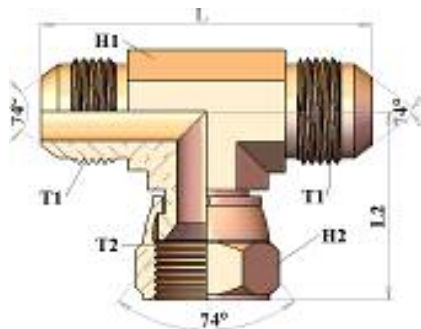

HT712525 UNION TEE ADAPTOR JIC MALE / JIC FEMALE 74° CONE
مثلث سن JIC طرفين ذكر وسط متحرك

النوع	السعر	العدد	الخطوة		القياسات مم				ملاحظات
PART REF.	PRICE	QTY	THREAD		DIMENSIONS mm				REM.
			T1 - JIC	T2 - JIC	L	L2	H1	H2	
HT712525- 04 - 04			7/16" - 20	7/16" - 20	45	22.5	12	16	
- 05 - 05			1/2" - 20	1/2" - 20	50	25	14	16	
- 06 - 06			9/16" - 18	9/16" - 18	54	26	14	19	
- 08 - 08			3/4" - 16	3/4" - 16	63	31.5	19	22	
- 10 - 10			7/8" - 14	7/8" - 14	73	36.5	22	27	
- 12 - 12			1 1/16" -12	1 1/16" -12	84	42	27	32	
- 16 - 16			1 5/16" -12	1 5/16" -12	92	46	36	38	
- 20 - 20			1 5/8" -12	1 5/8" -12	104	52	41	50	

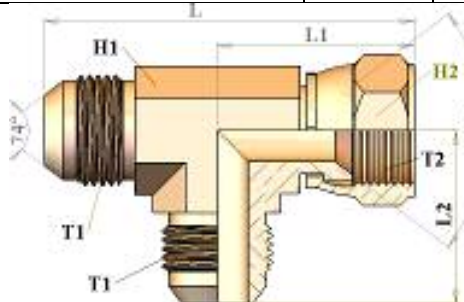

HT722525 RUN TEE ADAPTOR JIC MALE / JIC FEMALE 74° CONE
مثلث سن JIC طرف ووسط ذكر وطرف متحرك

النوع	السعر	العدد	الخطوة		القياسات مم					ملاحظات
PART REF.	PRICE	QTY	THREAD		DIMENSIONS mm					REM.
			T1 - JIC	T2 - JIC	L	L1	L2	H1	H2	
HT722525-04 - 04			7/16" - 20	7/16" - 20	52	26	26	14	16	
- 05 - 05			1/2" - 20	1/2" - 20	54	28	26	14	16	
- 06 - 06			9/16" - 18	9/16" - 18	58	31	27	14	19	
- 08 - 08			3/4" - 16	3/4" - 16	67	35.5	31.5	19	22	
- 10 - 10			7/8" - 14	7/8" - 14	78.5	42	36.5	22	27	
- 12 - 12			1 1/16" -12	1 1/16" -12	87.5	46.5	42	27	32	
- 16 - 16			1 5/16" -12	1 5/16" -12	97.5	51.5	46	36	38	
- 20 - 20			1 5/8" -12	1 5/8" -12	111	59	52	41	50	
- 24 - 24			1 7/8" -12	1 7/8" -12	126	67	59	50	55	

HYDRO – TEC

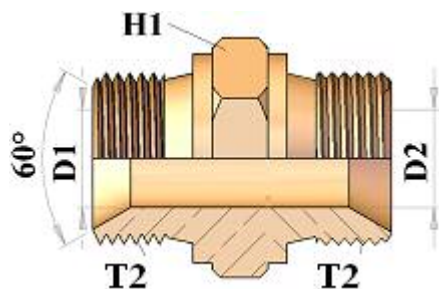

HT500505 STRAIGHT ADAPTOR BSP MALE / BSP MALE

نبيل ذكر سن
BSP

النوع	السعر	العدد	الخطوة		القياسات مم			ملاحظات
PART REF.	PRICE	QTY	THREAD		DIMENSIONS mm			REM.
			T1 - BSP	T2 - BSP	D1	D2	H1	
HT500505 - 02 - 02			1/8" - 28	1/8" - 28	3.5	3.5	14	
- 04 - 02			1/4" - 19	1/8" - 28	5	3.5	19	
- 04 - 04			1/4" - 19	1/4" - 19	5	5	19	
- 06 - 02			3/8" - 19	1/8" - 28	8	3.5	22	
- 06 - 04			3/8" - 19	1/4" - 19	8	5	22	
- 06 - 06			3/8" - 19	3/8" - 19	8	8	22	
- 08 - 04			1/2" - 14	1/4" - 19	11.5	5	27	
- 08 - 06			1/2" - 14	3/8" - 19	11.5	8	27	
- 08 - 08			1/2" - 14	1/2" - 14	11.5	11.5	27	
- 10 - 08			5/8" - 14	1/2" - 14	14.5	11.5	30	
- 10 - 10			5/8" - 14	5/8" - 14	14.5	14.5	30	
- 12 - 08			3/4" - 14	1/2" - 14	17	11.5	32	
- 12 - 10			3/4" - 14	5/8" - 14	17	14.5	32	
- 12 - 12			3/4" - 14	3/4" - 14	17	17	32	
- 16 - 08			1" - 11	1/2" - 14	22.5	11.5	41	
- 16 - 10			1" - 11	5/8" - 14	22.5	14.5	41	
- 16 - 12			1" - 11	3/4" - 14	22.5	7	41	
- 16 - 16			1" - 11	1" - 11	22.5	22.5	41	
- 20 - 12			1".1/4 - 11	3/4" - 14	29	17	50	
- 20 - 16			1".1/4 - 11	1" - 11	29	22.5	50	
- 20 - 20			1".1/4 - 11	1".1/4 - 11	29	29	50	
- 24 - 16			1".1/2 - 11	1" - 11	33.5	22.5	55	
- 24 - 20			1".1/2 - 11	1".1/4 - 11	33.5	29	55	
- 24 - 24			1".1/2 - 11	1".1/2 - 11	33.5	33.5	55	
- 32 - 20			2" - 11	1".1/4 - 11	46	29	70	
- 32 - 24			2" - 11	1".1/2 - 11	46	33.5	70	
- 32 - 32			2" - 11	2" - 11	46	46	70	

HYDRO - TEC

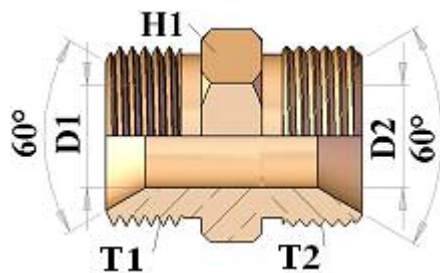

HT500404 STRAIGHT ADAPTOR MALE / BSP MALE

نبيل ذكر سن BSP مسدس صغير

النوع	السعر	العدد	الخطوة		القياسات مم			ملاحظات
PART REF.	PRICE	QTY	THREAD		DIMENSIONS mm			REM.
			T1 - BSP	T2 - BSP	D1	D2	H1	
HT500404 - 02 - 02			1/8" - 28	1/8" - 28	3.5	3.5	12	
- 04 - 02			1/4" - 19	1/8" - 28	5	3.5	14	
- 04 - 04			1/4" - 19	1/4" - 19	5	5	14	
- 06 - 02			3/8" - 19	1/8" - 28	8	3.5	19	
- 06 - 04			3/8" - 19	1/4" - 19	8	5	19	
- 06 - 06			3/8" - 19	3/8" - 19	8	8	19	
- 08 - 04			1/2" - 14	1/4" - 19	11.5	5	22	
- 08 - 06			1/2" - 14	3/8" - 19	11.5	8	22	
- 08 - 08			1/2" - 14	1/2" - 14	11.5	11.5	22	
- 10 - 08			5/8" - 14	1/2" - 14	14.5	11.5	24	
- 10 - 10			5/8" - 14	5/8" - 14	14.5	14.5	24	
- 12 - 08			3/4" - 14	1/2" - 14	17	11.5	27	
- 12 - 10			3/4" - 14	5/8" - 14	17	14.5	27	
- 12 - 12			3/4" - 14	3/4" - 14	17	17	27	
- 16 - 08			1" - 11	1/2" - 14	22.5	11.5	35	
- 16 - 10			1" - 11	5/8" - 14	22.5	14.5	35	
- 16 - 12			1" - 11	3/4" - 14	22.5	7	35	
- 16 - 16			1" - 11	1" - 11	22.5	22.5	35	
- 20 - 12			1".1/4 - 11	3/4" - 14	29	17	46	
- 20 - 16			1".1/4 - 11	1" - 11	29	22.5	46	
- 20 - 20			1".1/4 - 11	1".1/4 - 11	29	29	46	
- 24 - 16			1".1/2 - 11	1" - 11	33.5	22.5	50	
- 24 - 20			1".1/2 - 11	1".1/4 - 11	33.5	29	50	
- 24 - 24			1".1/2 - 11	1".1/2 - 11	33.5	33.5	50	
- 32 - 20			2" - 11	1".1/4 - 11	46	29	60	
- 32 - 24			2" - 11	1".1/2 - 11	46	33.5	60	
- 32 - 32			2" - 11	2" - 11	46	46	60	

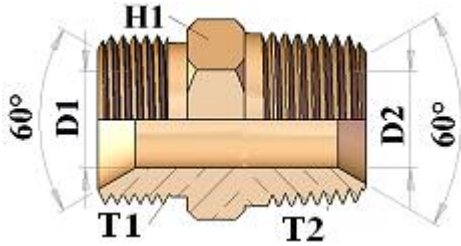

HT500407 STRAIGHT ADAPTOR MALE BSP / MALE BSPT

نبيل ذكر سن BSPT / ذكر سن BSP مسدس صغير

النوع	السعر	العدد	الخطوة		القياسات مم			ملاحظات
PART REF.	PRICE	QTY	THREAD		DIMENSIONS mm			REM.
			T1 - BSP	T2 - BSPT	D1	D2	H1	
HT500407- 02 - 02			1/8" - 28	1/8" - 28	3.5	3.5	12	
- 02 - 04			1/8" - 28	1/4" - 19	3.5	5	14	
- 04 - 02			1/4" - 19	1/8" - 28	5	3.5	14	
- 04 - 04			1/4" - 19	1/4" - 19	5	5	14	
- 04 - 06			1/4" - 19	3/8" - 19	5	8	19	
- 04 - 08			1/4" - 19	1/2" - 14	5	11.5	19	
- 06 - 04			3/8" - 19	1/4" - 19	8	5	19	
- 06 - 06			3/8" - 19	3/8" - 19	8	8	22	
- 06 - 08			3/8" - 19	1/2" - 14	8	11.5	22	
- 08 - 04			1/2" - 14	1/4" - 19	11.5	5	22	
- 08 - 06			1/2" - 14	3/8" - 19	11.5	8	22	
- 08 - 08			1/2" - 14	1/2" - 14	11.5	11.5	22	
- 08 - 10			1/2" - 14	5/8" - 14	11.5	14.5	27	
- 08 - 12			1/2" - 14	3/4" - 14	11.5	17	27	
- 10 - 08			5/8" - 14	1/2" - 14	14.5	11.5	27	
- 12 - 08			3/4" - 14	1/2" - 14	17	11.5	27	
- 12 - 12			3/4" - 14	3/4" - 14	17	17	27	
- 12 - 16			3/4" - 14	1" - 11	17	22.5	35	
- 16 - 08			1" - 11	1/2" - 14	22.5	11.5	35	
- 16 - 12			1" - 11	3/4" - 14	22.5	17	35	
- 16 - 16			1" - 11	1" - 11	22.5	22.5	35	
- 16 - 20			1" - 11	1" 1/4 - 11	22.5	29	44	
- 20 - 12			1".1/4 - 11	3/4" - 14	29	17	44	
- 20 - 16			1".1/4 - 11	1" - 11	29	22.5	44	
- 20 - 20			1".1/4 - 11	1".1/4 - 11	29	29	44	
- 24 - 16			1".1/2 - 11	1" - 11	33.5	22.5	50	
- 24 - 20			1".1/2 - 11	1".1/4 - 11	33.5	29	50	
- 24 - 24			1".1/2 - 11	1".1/2 - 11	33.5	33.5	50	
- 32 - 20			2" - 11	1".1/4 - 11	46	29	50	
- 32 - 24			2" - 11	1".1/2 - 11	46	33.5	65	
- 32 - 32			2" - 11	2" - 11	46	46	65	

HYDRO – TEC

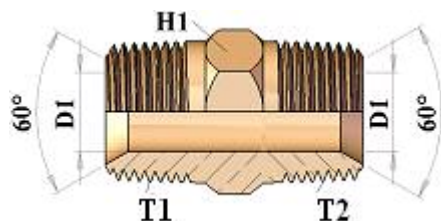

HT500707 STRAIGHT ADAPTOR BEST MALE / BEST MALE
نبيل ذكر سن BSPT

النوع	السعر	العدد	الخطوة		القياسات مم			ملاحظات
PART REF.	PRICE	QTY	THREAD		DIMENSIONS mm			REM.
			G1- BSPT	G2 - BSPT	D1	D2	H1	
HT500707 - 02 - 02			1/8" - 28	1/8" - 28	3.5	3.5	12	
- 02 - 04			1/8" - 28	1/4" - 19	3.5	5	14	
- 02 - 06			1/8" - 28	3/8" - 19	3.5	8	19	
- 04 - 04			1/4" - 19	1/4" - 19	5	5	14	
- 04 - 06			1/4" - 19	3/8" - 19	5	8	19	
- 04 - 08			1/4" - 19	1/2" - 14	5	11.5	22	
- 06 - 06			3/8" - 19	3/8" - 19	8	8	19	
- 06 - 08			3/8" - 19	1/2" - 14	8	11.5	22	
- 06 - 12			3/8" - 19	3/4" - 14	8	17	27	
- 08 - 08			1/2" - 14	1/2" - 14	11.5	11.5	22	
- 08 - 12			1/2" - 14	3/4" - 14	11.5	17	27	
- 08 - 16			1/2" - 14	1" - 11	11.5	22.5	35	
- 12 - 12			3/4" - 14	3/4" - 14	17	17	27	
- 12 - 16			3/4" - 14	1" - 11	22.5	17	35	
- 16 - 16			1" - 11	1" - 11	22.5	22.5	35	
- 16 - 20			1" - 11	1".1/4 - 11	22.5	29	43	
- 20 - 20			1".1/4 - 11	1".1/4 - 11	29	29	43	
- 20 - 24			1".1/4 - 11	1".1/2 - 11	29	33.5	50	
- 24 - 24			1".1/2 - 11	1".1/2 - 11	33.5	33.5	50	

HYDRO – TEC

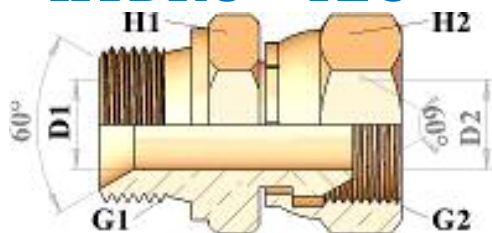

HT520505 STRAIGHT ADAPTOR BSP MALE / BSP FEMALE (C/B NUT)

نبل أنثى سن / بى سى ن ذكى سن

النوع	السعر	العدد	الخطوة		القياسات مم				ملاحظات
PART REF.	PRICE	QTY	THREAD		DIMENSIONS mm				REM.
			T1 - BSP	T2 - BSP	D1	D2	H1	H2	
HT520505 - 04 - 04			1/4" - 19	1/4" - 19	5	5	19	19	
- 04 - 06			1/4" - 19	3/8" - 19	5	8	19	22	
- 04 - 08			1/4" - 19	3/8" - 19	5	11.5	19	27	
- 06 - 04			3/8" - 19	1/4" - 19	8	5	22	19	
- 06 - 06			3/8" - 19	3/8" - 19	8	8	22	22	
- 06 - 08			3/8" - 19	1/2" - 14	8	11.5	22	27	
- 08 - 06			1/2" - 14	3/8" - 19	11.5	8	27	22	
- 08 - 08			1/2" - 14	1/2" - 14	11.5	11.5	27	27	
- 08 - 12			1/2" - 14	3/4" - 14	11.5	17	27	32	
- 10 - 10			5/8" - 14	5/8" - 14	13.5	13.5	30	30	
- 12 - 08			3/4" - 14	1/2" - 14	17	11.5	32	27	
- 12 - 12			3/4" - 14	3/4" - 14	17	17	32	32	
- 12 - 16			3/4" - 14	1" - 11	17	22.5	32	41	
- 16 - 12			1" - 11	3/4" - 14	22.5	17	41	32	
- 16 - 16			1" - 11	1" - 11	22.5	22.5	41	41	
- 16 - 20			1" - 11	1".1/4 - 11	22.5	29	41	50	
- 20 - 16			1".1/4 - 11	1" - 11	29	22.5	50	41	
- 20 - 20			1".1/4 - 11	1".1/4 - 11	29	29	50	50	
- 20 - 24			1".1/4 - 11	1".1/2 - 11	29	33.5	50	55	
- 24 - 20			1".1/2 - 11	1".1/4 - 11	33.5	29	55	50	
- 24 - 24			1".1/2 - 11	1".1/2 - 11	33.5	33.5	55	55	

HYDRO – TEC

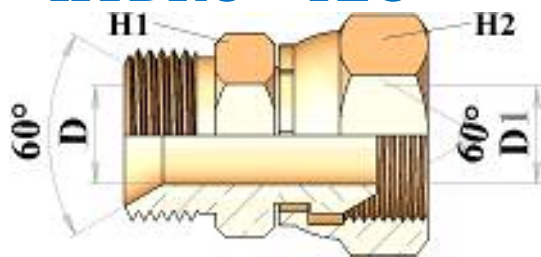

HT520405 STRAIGHT ADAPTOR BSP MALE / BSP FEMALE (C/B NUT)
نبل أنثى سن / ذكر مسدس صغير سن BSP

النوع	السعر	العدد	الخطوة		القياسات مم				ملاحظات
PART REF.	PRICE	QTY	THREAD		DIMENSIONS mm				REM.
			T1 - BSP	T2 - BSP	D1	D2	H1	H2	
HT520405 - 04 - 04			1/4" - 19	1/4" - 19	5	5	14	19	
- 06 - 06			3/8" - 19	3/8" - 19	8	8	19	22	
- 08 - 08			1/2" - 14	1/2" - 14	11.5	11.5	22	27	
- 12 - 12			3/4" - 14	3/4" - 14	17	17	27	32	
- 16 - 16			1" - 11	1" - 11	22.5	22.5	35	41	
- 20 - 20			1".1/4 - 11	1".1/4 - 11	29	29	44	50	
- 24 - 24			1".1/2 - 11	1".1/2 - 11	33.5	33.5	50	55	

HYDRO - TEC

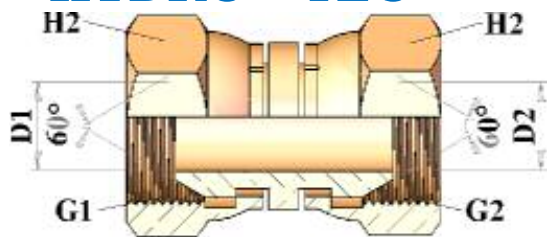

HT510505 STRAIGHT ADAPTOR BSP FEMALE / BSP FEMALE (C/B NUT)

نبيل أنثى سن BSP

النوع	السعر	العدد	الخطوة	القياسات مم		ملاحظات
PART REF.	PRICE	QTY	THREAD	DIMENSIONS mm		REM.
			T1 - BSP	D1	H2	
HT510505 - 04 - 04			1/4" - 19	5	19	
- 06 - 06			3/8" - 19	8	22	
- 08 - 08			1/2" - 14	11.5	27	
- 10 - 10			5/8" - 14	14.5	28	
- 12 - 12			3/4" - 14	17	32	
- 16 - 16			1" - 11	22.5	38	
- 20 - 20			1".1/4 - 11	29	50	
- 24 - 24			1".1/2 - 11	33.5	60	

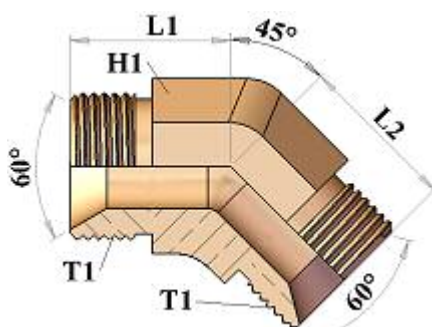

HT530404 45° ELBOW ADAPTOR BSP MALE / BSP MALE

نبيل نصف كوع ذكرين سن BSP مسدس صغير

النوع	السعر	العدد	الخطوة	القياسات مم			ملاحظات
PART REF.	PRICE	QTY	THREAD	DIMENSIONS mm			REM.
			T1 - BSP	L1	L2	H1	
HT530404- 04 - 04			1/4" - 19	21	21	14	
- 06 - 06			3/8" - 19	26	26	19	
- 08 - 08			1/2" - 14	31	31	22	
- 12 - 12			3/4" - 14	31.5	31.5	27	
- 16 - 16			1" - 11	41	41	35	
- 20 - 20			1 1/4" - 11	45	45	44	
- 24 - 24			1 1/2" - 11	47	47	50	
- 32 - 32			2" - 11	56	56	65	

HYDRO – TEC

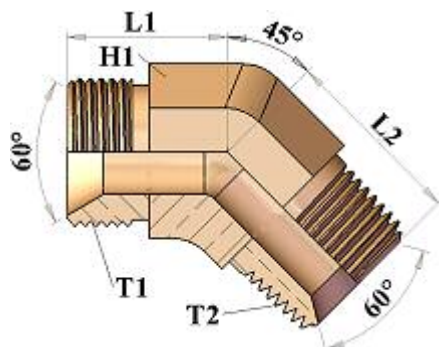

HT530407 45° ELBOW ADAPTOR BSP MALE / BSPT MALE

نبيل نصف كوع ذكر BSPT / ذكر BSP مسدس صغير

النوع PART REF.	السعر PRICE	العدد QTY	الخطوة THREAD		القياسات مم DIMENSIONS mm			ملاحظات REM.
			T1 - BSP	T2 - BSPT	L1	L2	H1	
HT530407- 04 - 04			1/4" - 19	1/4" - 19	21	21	14	
- 06 - 06			3/8" - 19	3/8" - 19	25	26	19	
- 08 - 08			1/2" - 14	1/2" - 14	28	31	22	
- 12 - 12			3/4" - 14	3/4" - 14	33	31.5	27	
- 16 - 16			1" - 11	1" - 11	38	41	35	
- 20 - 20			1 1/4" - 11	1 1/4" - 11	45	46	44	
- 24 - 24			1 1/2" - 11	1 1/2" - 11	47	48	50	
- 32 - 32			2" - 11	2" - 11	56	55	65	

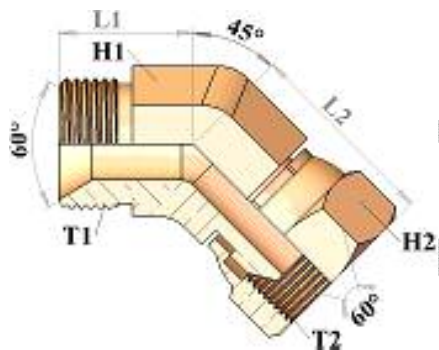

HT550405 45° ELBOW ADAPTOR BSP MALE / BSP FEMALE

نبيل نصف كوع متحرك سن BSP / ذكر سن BSP مسدس صغير

النوع PART REF.	السعر PRICE	العدد QTY	الخطوة THREAD		القياسات مم DIMENSIONS mm				ملاحظات REM.
			T1 - BSP	T2 - BSP	L1	L2	H1	H2	
HT550405-04 - 04			1/4" - 19	1/4" - 19	21	23	14	19	
- 06 - 06			3/8" - 19	3/8" - 19	25	28	19	22	
- 08 - 08			1/2" - 14	1/2" - 14	28	29.5	22	27	
- 12 - 12			3/4" - 14	3/4" - 14	33	37	27	32	
- 16 - 16			1" - 11	1" - 11	38	46	35	41	
- 20 - 20			1" 1/4 - 11	1" 1/4 - 11	45	51.5	41	50	
- 24 - 24			1" 1/2 - 11	1" 1/2 - 11	47	55	50	55	

HYDRO – TEC

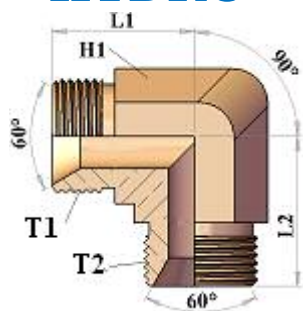

HT560404 45° ELBOW ADAPTOR BSP MALE / BSP MALE

نبل كوع ذكر سن BSP مسدس صغير

النوع	السعر	العدد	الخطوة		القياسات مم			ملاحظات
PART REF.	PRICE	QTY	THREAD		DIMENSIONS mm			REM.
			T1 - BSP	T2 - BSP	L1	L2	H1	
HT560404 - 04 - 04			1/4" - 19	1/4" - 19	25	25	14	
- 06 - 06			3/8" - 19	3/8" - 19	29	29	19	
- 08 - 08			1/2" - 14	1/2" - 14	33	33	22	
- 12 - 12			3/4" - 14	3/4" - 14	38	38	27	
- 16 - 16			1" - 11	1" - 11	45	45	35	
- 20 - 20			1" 1/4 - 11	1" 1/4 - 11	52	52	41	
- 24 - 24			1" 1/2 - 11	1" 1/2 - 11	59	59	50	

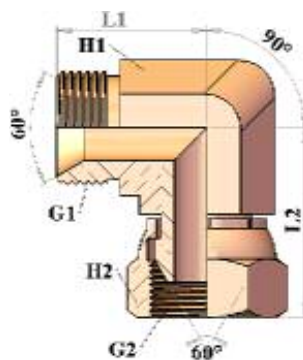

HT580405 90° ELBOW ADAPTOR BSP MALE / BSP FEMALE (C/B NUT)

نبل كوع أنثى سن BSP / ذكر سن BSP

النوع	السعر	العدد	الخطوة		القياسات مم				ملاحظات
PART REF.	PRICE	QTY	THREAD		DIMENSIONS mm				REM.
			T1 - BSP	T2 - BSP	L	L1	H	H1	
HT580405- 04 - 04			1/4" - 19	1/4" - 19	25	28	14	19	
- 06 - 06			3/8" - 19	3/8" - 19	29	31	19	22	
- 08 - 08			1/2" - 14	1/2" - 14	33	37	22	27	
- 12 - 12			3/4" - 14	3/4" - 14	38	45	27	32	
- 16 - 16			1" - 11	1" - 11	45	52	35	41	
- 20 - 20			1" 1/4 - 11	1" 1/4 - 11	52	62	41	50	
- 24 - 24			1" 1/2 - 11	1" 1/2 - 11	59	73	50	55	

HYDRO – TEC

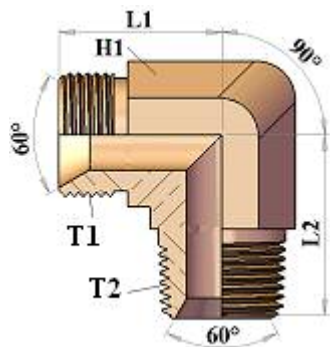

HT560407 90° ELBOW ADAPTOR BSP MALE / BSPT MALE

نبيل كوع ذكر سن BSPT / ذكر سن BSP مسدس صغير

النوع PART REF.	السعر PRICE	العدد QTY	الخطوة THREAD		القياسات مم DIMENSIONS mm			ملاحظات REM.
			T1 - BSP	T2 - BSPT	L1	L2	H1	
HT560407- 04 - 04			1/4" - 19	1/4" - 19	21	21	14	
- 06 - 06			3/8" - 19	3/8" - 19	25	26	19	
- 08 - 08			1/2" - 14	1/2" - 14	28	31	22	
- 12 - 12			3/4" - 14	3/4" - 14	33	31.5	27	
- 16 - 16			1" - 11	1" - 11	38	41	35	
- 20 - 20			1 1/4" - 11	1 1/4" - 11	45	46	44	
- 24 - 24			1 1/2" - 11	1 1/2" - 11	47	48	50	
- 32 - 32			2" - 11	2" - 11	56	55	65	

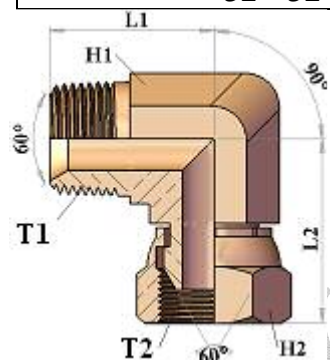

HT580705 90° ELBOW ADAPTOR BSPT MALE / BSP FEMALE (C/B NUT)

نبيل كوع متحرك سن BSP / ذكر سن BSPT

النوع PART REF.	السعر PRICE	العدد QTY	الخطوة THREAD		القياسات مم DIMENSIONS mm				ملاحظات REM.
			T1 - BSPT	T2 - BSP	L	L1	H	H1	
HT580705- 04 - 04			1/4" - 19	1/4" - 19	27	28	14	19	
- 06 - 06			3/8" - 19	3/8" - 19	31	31	19	22	
- 08 - 08			1/2" - 14	1/2" - 14	37	37	22	27	
- 12 - 12			3/4" - 14	3/4" - 14	40.5	45	27	32	
- 16 - 16			1" - 11	1" - 11	58	52	35	41	
- 20 - 20			1" 1/4 - 11	1" 1/4 - 11	57	62	41	50	
- 24 - 24			1" 1/2 - 11	1" 1/2 - 11	65	73	50	55	

HYDRO – TEC

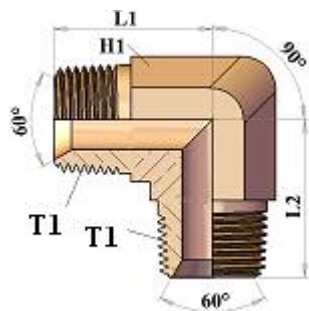

HT560707 90° ELBOW ADAPTOR BSPT MALE

نبيل كوع ذكر BSPT

النوع	السعر	العدد	الخطوة	القياسات مم			ملاحظات
PART REF.	PRICE	QTY	THREAD	DIMENSIONS mm			REM.
			T1 - BSPT	L1	L2	H1	
HT560707- 04 - 04			1/4" - 19	21	21	14	
- 06 - 06			3/8" - 19	25	26	19	
- 08 - 08			1/2" - 14	28	31	22	
- 12 - 12			3/4" - 14	33	31.5	27	
- 16 - 16			1" - 11	38	41	35	
- 20 - 20			1 1/4" - 11	45	46	44	
- 24 - 24			1 1/2" - 11	47	48	50	
- 32 - 32			2" - 11	56	55	65	

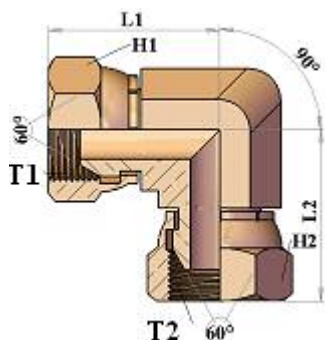

HT570505 90° ELBOW ADAPTOR BSP FEMALE / BSP FEMALE (C/B NUT)

نبيل كوع طرفين متحرك سن BSP

النوع	السعر	العدد	الخطوة		القياسات مم				ملاحظات
PART REF.	PRICE	QTY	THREAD		DIMENSIONS mm				REM.
			T1 - BSP	T2 - BSP	L1	L2	H1	H2	
HT570505- 04 - 04			1/4" - 19	1/4" - 19	28	28	14	19	
- 06 - 06			3/8" - 19	3/8" - 19	31	31	19	22	
- 08 - 08			1/2" - 14	1/2" - 14	37	37	24	27	
- 12 - 12			3/4" - 14	3/4" - 14	45	45	27	32	
- 16 - 16			1" - 11	1" - 11	54	54	35	41	
- 20 - 20			1".1/4- 11	1".1/4- 11	59.5	59.5	41	50	
- 24 - 24			1".1/2- 11	1".1/4- 11	67	67	50	55	

HYDRO - TEC

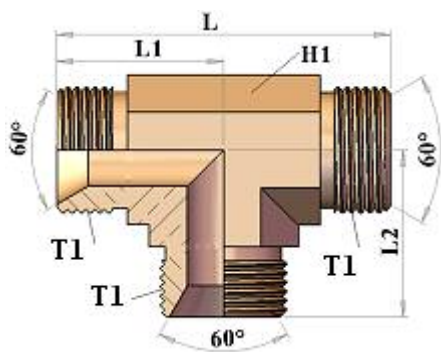

HT700404 UNION TEE BSP MALE
مثلث ٣ أطراف سن BSP

النوع	السعر	العدد	الخطوة	القياسات مم				ملاحظات
PART REF.	PRICE	QTY	THREAD	DIMENSIONS mm				REM.
			T1 - BSP	L	L1	L2	H1	
HT700404 - 04 - 04-04			1/4" - 19	50	25	25	14	
- 06 - 06 - 06			3/8" - 19	52	29	29	19	
- 08 - 08 - 08			1/2" - 14	66	33	33	22	
- 12 - 12 - 12			3/4" - 14	76	38	38	27	
- 16 - 16 - 16			1" - 11	90	45	45	36	
- 20 - 20 - 20			1"1/4 - 11	104	52	52	41	
- 24 - 24 - 24			1"1/2 - 11	118	59	59	50	

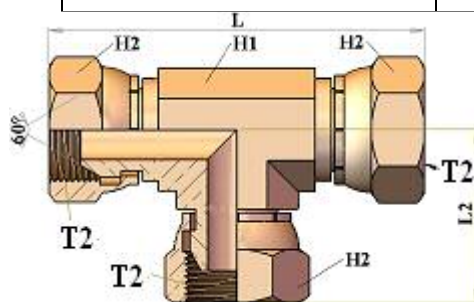

HT730505 UNION TEE BSP FEMALE
مثلث ٣ أطراف متحرك سن BSP

النوع	السعر	العدد	الخطوة		القياسات مم				ملاحظات
PART REF.	PRICE	QTY	THREAD		DIMENSIONS mm				REM.
			T1 - BSP	T2 - BSP	L	L2	H1	H2	
HT730505 - 04 - 04-04			1/4" - 19	1/4" - 19	56	28	14	19	
- 06 - 06 - 06			3/8" - 19	3/8" - 19	62	31	19	22	
- 08 - 08 - 08			1/2" - 14	1/2" - 14	74	37	22	27	
- 12 - 12 - 12			3/4" - 14	3/4" - 14	90	45	27	32	
- 16 - 16 - 16			1" - 11	1" - 11	108	54	35	41	
- 20 - 20 - 20			1".1/4 - 11	1".1/4 - 11	124	62	41	50	
- 24 - 24 - 24			1".1/2 - 11	1".1/4 - 11	146	73	50	55	

HYDRO - TEC

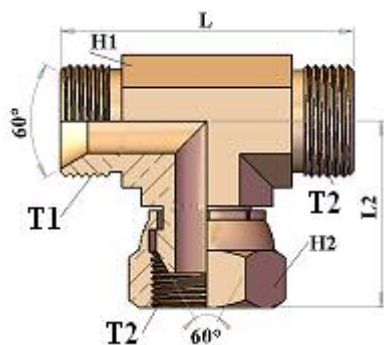

HT710405 BRANCH TEE BSP MALE / BSP FEMALE

مثلث طرفين ذكر سن BSP / وسط متحرك سن BSP

النوع PART REF.	السعر PRICE	العدد QTY	الخطوة THREAD		القياسات مم DIMENSIONS mm				ملاحظات REM.
			T1 - BSP	T2 - BSP	L	L2	H1	H2	
HT710405 - 04 - 04-04			1/4" - 19	1/4" - 19	50	28	14	19	
- 06 - 06 - 06			3/8" - 19	3/8" - 19	58	31	19	22	
- 08 - 08 - 08			1/2" - 14	1/2" - 14	66	37	22	27	
- 12 - 12 - 12			3/4" - 14	3/4" - 14	76	45	27	36	
- 16 - 16 - 16			1" - 11	1" - 11	90	54	36	41	
- 20 - 20- 20			1".1/4 - 11	1".1/4 - 11	104	62	41	50	
- 24 - 24- 24			1".1/2 - 11	1".1/4 - 11	118	73	50	55	

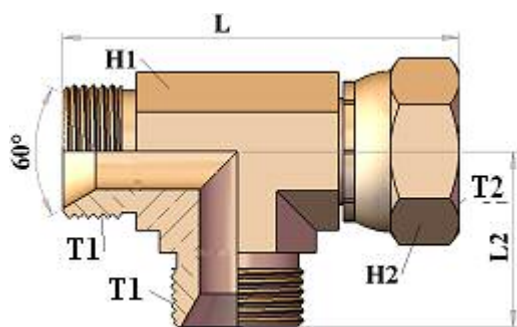

HT720405 RUN TEE BSP MALE / BSP FEMALE

مثلث طرف ووسط ذكر سن BSP / طرف متحرك سن BSP

النوع PART REF.	السعر PRICE	العدد QTY	الخطوة THREAD		القياسات مم DIMENSIONS mm				ملاحظات REM.
			T1 - BSP	T2 - BSP	L	L2	H1	H2	
HT720405 - 04 - 04-04			1/4" - 19	1/4" - 19	53	25	14	19	
- 06 - 06 - 06			3/8" - 19	3/8" - 19	60	29	19	22	
- 08 - 08 - 08			1/2" - 14	1/2" - 14	70	33	22	27	
- 12 - 12 - 12			3/4" - 14	3/4" - 14	83	38	27	36	
- 16 - 16 - 16			1" - 11	1" - 11	99	45	36	41	
- 20 - 20- 20			1".1/4- 11	1".1/4- 11	114	52	41	50	
- 24 - 24- 24			1".1/2- 11	1".1/4- 11	132	59	50	55	

HYDRO – TEC

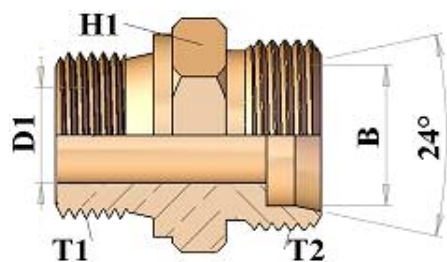

HT500615 STRAIGHT ADAPTOR BSP MALE FLAT / METRIC MALE

نبيل ذكر متري / ذكر BSP وجه مسطح

النوع	السعر	العدد	الخطوة		القياسات مم			ملاحظات
PART REF.	PRICE	QTY	THREAD		DIMENSIONS mm			REM.
			T1 - BSP	T2-METRIC	D1	B	H1	
HT500615- 02 - 10			1/8" - 28	10 x 1	3.5	5	14	
- 02 - 12			1/8" - 28	12 x 1.5	3.5	6	14	
- 04 - 12			1/4" - 19	12 x 1.5	5	6	19	
- 04 - 14			1/4" - 19	14 x 1.5	5	8	19	
- 04 - 16			1/4" - 19	16 x 1.5	5	10	19	
- 04 - 18			1/4" - 19	18 x 1.5	5	12	19	
- 04 - 22			1/4" - 19	22 x 1.5	5	15	22	
- 06 - 12			3/8" - 19	12 x 1.5	8	6	22	
- 06 - 14			3/8" - 19	14 x 1.5	8	8	22	
- 06 - 16			3/8" - 19	16 x 1.5	8	10	22	
- 06 - 18			3/8" - 19	18 x 1.5	8	12	22	
- 06 - 20			3/8" - 19	20 x 1.5	8	12	22	
- 06 - 22			3/8" - 19	22 x 1.5	8	15	22	
- 06 - 24			3/8" - 19	24 x 1.5	8	16	24	
- 08 - 12			1/2" - 14	12 x 1.5	11.5	6	27	
- 08 - 14			1/2" - 14	14 x 1.5	11.5	8	27	
- 08 - 16			1/2" - 14	16 x 1.5	11.5	10	27	
- 08 - 18			1/2" - 14	18 x 1.5	11.5	12	27	
- 08 - 22			1/2" - 14	22 x 1.5	11.5	15	27	
- 08 - 24			1/2" - 14	24 x 1.5	11.5	16	27	
- 08 - 26			1/2" - 14	26 x 1.5	11.5	18	27	
- 08 - 30			1/2" - 14	30 x 2	11.5	20	30	
- 08 - 30			1/2" - 14	30 x 2	11.5	22	30	
- 10 - 18			5/8" - 14	18 x 1.5	11.5	18	32	
- 10 - 22			5/8" - 14	22 x 1.5	14.5	15	32	
- 10 - 26			5/8" - 14	26 x 1.5	14.5	18	32	

HYDRO – TEC

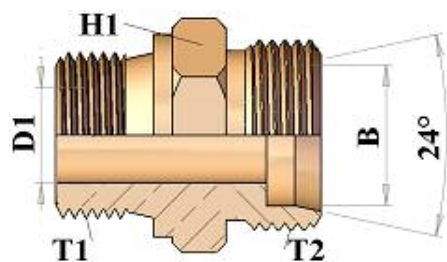

HT500615 STRAIGHT ADAPTOR BSP MALE FLAT / METRIC MALE

نبيل ذكر متري / ذكر BSP وجه مسح

النوع	السعر	العدد	الخطوة		القياسات مم			ملاحظات
			T1 - BSP	T2-METRIC	D1	B	H1	
PART REF.	PRICE	QTY	THREAD		DIMENSION mm			REM.
HT500615- 12 - 22			3/4" - 14	22 x 1.5	14.5	15	32	
- 12 - 24			3/4" - 14	24 x 1.5	17	16	32	
- 12 - 26			3/4" - 14	26 x 1.5	17	18	32	
- 12 - 30			3/4" - 14	30 x 2	17	20	32	
- 12 - 30			3/4" - 14	30 x 2	17	22	32	
- 12 - 36			3/4" - 14	36 x 2	17	25	36	
- 12 - 36			3/4" - 14	36 x 2	17	28	36	
- 16 - 30			1" - 11	30 x 2	22.5	20	41	
- 16 - 30			1" - 11	30 x 2	22.5	22	41	
- 16 - 36			1" - 11	36 x 2	22.5	25	41	
- 16 - 36			1" - 11	36 x 2	22.5	28	41	
- 16 - 42			1" - 11	42 x 2	22.5	30	46	
- 16 - 45			1" - 11	45 x 1.5	22.5	33.5	46	
- 16 - 45			1" - 11	45 x 2	22.5	35	46	
- 20 - 36			1 1/4" - 11	36 x 2	29	25	50	
- 20 - 36			1 1/4" - 11	36 x 2	29	28	50	
- 20 - 42			1 1/4" - 11	42 x 2	29	30	50	
- 20 - 45			1 1/4" - 11	45 x 1.5	29	33.5	50	
- 20 - 45			1 1/4" - 11	45 x 2	29	35	50	
- 20 - 52			1 1/4" - 11	52 x 2	29	38	55	
- 20 - 52			1 1/4" - 11	52 x 2	29	42	55	
- 24 - 45			1 1/2" - 11	45 x 2	33.5	35	55	
- 24 - 52			1 1/2" - 11	52 x 2	33.5	38	55	
- 24 - 52			1 1/2" - 11	52 x 2	33.5	42	55	

HYDRO - TEC

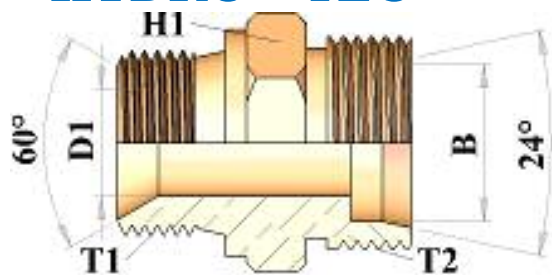

HT500515 STRAIGHT ADAPTOR BSP MALE O'RING / METRIC MALE

نبيل ذكر متري / ذكر BSP مركز سيلية

النوع	السعر	العدد	الخطوة		القياسات مم			ملاحظات
PART REF.	PRICE	QTY	THREAD		DIMENSIONS mm			REM.
			T1 - BSP	T2-METRIC	D1	B	H1	
HT500515- 02 - 10			1/8" - 28	10 x 1	3.5	5	14	
- 02 - 12			1/8" - 28	12 x 1.5	3.5	6	14	
- 04 - 12			1/4" - 19	12 x 1.5	5	6	19	
- 04 - 14			1/4" - 19	14 x 1.5	5	8	19	
- 04 - 16			1/4" - 19	16 x 1.5	5	10	19	
- 04 - 18			1/4" - 19	18 x 1.5	5	12	19	
- 04 - 22			1/4" - 19	22 x 1.5	5	15	22	
- 06 - 12			3/8" - 19	12 x 1.5	8	6	22	
- 06 - 14			3/8" - 19	14 x 1.5	8	8	22	
- 06 - 16			3/8" - 19	16 x 1.5	8	10	22	
- 06 - 18			3/8" - 19	18 x 1.5	8	12	22	
- 06 - 20			3/8" - 19	20 x 1.5	8	12	22	
- 06 - 22			3/8" - 19	22 x 1.5	8	15	22	
- 06 - 24			3/8" - 19	24 x 1.5	8	16	24	
- 08 - 12			1/2" - 14	12 x 1.5	11.5	6	27	
- 08 - 14			1/2" - 14	14 x 1.5	11.5	8	27	
- 08 - 16			1/2" - 14	16 x 1.5	11.5	10	27	
- 08 - 18			1/2" - 14	18 x 1.5	11.5	12	27	
- 08 - 22			1/2" - 14	22 x 1.5	11.5	15	27	
- 08 - 24			1/2" - 14	24 x 1.5	11.5	16	27	
- 08 - 26			1/2" - 14	26 x 1.5	11.5	18	27	
- 08 - 30			1/2" - 14	30 x 2	11.5	20	30	
- 08 - 30			1/2" - 14	30 x 2	11.5	22	30	
- 10 - 18			5/8" - 14	18 x 1.5	11.5	18	32	
- 10 - 22			5/8" - 14	22 x 1.5	14.5	15	32	
- 10 - 26			5/8" - 14	26 x 1.5	14.5	18	32	

HYDRO – TEC

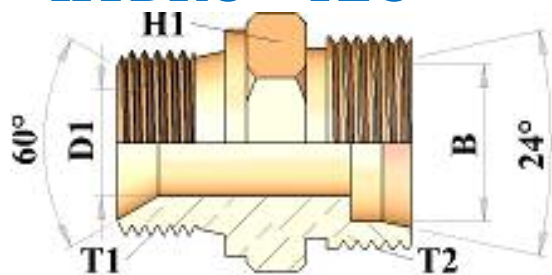

HT500515 STRAIGHT ADAPTOR BSP MALE O'RING / METRIC MALE

نبل ذكر متري / ذكر BSP مركز سيلنة

النوع	السعر	العدد	الخطوة		القياسات مم			ملاحظات
PART REF.	PRICE	QTY	THREAD		DIMENSION mm			REM.
			T1 - BSP	T2-METRIC	D1	B	H1	
HT500515- 12 - 22			3/4" - 14	22 x 1.5	14.5	15	32	
- 12 - 24			3/4" - 14	24 x 1.5	17	16	32	
- 12 - 26			3/4" - 14	26 x 1.5	17	18	32	
- 12 - 30			3/4" - 14	30 x 2	17	20	32	
- 12 - 30			3/4" - 14	30 x 2	17	22	32	
- 12 - 36			3/4" - 14	36 x 2	17	25	36	
- 12 - 36			3/4" - 14	36 x 2	17	28	36	
- 16 - 30			1" - 11	30 x 2	22.5	20	41	
- 16 - 30			1" - 11	30 x 2	22.5	22	41	
- 16 - 36			1" - 11	36 x 2	22.5	25	41	
- 16 - 36			1" - 11	36 x 2	22.5	28	41	
- 16 - 42			1" - 11	42 x 2	22.5	30	46	
- 16 - 45			1" - 11	45 x 1.5	22.5	33.5	46	
- 16 - 45			1" - 11	45 x 2	22.5	35	46	
- 20 - 36			1 1/4" - 11	36 x 2	29	25	50	
- 20 - 36			1 1/4" - 11	36 x 2	29	28	50	
- 20 - 42			1 1/4" - 11	42 x 2	29	30	50	
- 20 - 45			1 1/4" - 11	45 x 1.5	29	33.5	50	
- 20 - 45			1 1/4" - 11	45 x 2	29	35	50	
- 20 - 52			1 1/4" - 11	52 x 2	29	38	55	
- 20 - 52			1 1/4" - 11	52 x 2	29	42	55	
- 24 - 45			1 1/2" - 11	45 x 2	33.5	35	55	
- 24 - 52			1 1/2" - 11	52 x 2	33.5	38	55	
- 24 - 52			1 1/2" - 11	52 x 2	33.5	42	55	

HYDRO – TEC

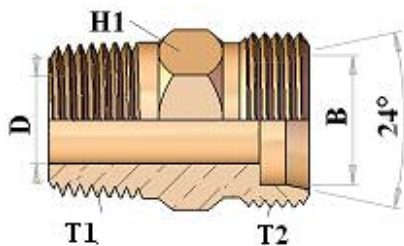

HT500815 STRAIGHT ADAPTOR BSPT MALE FLAT / METRIC MALE

نبيل ذكر متري / ذكر BSPT وجه مسح

النوع	السعر	العدد	الخطوة		القياسات مم			ملاحظات
PART REF.	PRICE	QTY	THREAD		DIMENSIONS mm			REM.
			T1 - BSPT	T2 - METRIC	D1	B	H1	
HT500815- 04 - 12			1/4" - 19	12 x 1.5	5	6	14	
- 04 - 14			1/4" - 19	14 x 1.5	5	8	14	
- 04 - 16			1/4" - 19	16 x 1.5	5	10	17	
- 04 - 18			1/4" - 19	18 x 1.5	5	12	19	
- 04 - 22			1/4" - 19	22 x 1.5	5	15	22	
- 06 - 12			3/8" - 19	12 x 1.5	8	6	19	
- 06 - 14			3/8" - 19	14 x 1.5	8	8	19	
- 06 - 16			3/8" - 19	16 x 1.5	8	10	19	
- 06 - 18			3/8" - 19	18 x 1.5	8	12	19	
- 06 - 20			3/8" - 19	20 x 1.5	8	12	22	
- 06 - 22			3/8" - 19	22 x 1.5	8	15	22	
- 08 - 12			1/2" - 14	12 x 1.5	11.5	6	22	
- 08 - 14			1/2" - 14	14 x 1.5	11.5	8	22	
- 08 - 16			1/2" - 14	16 x 1.5	11.5	10	22	
- 08 - 18			1/2" - 14	18 x 1.5	11.5	12	22	
- 08 - 22			1/2" - 14	22 x 1.5	11.5	15	22	
- 08 - 26			1/2" - 14	26 x 1.5	11.5	18	27	
- 08 - 30			1/2" - 14	30 x 2	11.5	20	30	
- 08 - 30			1/2" - 14	30 x 2	11.5	22	30	
- 12 - 22			3/4" - 14	22 x 1.5	17	15	27	
- 12 - 24			3/4" - 14	24 x 1.5	17	16	27	
- 12 - 26			3/4" - 14	26 x 1.5	17	18	27	
- 12 - 30			3/4" - 14	30 x 2	17	20	30	
- 12 - 30			3/4" - 14	30 x 2	17	22	30	
- 12 - 30			3/4" - 14	30 x 2	17	20	36	
- 12 - 30			3/4" - 14	30 x 2	17	22	35	

HYDRO – TEC

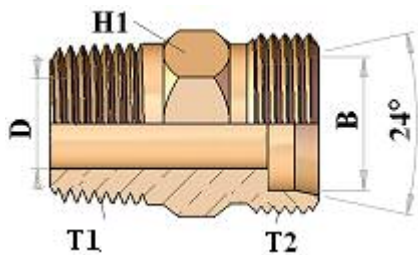

HT500815 STRAIGHT ADAPTOR BSPT MALE FLAT / METRIC MALE

نبيل ذكر متري / ذكر BSPT وجه مسح

النوع	السعر	العدد	الخطوة		القياسات مم			ملاحظات
PART REF.	PRICE	QTY	THREAD		DIMENSIONS mm			REM.
			T1 - BSPT	T2 -METRIC	D1	B	H1	
HT500815- 12 - 36			3/4" - 14	36 x 2	17	25	35	
- 12 - 36			3/4" - 14	36 x 2	17	28	36	
- 16 - 30			1" - 11	30 x 2	22.5	20	36	
- 16 - 30			1" - 11	30 x 2	22.5	22	46	
- 16 - 36			1" - 11	36 x 2	22.5	25	46	
- 16 - 36			1" - 11	36 x 2	22.5	28	46	
- 16 - 42			1" - 11	42 x 2	22.5	30	46	
- 16 - 45			1" - 11	45 x 1.5	22.5	33.5	46	
- 16 - 45			1" - 11	45 x 2	22.5	35	46	
- 20 - 36			1 1/4" - 11	36 x 2	29	25	46	
- 20 - 36			1 1/4" - 11	36 x 2	29	28	46	
- 20 - 42			1 1/4" - 11	42 x 2	29	30	55	
- 20 - 45			1 1/4" - 11	45 x 2	29	35	50	
- 20 - 52			1 1/4" - 11	52 x 2	29	38	55	
- 20 - 52			1 1/4" - 11	52 x 2	29	42	55	
- 24 - 45			1 1/2" - 11	45 x 2	33.5	35	36	
- 24 - 52			1 1/2" - 11	52 x 2	33.5	38	36	
- 24 - 52			1 1/2" - 11	52 x 2	33.5	42	35	

HYDRO – TEC

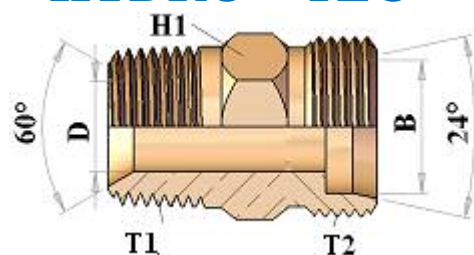

HT500715 STRAIGHT ADAPTOR BSPT MALE / METRIC MALE نبل ذكر متري / ذكر متري

النوع	السعر	العدد	الخطوة		القياسات مم			ملاحظات
PART REF.	PRICE	QTY			DIMENSIONS mm			REM.
			T1 - BSPT	T2 - METRIC	D1	B	H1	
HT500715- 04 - 12			1/4" - 19	12 x 1.5	5	6	14	
- 04 - 14			1/4" - 19	14 x 1.5	5	8	14	
- 04 - 16			1/4" - 19	16 x 1.5	5	10	17	
- 04 - 18			1/4" - 19	18 x 1.5	5	12	19	
- 04 - 22			1/4" - 19	22 x 1.5	5	15	22	
- 06 - 12			3/8" - 19	12 x 1.5	8	6	19	
- 06 - 14			3/8" - 19	14 x 1.5	8	8	19	
- 06 - 16			3/8" - 19	16 x 1.5	8	10	19	
- 06 - 18			3/8" - 19	18 x 1.5	8	12	19	
- 06 - 20			3/8" - 19	20 x 1.5	8	12	22	
- 06 - 22			3/8" - 19	22 x 1.5	8	15	22	
- 08 - 12			1/2" - 14	12 x 1.5	11.5	6	22	
- 08 - 14			1/2" - 14	14 x 1.5	11.5	8	22	
- 08 - 16			1/2" - 14	16 x 1.5	11.5	10	22	
- 08 - 18			1/2" - 14	18 x 1.5	11.5	12	22	
- 08 - 22			1/2" - 14	22 x 1.5	11.5	15	22	
- 08 - 26			1/2" - 14	26 x 1.5	11.5	18	27	
- 08 - 30			1/2" - 14	30 x 2	11.5	20	30	
- 08 - 30			1/2" - 14	30 x 2	11.5	22	30	
- 12 - 22			3/4" - 14	22 x 1.5	17	15	27	
- 12 - 24			3/4" - 14	24 x 1.5	17	16	27	
- 12 - 26			3/4" - 14	26 x 1.5	17	18	27	
- 12 - 30			3/4" - 14	30 x 2	17	20	30	
- 12 - 30			3/4" - 14	30 x 2	17	22	30	
- 12 - 30			3/4" - 14	30 x 2	17	20	36	
- 12 - 30			3/4" - 14	30 x 2	17	22	35	

HYDRO – TEC

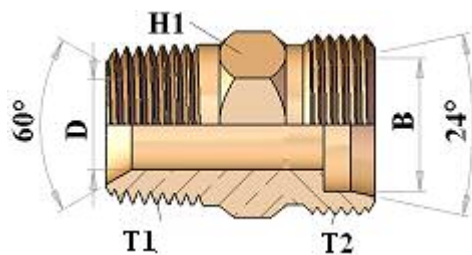

HT500715 STRAIGHT ADAPTOR BSPT MALE / METRIC MALE
نبيل ذكر متري / ذكر BSPT

النوع	السعر	العدد	الخطوة		القياسات مم			ملاحظات
PART REF.	PRICE	QTY	THREAD		DIMENSIONS mm			REM.
			T1 - BSPT	T2 - METRIC	D1	B	H1	
HT500715- 12 - 36			3/4" - 14	36 x 2	17	25	35	
- 12 - 36			3/4" - 14	36 x 2	17	28	36	
- 16 - 30			1" - 11	30 x 2	22.5	20	36	
- 16 - 30			1" - 11	30 x 2	22.5	22	46	
- 16 - 36			1" - 11	36 x 2	22.5	25	46	
- 16 - 36			1" - 11	36 x 2	22.5	28	46	
- 16 - 42			1" - 11	42 x 2	22.5	30	46	
- 16 - 45			1" - 11	45 x 1.5	22.5	33.5	46	
- 16 - 45			1" - 11	45 x 2	22.5	35	46	
- 20 - 36			1 1/4" - 11	36 x 2	29	25	46	
- 20 - 36			1 1/4" - 11	36 x 2	29	28	46	
- 20 - 42			1 1/4" - 11	42 x 2	29	30	55	
- 20 - 45			1 1/4" - 11	45 x 2	29	35	50	
- 20 - 52			1 1/4" - 11	52 x 2	29	38	55	
- 20 - 52			1 1/4" - 11	52 x 2	29	42	55	
- 24 - 45			1 1/2" - 11	45 x 2	33.5	35	36	
- 24 - 52			1 1/2" - 11	52 x 2	33.5	38	36	
- 24 - 52			1 1/2" - 11	52 x 2	33.5	42	35	

HYDRO – TEC

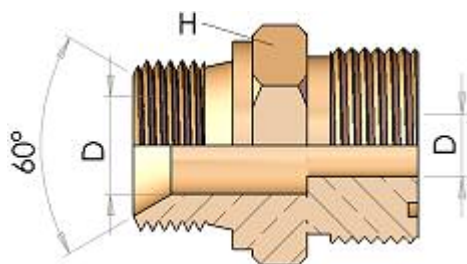

HT500524 STRAIGHT ADAPTOR BSP MALE O'RING / ORFS MALE

نبيل ذكر / ORFS ذكر / BSP مركز سيلة

النوع	السعر	العدد	الخطوة		القياسات مم			ملاحظات
PART REF.	PRICE	QTY	THREAD		DIMENSIONS mm			REM.
			T1 - BSP	T2 - ORFS	D1	D2	H1	
HT500524- 04 - 04			1/4" - 19	9/16" - 18	5	4.4	19	
- 04 - 06			1/4" - 19	11/16" - 16	6.7	6.7	20	
- 06 - 06			3/8" - 19	11/16" - 16	8	6.7	22	
- 06 - 08			3/8" - 19	13/16" - 16	9.6	9.6	22	
- 08 - 08			1/2" - 14	13/16" - 16	11.5	9.6	27	
- 08 - 10			1/2" - 14	1" - 14	12.3	12.3	27	
- 12 - 12			3/4" - 14	1 3/16" - 12	17	15.5	32	
- 16 - 16			1" - 11	1 7/16" - 12	22.5	20.6	41	
- 20 - 20			1".1/4- 11	1.11/16"-12	29	26	50	
- 24 - 24			2" - 12	2" - 12	33.5	32	55	

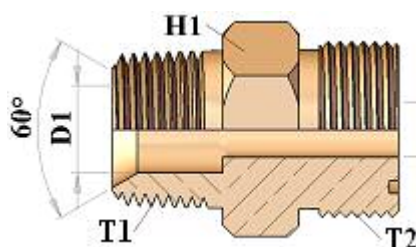

HT500724 STRAIGHT ADAPTOR BSPT MALE / ORFS MALE

نبيل ذكر / ORFS ذكر / BSPT

النوع	السعر	العدد	الخطوة		القياسات مم			ملاحظات
PART REF.	PRICE	QTY	THREAD		DIMENSIONS mm			REM.
			T1 - BSPT	T2 - ORFS	D1	D2	H1	
HT500724- 04 - 04			1/4" - 19	9/16" - 18	5	4.4	16	
- 06 - 06			3/8" - 19	11/16" - 16	8	6.7	20	
- 08 - 08			1/2" - 14	13/16" - 18	11.5	9.6	24	
- 12 - 12			3/4" - 14	1.3/16" - 12	17	15.5	32	
- 16 - 16			1" - 11	1.7/16" - 12	22.5	20.6	38	
- 20 - 20			1.1/4"- 11	1.11/16"-12	29	26	45	
- 24 - 24			1.1/2"- 11	2" - 12	33.5	32	55	

HYDRO – TEC

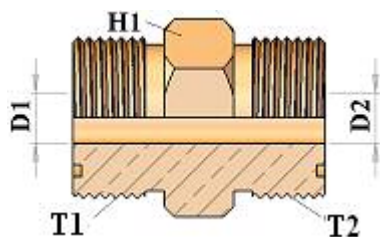

HT502424 STRAIGHT ADAPTOR ORFS MALE
 نبل طرفين ذكر ORFS

النوع	السعر	العدد	الخطوة		القياسات مم			ملاحظات
PART REF.	PRICE	QTY	THREAD		DIMENSIONS mm			REM.
			T2 - ORFS	T2 - ORFS	D1	D2	H1	
HT502424- 04 - 04			9/16" - 18	9/16" - 18	4.4	4.4	16	
- 06 - 06			11/16" - 16	11/16" - 16	6.7	6.7	20	
- 08 - 08			13/16" - 18	13/16" - 18	9.6	9.6	24	
- 12 - 12			1.3/16" - 12	1.3/16" - 12	15.5	15.5	32	
- 16 - 16			1.7/16" - 12	1.7/16" - 12	20.6	20.6	38	
- 20 - 20			1.11/16"-12	1.11/16"-12	26	26	45	
- 24 - 24			2" - 12	2" - 12	32	32	55	

HYDRO – TEC

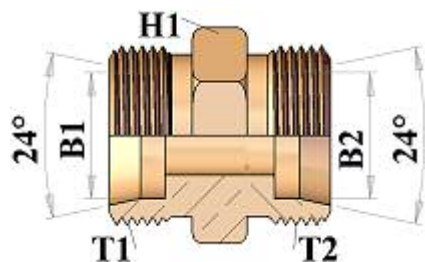

HT501515 STRAIGHT ADAPTOR METRIC MALE LIGHT

نبل طرفين ذكر متري خفيف

النوع	السعر	العدد	الخطوة		القياسات مم			ملاحظات
PART REF.	PRICE	QTY	THREAD		DIMENSIONS mm			REM.
			T1 -METRIC	T2 -METRIC	B1	B2	H1	
HT501515- 08 - 10			8x1	10x1	4	5	12	
- 10 - 10			10 x 1	10 x 1	5	5	12	
- 10 - 12			10 x 1	12 x 1.5	5	6	14	
- 12 - 12			12 x 1.5	12 x 1.5	6	6	14	
- 12 - 14			12 x 1.5	14 x 1.5	6	8	14	
- 12 - 16			12 x 1.5	16 x 1.5	6	10	17	
- 12 - 18			12 x 1.5	18 x 1.5	6	12	19	
- 14 - 14			14 x 1.5	14 x 1.5	8	8	14	
- 14 - 16			14 x 1.5	16 x 1.5	8	10	17	
- 14 - 18			14 x 1.5	18 x 1.5	8	12	19	
- 14 - 22			14 x 1.5	22 x 1.5	8	15	22	
- 16 - 16			16 x 1.5	16 x 1.5	10	10	17	
- 16 - 18			16 x 1.5	18 x 1.5	10	12	19	
- 16 - 22			16 x 1.5	22 x 1.5	10	15	22	
- 18 - 18			18 x 1.5	18 x 1.5	12	12	19	
- 18 - 22			18 x 1.5	22 x 1.5	12	15	22	
- 18 - 26			18 x 1.5	26 x 1.5	12	18	27	
- 22 - 22			22 x 1.5	22 x 1.5	15	15	22	
- 22 - 26			22 x 1.5	26 x 1.5	15	18	27	
- 22 - 30			22 x 1.5	30 x 2	15	22	30	
- 26 - 26			26 x 1.5	26 x 1.5	18	18	27	
- 26 - 30			26 x 1.5	30 x 2	18	22	30	
- 30 - 30			30 x 2	30 x 2	22	22	30	
- 30 - 36			30 x 2	36 x 2	22	28	36	
- 30 - 45			30 x 2	45 x 2	22	35	36	
- 36 - 36			36 x 2	36 x 2	28	28	36	
- 36 - 45			36 x 2	45 x 2	28	35	46	
- 45 - 45			45 x 2	45 x 2	35	35	46	
- 52 - 52			52 x 2	52 x 2	42	42	55	

HYDRO – TEC

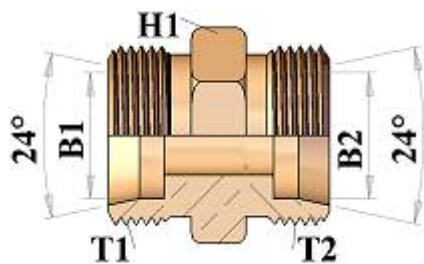

HT501616 STRAIGHT ADAPTOR METRIC MALE HEAVY

نبل طرفين ذكر متري ثقيل

النوع	السعر	العدد	الخطوة		القياسات مم			ملاحظات
PART REF.	PRICE	QTY	THREAD		DIMENSIONS mm			REM.
			T1 -METRIC	T2 -METRIC	B1	B2	H1	
HT501616- 14 - 14			14 x 1.5	14 x 1.5	6	6	14	
- 14 - 16			14 x 1.5	16 x 1.5	6	8	17	
- 14 - 18			14 x 1.5	18 x 1.5	6	10	19	
- 14 - 20			14 x 1.5	20 x 1.5	6	12	22	
- 16 - 16			16 x 1.5	16 x 1.5	8	8	17	
- 16 - 18			16 x 1.5	18 x 1.5	8	10	19	
- 16 - 20			16 x 1.5	20 x 1.5	8	12	22	
- 16 - 24			16 x 1.5	24 x 1.5	10	16	24	
- 18 - 18			18 x 1.5	18 x 1.5	10	10	19	
- 18 - 20			18 x 1.5	20 x 1.5	10	12	22	
- 18 - 22			18 x 1.5	22 x 1.5	10	14	22	
- 18 - 24			18 x 1.5	24 x 1.5	10	16	24	
- 20 - 20			20 x 1.5	20 x 1.5	12	12	22	
- 20 - 22			20 x 1.5	22 x 1.5	12	14	22	
- 20 - 24			20 x 1.5	24 x 1.5	12	16	24	
- 22 - 22			22 x 1.5	22 x 1.5	14	14	22	
- 22 - 24			22 x 1.5	24 x 1.5	14	16	24	
- 22 - 30			22 x 1.5	30 x 2	14	20	30	
- 24 - 24			24 x 1.5	24 x 1.5	16	16	24	
- 30 - 30			30 x 2	30 x 2	20	20	30	
- 30 - 36			30 x 2	36 x 2	20	25	36	
- 36 - 36			36 x 2	36 x 2	25	25	36	
- 36 - 42			36 x 2	42 x 2	25	30	46	
- 42 - 42			42 x 2	42 x 2	30	30	46	
- 42 - 52			42 x 2	52 x 2	30	38	55	
- 52 - 52			52 x 2	52 x 2	38	38	55	

HYDRO – TEC

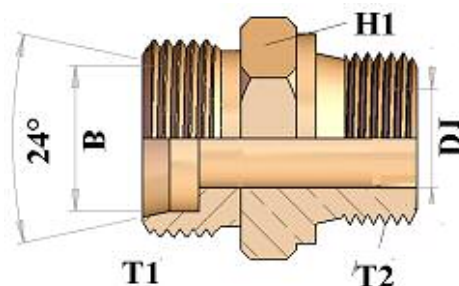

HT501517 STRAIGHT ADAPTOR METRIC MALE LIGHT / O'RING MALE

نبيل ذكر متري خفيف / متري تثبيت

النوع	السعر	العدد	الخطوة		القياسات مم			ملاحظات
PART REF.	PRICE	QTY	THREAD		DIMENSIONS mm			REM.
			T1 - METRIC	T2 - METRIC	B1	D1	H1	
HT501517- 08 - 10			08 x 1	10 x 1	4		12	
- 10 - 10			10 x 1	10 x 1	5		14	
- 12 - 10			12 x 1.5	10 x 1	6		12	
- 14 - 10			14 x 1.5	10 x 1	8		14	
- 12 - 12			12 x 1.5	12 x 1.5	6		14	
- 14 - 12			14 x 1.5	12 x 1.5	8		14	
- 16 - 12			16 x 1.5	12 x 1.5	10		17	
- 18 - 12			18 x 1.5	12 x 1.5	12		19	
- 22 - 12			22 x 1.5	12 x 1.5	15		22	
- 12 - 14			12 x 1.5	14 x 1.5	6		17	
- 14 - 14			14 x 1.5	14 x 1.5	8		17	
- 16 - 14			16 x 1.5	14 x 1.5	10		17	
- 18 - 14			18 x 1.5	14 x 1.5	12		19	
- 22 - 14			22 x 1.5	14 x 1.5	15		22	
- 12 - 16			12 x 1.5	16 x 1.5	6		19	
- 14 - 16			14 x 1.5	16 x 1.5	8		19	
- 16 - 16			16 x 1.5	16 x 1.5	10		19	
- 18 - 16			18 x 1.5	16 x 1.5	12		19	
- 22 - 16			22 x 1.5	16 x 1.5	15		22	
- 12 - 18			12 x 1.5	18 x 1.5	6		22	
- 14 - 18			14 x 1.5	18 x 1.5	8		22	
- 16 - 18			16 x 1.5	18 x 1.5	10		22	
- 18 - 18			18 x 1.5	18 x 1.5	12		22	
- 22 - 18			22 x 1.5	18 x 1.5	15		22	
- 26 - 18			26 x 1.5	18 x 1.5	18		27	

HYDRO – TEC

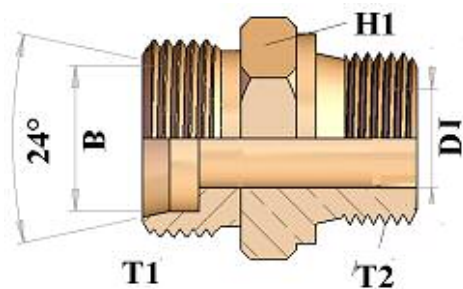

HT501517 STRAIGHT ADAPTOR METRIC MALE LIGHT / O'RING MALE

نبيل ذكر متري خفيف / متري تثبيت

النوع	السعر	العدد	الخطوة		القياسات مم			ملاحظات
PART REF.	PRICE	QTY	THREAD		DIMENSIONS mm			REM.
			T1 - METRIC	T2 - METRIC	B1	D1	H1	
HT501517- 22 - 20			22 x 1.5	20 x 1.5	15		27	
- 16 - 22			16 x 1.5	22 x 1.5	10		27	
- 18 - 22			18 x 1.5	22 x 1.5	12		27	
- 22 - 22			22 x 1.5	22 x 1.5	15		27	
- 26 - 22			26 x 1.5	22 x 1.5	18		27	
- 30 - 22			30x 2	22 x 1.5	22		30	
- 22 - 24			22 x 1.5	24 x 1.5	15		27	
- 26 - 24			26 x 1.5	24 x 1.5	18		27	
- 26 - 26			26 x 1.5	26 x 1.5	18		32	
- 30 - 26			30 x 2	26 x 1.5	22		32	
- 30 - 27			30 x 2	27 x 2	22		32	
- 30 - 30			30 x 2	30 x 2	22		36	
- 36 - 30			36 x 2	30 x 2	28		36	
- 30 - 33			30 x 2	33 x 2	22		36	
- 36 - 33			36 x 2	33 x 2	28		36	
- 45 - 33			45 x 2	33 x 2	35		46	
- 36 - 42			36 x 2	42 x 2	28		46	
- 45 - 42			45 x 2	42 x 2	35		46	
- 52 - 42			52 x 2	42 x 2	42		55	
- 36 - 48			36 x 2	48 x 2	28		55	
- 45 - 48			45 x 2	48 x 2	35		55	
- 52 - 48			52 x 2	48 x 2	42		55	

HYDRO – TEC

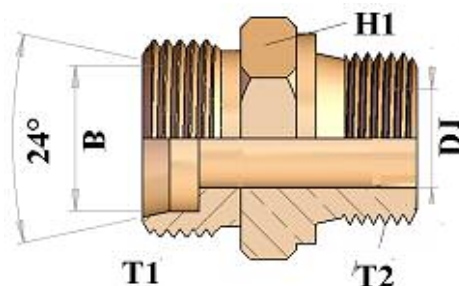

HT501617 STRAIGHT ADAPTOR METRIC MALE HEAVY / O'RING MALE

نبل ذكر متري ثقيل / متري تثبيت

النوع	السعر	العدد	الخطوة		القياسات مم			ملاحظات
PART REF.	PRICE	QTY	THREAD		DIMENSIONS mm			REM.
			T1 - METRIC	T2 - METRIC	B1	D1	H1	
HT501617- 14 - 12			14 x 1.5	12 x 1.5	6		17	
- 16 - 12			16 x 1.5	12 x 1.5	8		17	
- 14 - 14			14 x 1.5	14 x 1.5	6		17	
- 16 - 14			16 x 1.5	14 x 1.5	8		17	
- 18 - 14			18 x 1.5	10 x 1.5	10		19	
- 14 - 16			14 x 1.5	16 x 1.5	6		19	
- 16 - 16			16 x 1.5	16 x 1.5	8		19	
- 18 - 16			18 x 1.5	16 x 1.5	10		19	
- 20 - 16			20 x 1.5	16 x 1.5	12		22	
- 24 - 16			24 x 1.5	16 x 1.5	16		24	
- 16 - 18			16 x 1.5	18 x 1.5	8		22	
- 18 - 18			18 x 1.5	18 x 1.5	10		22	
- 20 - 18			20 x 1.5	18 x 1.5	12		24	
- 22 - 18			22 x 1.5	18 x 1.5	14		24	
- 24 - 18			24 x 1.5	18 x 1.5	16		24	
-18 - 20			18 x 1.5	20 x 1.5	10		27	
- 20 - 20			20 x 1.5	20 x 1.5	12		27	
- 20 - 22			20 x 1.5	22 x 1.5	12		27	
- 24 - 22			24 x 1.5	22 x 1.5	16		27	
- 30 - 22			30 x 1.5	22 x 1.5	20		30	
- 24 - 24			24 x 1.5	24 x 1.5	16		30	
- 36 - 30			36 x 2	30 x 2	25		36	
- 30 - 33			30 x 2	33 x 2	20		36	
- 36 - 33			36 x 2	33 x 2	25		36	
- 36 - 42			36 x 2	42 x 2	25		46	
- 52 - 42			52 x 2	42 x 2	38		55	
- 42 - 48			42 x 2	48 x 2	30		55	
- 52 - 48			52 x 2	48 x 2	38		55	

HYDRO - TEC

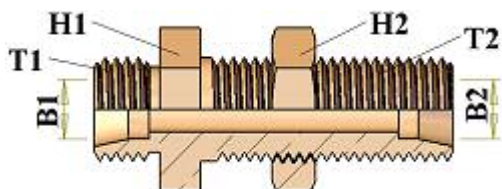

HT501512 STRAIGHT BULKHEAD ADAPTOR METRIC MALE

نبيل ذكر متري مع عزقة كترول / ذكر متري

النوع	السعر	العدد	الخطوة		القياسات مم				ملاحظات
PART REF.	PRICE	QTY	THREAD		DIMENSIONS mm				REM.
			T1 - METRIC	T2 - METRIC	B1	B2	H1	H2	
HT501512- 12 - 12			12 x 1.5	12 x 1.5	6	6	14	14	
- 14 - 14			14 x 1.5	14 x 1.5	8	8	17	17	
- 16 - 16			16 x 1.5	16 x 1.5	10	10	19	19	
- 16 - 18			16 x 1.5	18 x 1.5	10	12	22	22	
- 18 - 16			18 x 1.5	16 x 1.5	12	10	19	19	
- 18 - 18			18 x 1.5	18 x 1.5	12	12	22	22	
- 22 - 18			22 x 1.5	18 x 1.5	15	12	22	22	
- 22 - 22			22 x 1.5	22 x 1.5	15	15	27	27	
- 24 - 24			24 x 1.5	24 x 1.5	16	16	30	30	
- 26 - 26			26 x 1.5	26 x 1.5	18	18	32	32	
- 30 - 30			30 x 2	30 x 2	20	20	36	36	
- 30 - 30			30 x 2	30 x 2	22	22	36	36	

METRIC LOCK NUT

عزقة كترول متري

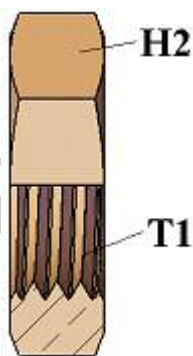

	السعر	العدد	شرار - سن	القياسات مم	ملاحظات
PART REF.	PRICE	QTY	THREAD	DIMENSIONS	REM.
			T	H2	
M-L-N - 12			M 12x1.5	14	
- 14			M 14x1.5	17	
- 16			M 16x1.5	19	
- 18			M 18x1.5	22	
- 20			M 20x1.5	24	
- 22			M 22x1.5	27	
- 24			M 24x1.5	30	
- 26			M 26x1.5	32	
- 30			M 30x2	36	

HYDRO – TEC

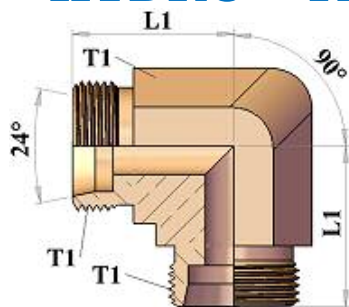

HT561515 90 ELBOW ADAPTOR METRIC MALE

نبيل كوع ذكرين متري

النوع	السعر	العدد	الخطوة	القياسات مم		ملاحظات	
PART REF.	PRICE	QTY	THREAD		DIMENSIONS mm		REM.
			T1 - METRIC		L1	H1	
HT561515- 12 - 12			12 x 1.5		19	12	
- 14 - 14			14 x 1.5		20	14	
- 16 - 16			16 x 1.5		22	16	
- 18 - 18			18 x 1.5		25	18	
- 22 - 22			22 x 1.5		28	22	
- 24 - 24			24 x 1.5		31	24	
- 26 - 26			26 x 1.5		33	26	
- 30 - 30			30 x 2		35	30	
- 36 - 36			36 x 2		39	36	B25
- 36 - 36			36 x 2		39	42	B28
- 42 - 42			42 x 2		46	45	
- 45 - 45			45 x 2		47	45	
- 52 - 52			45 x 2		55	60	

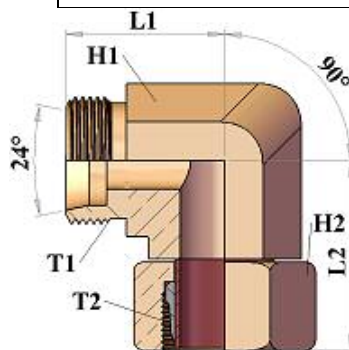

HT581515 90 ELBOW ADAPTOR METRIC MALE / FEMALE

نبيل كوع متحرك متري / ذكر متري

النوع	السعر	العدد	الخطوة		القياسات مم				ملاحظات
PART REF.	PRICE	QTY	THREAD		DIMENSIONS mm				REM.
			T1 -METRIC	T2 -METRIC	L1	L2	H1	H2	
HT581515- 12 - 12			12 x 1.5	12 x 1.5	19	25	12	14	
- 14 - 14			14 x 1.5	14 x 1.5	20	27	14	17	
- 16 - 16			16 x 1.5	16 x 1.5	22	27	16	19	
- 18 - 18			18 x 1.5	18 x 1.5	25	28	18	22	
- 22 - 22			22 x 1.5	22 x 1.5	28	32	22	27	
- 24 - 24			24 x 1.5	24 x 1.5	31	35	24	30	
- 26 - 26			26 x 1.5	26 x 1.5	33	37	26	32	
- 30 - 30			30 x 2	30 x 2	35	37	30	36	
- 36 - 36			36 x 2	36 x 2	39	55	36	41	B25
- 36 - 36			36 x 2	36 x 2	39	55	36	41	B28
- 42 - 42			42 x 2	42 x 2	46	63	42	46	
- 45 - 45			45 x 2	45 x 2	47	62	45	50	
- 52 - 52			45 x 2	45 x 2	55	65	45	60	

HYDRO - TEC

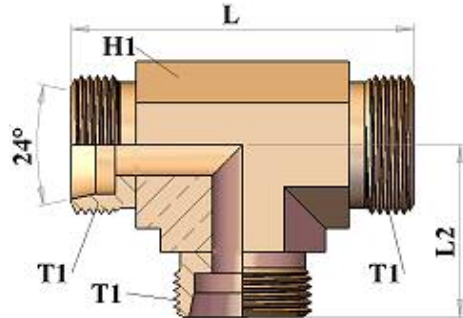

HT701515 UNION TEE ADAPTOR METRIC MALE

مثلث ٣ أطراف ذكر سن متري

النوع	السعر	العدد	الخطوة	القياسات مم			ملاحظات	
PART REF.	PRICE	QTY	THREAD		DIMENSIONS mm			REM.
			T1 - METRIC		L	L1	H1	
HT701515- 12 - 12			12 x 1.5		38	19	12	
- 14 - 14			14 x 1.5		40	20	14	
- 16 - 16			16 x 1.5		44	22	16	
- 18 - 18			18 x 1.5		50	25	18	
- 22 - 22			22 x 1.5		56	28	20	
- 24 - 24			24 x 1.5		61	31	22	
- 26 - 26			26 x 1.5		66	33	24	
- 30 - 30			30 x 2		70	35	26	
- 36 - 36			36 x 2		78	39	30	B25
- 36 - 36			36 x 2		78	39	36	B28
- 42 - 42			42 x 2		92	46	42	
- 45 - 45			45 x 2		94	47	45	
- 52 - 52			45 x 2		98	55	60	

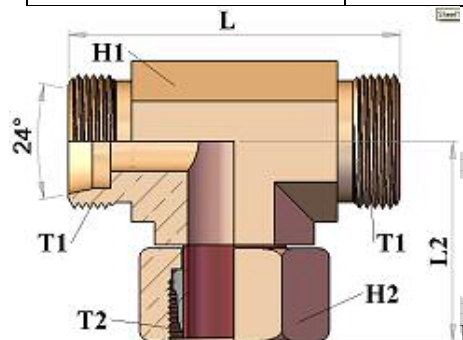

HT711515 UNION TEE ADAPTOR METRIC MALE / FEMALE

مثلث سن متري طرفين ذكر مع وسط متحرك

النوع	السعر	العدد	الخطوة		القياسات مم				ملاحظات
PART REF.	PRICE	QTY	THREAD		DIMENSIONS mm				REM.
			T1 -METRIC	T2 -METRIC	L	L2	H1	H2	
HT711515- 12 - 12			12 x 1.5	12 x 1.5	38	25	12	14	
- 14 - 14			14 x 1.5	14 x 1.5	40	27	14	17	
- 16 - 16			16 x 1.5	16 x 1.5	44	27	16	19	
- 18 - 18			18 x 1.5	18 x 1.5	50	28	18	22	
- 22 - 22			22 x 1.5	22 x 1.5	56	32	20	24	
- 24 - 24			24 x 1.5	24 x 1.5	61	35	22	27	
- 26 - 26			26 x 1.5	26 x 1.5	66	37	24	30	
- 30 - 30			30 x 2	30 x 2	70	37	26	32	
- 36 - 36			36 x 2	36 x 2	78	55	30	36	B25
- 36 - 36			36 x 2	36 x 2	78	55	36	41	B28
- 42 - 42			42 x 2	42 x 2	92	63	42	46	
- 45 - 45			45 x 2	45 x 2	94	62	45	50	
- 52 - 52			45 x 2	45 x 2	98	66	55	60	

HYDRO – TEC

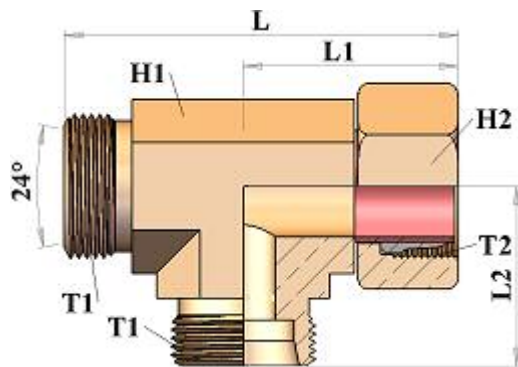

HT721515 RUN TEE ADAPTOR METRIC MALE / METRIC FEMALE

مثلث سن متري طرف ووسط ذكر مع طرف متحرك

النوع	السعر	العدد	الخطوة		القياسات مم					ملاحظات
PART REF.	PRICE	QTY	THREAD		DIMENSIONS mm					REM.
			T1-METRIC	T2-METRIC	L	L1	L2	H1	H2	
HT721515- 12 - 12			12 x 1.5	12 x 1.5	44	25	19	12	14	
- 14 - 14			14 x 1.5	14 x 1.5	47	27	20	14	17	
- 16 - 16			16 x 1.5	16 x 1.5	49	27	22	16	19	
- 18 - 18			18 x 1.5	18 x 1.5	53	28	25	18	22	
- 22 - 22			22 x 1.5	22 x 1.5	60	32	28	20	24	
- 24 - 24			24 x 1.5	24 x 1.5	66	35	31	22	27	
- 26 - 26			26 x 1.5	26 x 1.5	70	37	33	24	30	
- 30 - 30			30 x 2	30 x 2	72	37	35	26	32	
- 36 - 36			36 x 2	36 x 2	94	55	39	30	36	
- 36 - 36			36 x 2	36 x 2	94	55	39	36	41	
- 42 - 42			42 x 2	42 x 2	109	63	46	42	46	
- 45 - 45			45 x 2	45 x 2	109	62	47	46	50	
- 52 - 52			45 x 2	45 x 2	118	66	50	55	60	

HYDRO – TEC

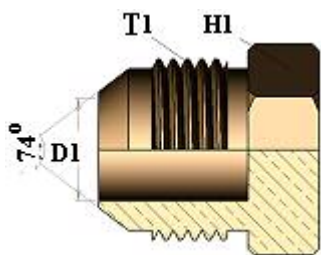

HT402500 JIC MALE PLUG

سدة ذكر سن JIC

PART REF.	السعر	العدد	الخطوة	القياسات مم		ملاحظات
	PRICE	QTY	THREAD	DIMENSIONS mm		REM.
			T1 - JIC	D1	H1	
HT402500 - 04			7/16" - 20	4	12	
- 05			1/2" - 20	5	14	
- 06			9/16" - 18	6.5	16	
- 08			3/4" - 16	9.5	22	
- 10			7/8" - 14	12	24	
- 12			1 1/16" -12	15	30	
- 16			1 5/16" -12	21	35	
- 20			1 5/8" -12	26.5	43	
- 24			1 7/8" -12	32	50	

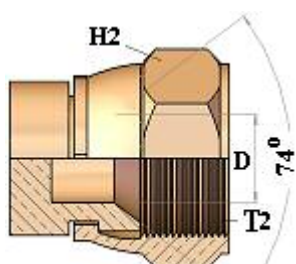

HT412500 FEMALE PLUG JIC

سدة متحركة سن JIC

PART REF.	السعر	العدد	الخطوة	القياسات مم		ملاحظات
	PRICE	QTY	THREAD	DIMENSIONS mm		REM.
			T2 - JIC	D	H2	
HT412500 - 04			7/16" - 20	4	16	
- 05			1/2" - 20	5	16	
- 06			9/16" - 18	6.5	19	
- 08			3/4" - 16	9.5	22	
- 10			7/8" - 14	12	27	
- 12			1 1/16" -12	15	32	
- 16			1 5/16" -12	21	38	
- 20			1 5/8" -12	26.5	50	
- 24			1 7/8" -12	32	55	

HYDRO – TEC

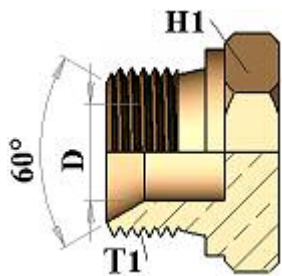

HT400500 MALE PLUG BSP O'RING

سدة ذكر سن BSP مركز سيطة

النوع	السعر	العدد	الخطوة	القياسات مم		ملاحظات
PART REF.	PRICE	QTY	THREAD	DIMENSIONS mm		REM.
				D	H1	
HT400500 - 02			1/8" - 28	3.5	14	
- 04			1/4" - 19	5	19	
- 06			3/8" - 19	8	22	
- 08			1/2" - 14	11.5	27	
- 10			5/8" - 14	14.5	30	
- 12			3/4" - 14	17	32	
- 16			1" - 11	22.5	41	
- 20			1".1/4- 11	29	50	
- 24			1".1/2- 11	33.5	55	

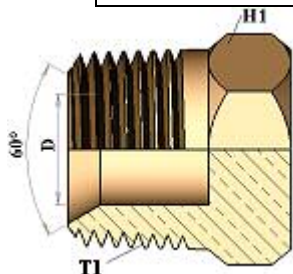

HT400700 BSPT PLUG

سدة ذكر سن BSPT

النوع	السعر	العدد	الخطوة	القياسات مم		ملاحظات
PART REF.	PRICE	QTY	THREAD	DIMENSIONS mm		REM.
				D	H1	
HT400700 - 02			1/8" - 28	3.5	10	
- 04			1/4" - 19	5	12	
- 06			3/8" - 19	8	15	
- 08			1/2" - 14	11.5	19	
- 12			3/4" - 14	17	24	
- 16			1" - 11	22.5	30	
- 20			1".1/4- 11	29	36	
- 24			1".1/2- 11	33.5	45	
- 32			2" - 11	44	50	

HYDRO – TEC

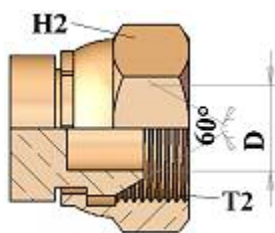

HT410500 FEMALE PLUG BSP

سدة متحركة سن BSP

النوع	السعر	العدد	الخطوة	القياسات مم		ملاحظات
PART REF.	PRICE	QTY	THREAD	DIMENSIONS mm		REM.
				D	H2	
HT410500 - 02			1/8" - 28	3.5	14	
- 04			1/4" - 19	5	19	
- 06			3/8" - 19	8	22	
- 08			1/2" - 14	11.5	27	
- 10			5/8" - 14	14.5	30	
- 12			3/4" - 14	17	32	
- 16			1" - 11	22.5	41	
- 20			1".1/4- 11	29	50	
- 24			1".1/2- 11	33.5	55	

HYDRO – TEC

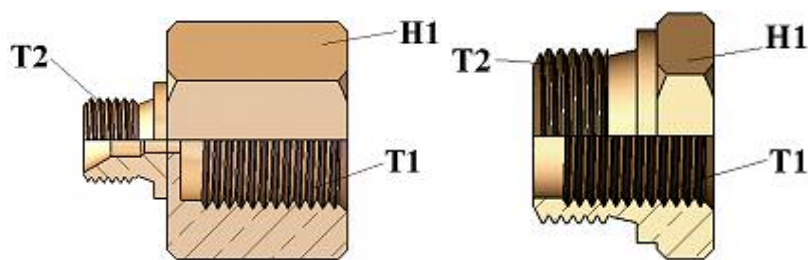

HT410505 BSP TRANSITION

تحويله BSP

PART REF.	السعر	العدد	شراير - سن		القياسات مم	ملاحظات
	PRICE	QTY	THREAD		DIMENSIONS mm	REM.
			T1 - BSP	T2 -BSP	H1	
HT410505-02-04			1/8" - 28	1/4" - 19	17	
-04-02			1/4" - 19	1/8" - 28	17	
-04-06			1/4" - 19	3/8" - 19	22	
04-08			1/4" - 19	1/2" - 14	27	
-06-02			3/8" - 19	1/8" - 28	22	
-06-04			3/8" - 19	1/4" - 19	22	
-06-08			3/8" - 19	1/2" - 14	27	
-08-02			1/2" - 14	1/8" - 28	27	
-08-04			1/2" - 14	1/4" - 19	27	
-08-06			1/2" - 14	3/8" - 19	27	
-08-12			1/2" - 14	3/4" - 14	32	
-12-04			3/4" - 14	1/4" - 19	32	
-12-06			3/4" - 14	3/8" - 19	32	
-12-08			3/4" - 14	1/2" - 14	32	
-16-08			1" - 11	1/2" - 14	41	
-16-12			1" - 11	3/4" - 14	41	
-16-20			1" - 11	1.1/4" - 11	50	
-20-12			1.1/4" - 11	3/4" - 14	50	
-20-16			1.1/4" - 11	1" - 11	50	
-20-24			1.1/4" - 11	1.1/2" - 11	55	
-24-16			1.1/2" - 11	1" - 11	55	
-24-20			1.1/2" - 11	1.1/4" - 11	55	
-32-24			2" - 11	1.1/2" - 11	70	

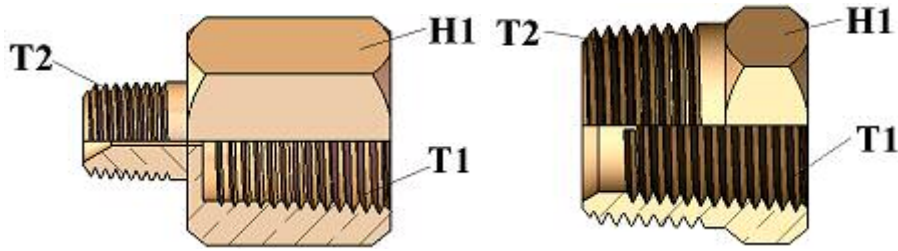

HT410707 BSPT TRANSITION

تحويله BSPT

PART REF.	السعر	العدد	شراير - سن		القياسات مم	ملاحظات
	PRICE	QTY	THREAD		DIMENSIONS mm	REM.
			T1 - BSP	T2 -BSP	H1	
HT410707-02-04			1/8" - 28	1/4" - 19	15	
-04-02			1/4" - 19	1/8" - 28	17	
-04-06			1/4" - 19	3/8" - 19	19	
04-08			1/4" - 19	1/2" - 14	22	
-06-02			3/8" - 19	1/8" - 28	19	
-06-04			3/8" - 19	1/4" - 19	19	
-06-08			3/8" - 19	1/2" - 14	22	
-08-02			1/2" - 14	1/8" - 28	22	
-08-04			1/2" - 14	1/4" - 19	22	
-08-06			1/2" - 14	3/8" - 19	22	
-08-12			1/2" - 14	3/4" - 14	27	
-12-04			3/4" - 14	1/4" - 19	32	
-12-06			3/4" - 14	3/8" - 19	32	
-12-08			3/4" - 14	1/2" - 14	32	
-16-08			1" - 11	1/2" - 14	41	
-16-12			1" - 11	3/4" - 14	41	
-16-20			1" - 11	1.1/4"- 11	46	
-20-12			1.1/4"- 11	3/4" - 14	46	
-20-16			1.1/4"- 11	1" - 11	46	
-20-24			1.1/4"- 11	1.1/2"- 11	50	
-24-16			1.1/2"- 11	1" - 11	55	
-24-20			1.1/2"- 11	1.1/4"- 11	55	
-32-24			2" - 11	1.1/2"- 11	70	

HYDRO – TEC

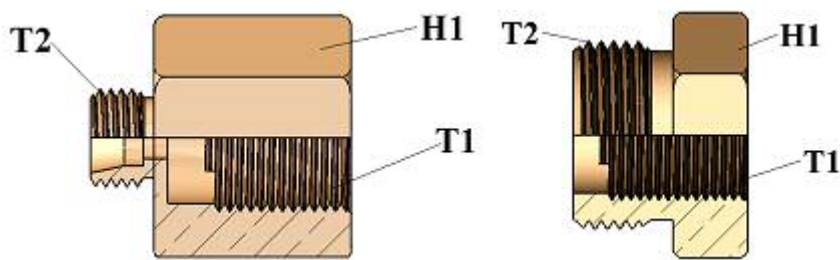

HT411515 METRIC TRANSITION

تحويله متري

	السعر	العدد	شرار - سن		القياسات مم	ملاحظات
PART REF.	PRICE	QTY	THREAD		DIMENSIONS mm	REM.
			T1 - METRIC	T2 - METRIC		
HT411515-16-10			M 16x1.5	M 10x1	19	
-18-12			M 18x1.5	M 12x1.5	22	
-18-14			M 18x1.5	M 14x1.5	22	
-18-22			M 18x1.5	M 22x1.5	27	
-20-18			M 20x1.5	M 18x1.5	27	
-22-12			M 22x1.5	M 12x1.5	27	
-22-14			M 22x1.5	M 14x1.5	27	
-22-16			M 22x1.5	M 16x1.5	27	
-22-18			M 22x1.5	M 18x1.5	27	
-26-22			M 26x1.5	M 22x1.5	32	

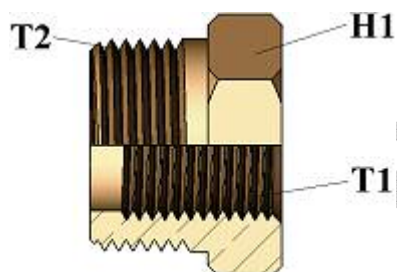

HT410515 IN BSP OUT METRIC TRANSITION

تحويله داخلي BSP خارجي متري

	السعر	العدد	شرار - سن		القياسات مم	ملاحظات
PART REF.	PRICE	QTY	THREAD		DIMENSIONS mm	REM.
			T1 - BSP	T2 - METRIC		
HT410515-02-16			1/8" - 28	M 16x1.5	19	
-02-18			1/8" - 28	M 18x1.5	22	
-02-22			1/8" - 28	M 22x1.5	27	
-04-18			1/4" - 19	M 18x1.5	22	
04-22			1/4" - 19	M 22x1.5	27	
-06-22			3/8" - 19	M 22x1.5	27	
-08-26			1/2" - 14	M 26x1.5	32	

HYDRO – TEC

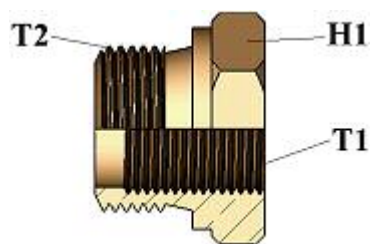

HT411505 IN METRIC OUT BSP TRANSITION

تحويله داخلي متري خارجي BSP

	السعر	العدد	شرا - سن		القياسات مم	ملاحظات
PART REF.	PRICE	QTY	THREAD		DIMENSIONS mm	REM.
			T1 - METRIC	T2 - BSP	H1	
HT411505-12-06			M 12x1.5	3/8" - 19	22	
-12-08			M 12x1.5	1/2" - 14	27	
-14-08			M 14x1.5	1/2" - 14	27	
-16-08			M 16x1.5	1/2" - 14	27	
-18-12			M 18x1.5	3/4" - 14	32	
-20-12			M 20x1.5	3/4" - 14	32	
-22-12			M 22x1.5	3/4" - 14	32	

HYDRO – TEC

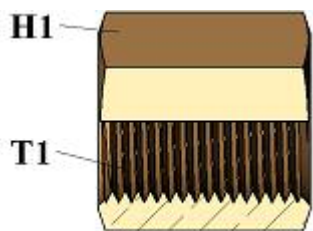

HT-FNB BSP FIXED NUT

عزقة نافذة BSP

	السعر	العدد	شرار - سن	القياسات مم	ملاحظات
PART REF.	PRICE	QTY	THREAD	DIMENSIONS mm	REM.
			T1	H1	
HT-FNB-02			1/8" - 28	14	
-04			1/4" - 19	19	
-06			3/8" - 19	22	
-08			1/2" - 14	27	
-10			5/8" - 14	30	
-12			3/4" - 14	32	
-16			1" - 11	41	
-20			1.1/4" - 11	50	
-24			1.1/2" - 11	55	
-32			2" - 11	60	

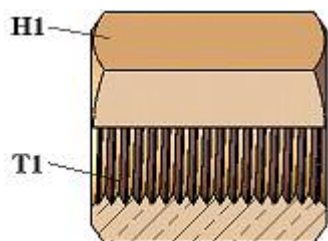

HT-FNM METRIC FIXED NUT

عزقة نافذة متري

	السعر	العدد	شرار - سن	القياسات مم	ملاحظات
PART REF.	PRICE	QTY	THREAD	DIMENSIONS mm	REM.
			T1	H1	
HT-FNM-12			M 12x1.5	14	
-14			M 14x1.5	17	
-16			M 16x1.5	19	
-18			M 18x1.5	22	
-22			M 22x1.5	27	
-26			M 26x1.5	32	

HYDRO – TEC

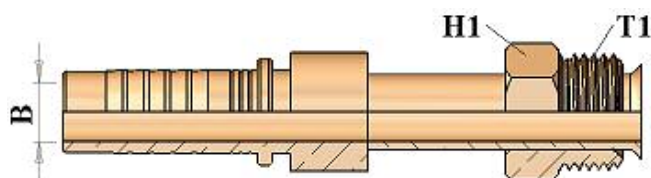

JIC MF-ST
مستقيم MF سن أمريكي

النوع	السعر	العدد	الخطوة	القياسات مم		ملاحظات
PART REF.	PRICE	QTY	THREAD	DIMENSIONS mm		REM.
				B	H1	
MF-04-04 ST			7/16" - 20	4	14	
05-05 ST			1/2" - 20	5	17	
06-07 ST			5/8" - 18	7	17	
08-08 ST			3/4" - 16	9.5	19	
10-10 ST			7/8" - 14	12.5	22	

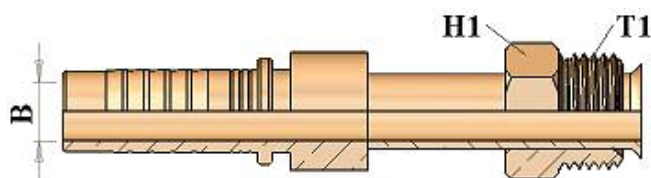

METRIC MF-ST
مستقيم MF سن متري

النوع	السعر	العدد	الخطوة	القياسات مم		ملاحظات
PART REF.	PRICE	QTY	THREAD	DIMENSIONS mm		REM.
				B	H1	
MF-05-14 ST			M14x1.5	5	17	
06-14 ST			M14x1.5	7	17	
06-16 ST			M16x1.5	7	19	

HYDRO – TEC

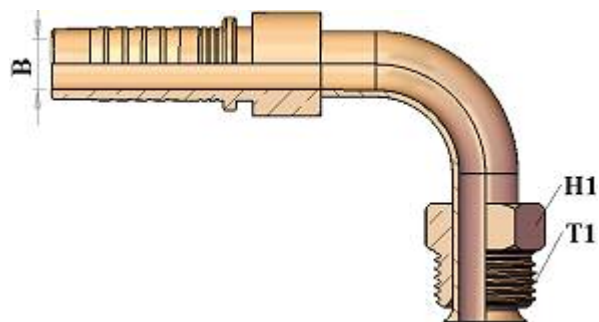

JIC MF-90
كوع MF سن أمريكي

النوع	السعر	العدد	الخطوة	القياسات مم		ملاحظات
PART REF.	PRICE	QTY	THREAD	DIMENSIONS mm		REM.
				B	H1	
MF-04-04 90			7/16" - 20	4	14	
05-05 90			1/2" - 20	5	17	
06-07 90			5/8" - 18	7	17	
08-08 90			3/4" - 16	9.5	19	
10-10 90			7/8" - 14	12.5	22	

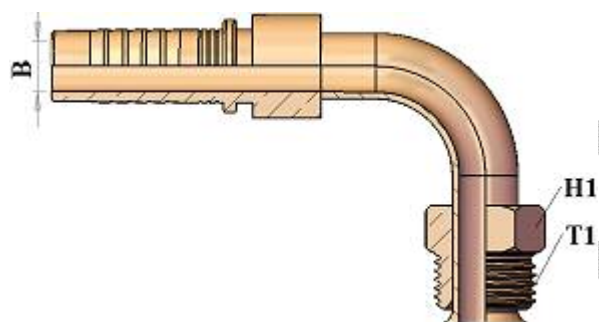

METRIC MF-90
كوع MF سن متري

النوع	السعر	العدد	الخطوة	القياسات مم		ملاحظات
PART REF.	PRICE	QTY	THREAD	DIMENSIONS mm		REM.
				B	H1	
MF-05-14 90			M14x1.5	5	17	
06-14 90			M14x1.5	7	17	
06-16 90			M16x1.5	7	19	

HYDRO – TEC

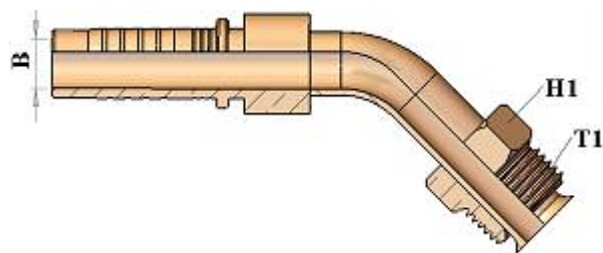

JIC MF- 45
نصف كوع MF سن أمريكي

النوع	السعر	العدد	الخطوة	القياسات مم		ملاحظات
PART REF.	PRICE	QTY	THREAD	DIMENSIONS mm		REM.
				B	H1	
MF-04-04 45			7/16" - 20	4	14	
05-05 45			1/2" - 20	5	17	
06-07 45			5/8" - 18	7	17	
08-08 45			3/4" - 16	9.5	19	
10-10 45			7/8" - 14	12.5	22	

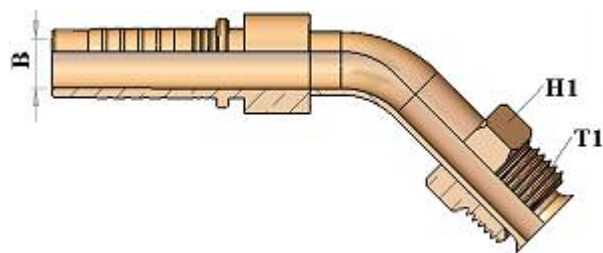

METRIC MF-45
نصف كوع MF سن متري

النوع	السعر	العدد	الخطوة	القياسات مم		ملاحظات
PART REF.	PRICE	QTY	THREAD	DIMENSIONS mm		REM.
				B	H1	
MF-05-14 45			M14x1.5	5	17	
06-14 45			M14x1.5	7	17	
06-16 45			M16x1.5	7	19	

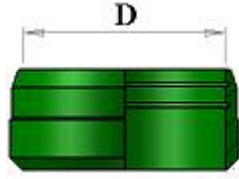

HT421500 METRIC PIPE RING
كونيك متري



AMERICAN BRASS SLEEVE BARREL
حبسة نحاس أمريكي

	السعر	العدد	القياسات مم	ملاحظات
PART REF.	PRICE	QTY	DIMENSIONS mm	REM.
			D	
HT421500-04			4	
- 06			6	
- 08			8	
- 10			10	
- 12			12	
- 14			14	
- 15			15	
- 16			16	
- 18			18	
- 20			20	
- 22			22	
- 25			25	
- 28			28	
- 30			30	
- 35			35	
- 38			38	
- 42			42	

	السعر	العدد	ملاحظات
PART REF.	PRICE	QTY	REM.
A-P-S- 03			
- 04			
- 05			
- 06			
- 08			
- 10			
- 12			
- 15			
- 16			

FILLING POLYAMIDE TUBE

حشوه خرطوم بلاستيك



	السعر	العدد	ملاحظات
PART REF.	PRICE	QTY	REM.
F-P-T-- 04			
- 06			
- 08			
- 10			
- 12			
- 15			



BRASS WASHER

رنديلة نحاس

	السعر	العدد	ملاحظات
PART REF.	PRICE	QTY	REM.
B-W- 05			
- 06			
- 07			
- 08			
- 10			
- 11			
- 12			
- 13			
- 14			
- 16			
- 17			
- 18			
- 19			
- 20			
- 21			
- 22			
- 24			
- 26			
- 28			
- 30			
- 32			
- 34			

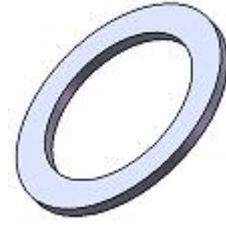

ALUMINUM WASHER

رنديلة ألومنيوم

	السعر	العدد	ملاحظات
PART REF.	PRICE	QTY	REM.
AL-W- 05			
- 06			
-			
- 08			
- 10			
- 11			
- 12			
- 13			
- 14			
- 16			
- 17			
- 18			
- 19			
- 20			
-			
- 22			
- 24			
- 26			
- 28			
- 30			
- 32			
- 34			

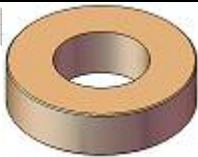

INJECTOR PIPE WASHER

رنديلة بخاخ

	السعر	العدد	ملاحظات
PART REF.	PRICE	QTY	REM.
I-P-W- 12			
- 14			
- 18			

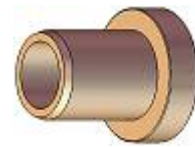

INJECTOR PIPE FILLING

حشوة بوري بخاخ

	السعر	العدد	ملاحظات
PART REF.	PRICE	QTY	REM.
I-P-F- 12			
- 14			

HYDRO – TEC

JIC BRAKE PIPE MALE NUT

عزقة فرام ذكر أمريكي

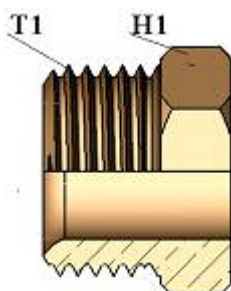

	السعر	العدد	شرار- سن	القياسات مم	ملاحظات
PART REF.	PRICE	QTY	THREAD	DIMENSIONS mm	REM.
			T	H1	
JIC-BM-N - 03			3/8" - 24	12	
- 04			7/16" - 20	14	
- 05			1/2" - 18	17	
- 07			5/8" - 18	17	
- 08			3/4" - 16	19	
- 10			7/8" - 14	22	

METRIC NUT FOR INJECTOR

عزقة بوري بخاخ متري

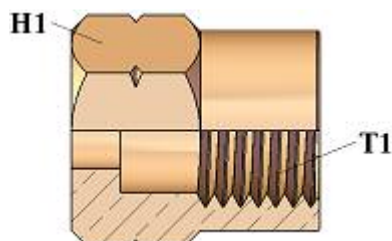

	السعر	العدد	شرار- سن	القياسات مم	ملاحظات
PART REF.	PRICE	QTY	THREAD	DIMENSIONS mm	REM.
			T1	H1	
M-I-N - 12			M12x1.5	14	
- 14			M14x1.5	17	
- 18			M18x1.5	22	
- 22			M22x1.5	27	
- 26			M26x1.5	32	

METRIC FLANGED BLANKING PLUG

سدة كارتيل متري



	السعر	العدد	شرار- سن	ملاحظات
PART REF.	PRICE	QTY	THREAD	REM.
			T	
M-F-P - 12			M12x1.5	
- 14			M14x1.5	
- 16			M16x1.5	
- 18			M18x1.5	
- 20			M20x1.5	
- 22			M22x1.5	
- 24			M24x1.5	
- 26			M26x1.5	
- 30			M30x1.5	

HYDRO – TEC

JIC BRAKE PIPE FEMALE NUT

عزقة طربوش أمريكي

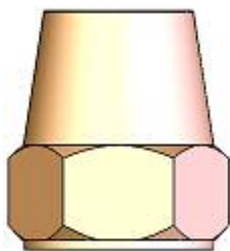

ملاحظات	القياسات مم	شرار - سن	العدد	السعر	
REM.	DIMENSIONS mm		QTY	PRICE	PART REF.
	PIPE	T			
	1/4"	7/16" - 20			JIC-B-N - 04
	5/16"	1/2" - 20			- 05
	3/8"	9/16" - 18			- 06
	3/8"	5/8" - 18			- 07
	1/2"	3/4" - 16			- 08
	5/8"	7/8" - 14			- 10



HT-SP SPRING FOR HOSE

نابض للخرطوم

ملاحظات	قطر الخرطوم الخارجي مم		قياس النابض	العدد	السعر	النوع
REM.	OUTSIDE HOSE DIAMETER		SPRING SIZE	QTY	PRICE	PART REF.
	MIN mm	MAX mm	ID mm			
	13	14	15			HT - SP- 03
	14.5	16	17			- 04
	16.5	18	19			- 05
	18.5	22	23			- 06
	22.5	25	26			- 08
	25.5	28	29			- 10
	28.5	33	34			- 12
	33.5	40	41			- 16
	40.5	47	48			- 20
	50.5	56	57			- 24
	63.5	69	70			- 32

HYDRO – TEC

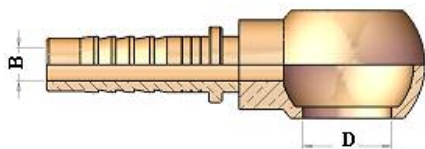

HT20310 BSP BANJO

بانجو لسن إنكليزي

PART REF.	السعر	العدد	فتحة الخرطوم		القياسات مم		ملاحظات
	PRICE	QTY	DN	INCH	B	D	REM.
HT20310 - 04 - 04			6	1/4"	4.1	13.3	
- 05 - 06			8	5/16"	7.1	16.7	
- 06 - 06			10	3/8"	7.1	16.7	
- 06 - 08			10	3/8"	7.1	21	
- 08 - 08			12	1/2"	9.6	21	
- 10 - 10			16	5/8"	12.1	23	
- 12 - 12			19	3/4"	15	26.5	
- 16 - 16			25	1"	20	33.3	

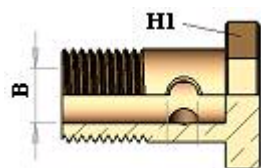

HT80210 BSP BOLT

برغي سن إنكليزي

PART REF.	السعر	العدد	شرار - سن	القياسات مم		ملاحظات
	PRICE	QTY	THREAD	B	H1	REM.
HT80210 - 04			1/4" - 19	7	17	
- 06			3/8" - 19	9	22	
- 08			1/2" - 14	13	27	
- 10			5/8" - 14	13.5	30	
- 12			3/4" - 14	17	32	
- 16			1" - 11	22	41	

HYDRO – TEC

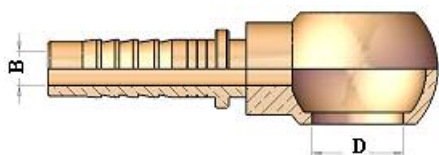

HT20910 METRIC BANJO DIN 7622

بانجو متري

PART REF.	السعر	العدد	فتحة الخرطوم		قطر البرغي	القياسات مم		ملاحظات
	PRICE	QTY	DN	INCH	METRIC BOLT	B	D	
HT20910 - 04 - 10			6	1/4"	M 10x1	4	10	
- 04 - 12			6	1/4"	M 12x1.5	4	12	
- 04 - 14			6	1/4"	M 14x1.5	4	14	
- 05 - 14			8	5/16"	M 14x1.5	5	14	
- 06 - 14			10	3/8"	M14x1.5	7	14	
- 06 - 16			10	3/8"	M 16x1.5	7	16	
- 06 - 18			10	3/8"	M 18x1.5	8	18	
- 08 - 18			12	1/2"	M 18x1.5	7	18	
- 08 - 22			12	1/2"	M 22x1.5	8	22	
- 10 - 22			16	5/8"	M 22x1.5	10	22	
- 12 - 26			19	3/4"	M 26x1.5	10	26	
- 16 - 30			25	1"	M 30x1.5	11	30	

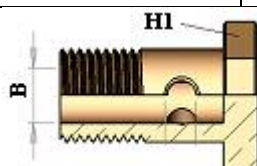

HT80810 METRIC BOLT

برغي متري قصير

PART REF.	السعر	العدد	ش.ر.ر. سن	القياسات مم		ملاحظات
	PRICE	QTY	THREAD	B	H1	
HT80810 - 06			M 12x0.75	4	10	
- 08			M 12x0.75	5	12	
- 08			M 12x1.5	5	12	
- 08			M 12x1.25	5	12	
- 10			M 10x1	6	14	
- 10			M 10x1.25	6	14	
- 10			M 10x1.5	6	14	
- 12			M 12x1.25	7	17	
- 12			M 12x1.5	7	17	
- 14			M 14x1.5	9	19	
- 16			M 16x1.5	11	22	
- 18			M 18x1.5	13	24	
- 22			M 22x1.5	16	27	
- 26			M 26x1.5	20	32	
- 30			M 30x1.5	24	41	

HYDRO – TEC



HT80810L LONG METRIC BOLT

برغي متري طويل

PART REF.	السعر	العدد	شرار - سن	القياسات مم		ملاحظات
	PRICE	QTY	THREAD	DIMENSIONS mm		
			T	B	H1	REM.
HT80810 - 12L			M 12x1.5	7	17	
- 14L			M 14x1.5	9	19	
- 16L			M 16x1.5	11	22	
- 18L			M 18x1.5	13	24	
- 22L			M 22x1.5	16	27	
- 26L			M 26x1.5	20	32	
- 30L			M 30x1.5	24	41	

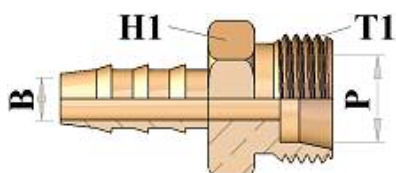

HT11410 METRIC AIR MALE

ذكر هواء متري

PART REF.	السعر	العدد	شرار - سن	قياس الخرطوم	القياسات مم		ملاحظات
	PRICE	QTY	THREAD	HOSE SIZE	DIMENSIONS mm		
			T	mm	B	H1	REM.
HT11410 - 06 - 12			M 12x1.5	6	3.1	14	
- 06 - 14			M 14x1.5	6	3.1	17	
- 08 - 14			M 14x1.5	8	5.5	17	
- 08 - 16			M 16x1.5	8	5.5	18	
- 10 - 14			M 14x1.5	10	7.5	19	
- 10 - 16			M 16x1.5	10	7.5	19	
- 10 - 18			M 18x1.5	10	7.5	22	
- 12 - 18			M 18x1.5	12	9.6	22	
- 12 - 22			M 22x1.5	12	9.6	24	
- 16 - 22			M 26x1.5	16	12.5	24	

HYDRO – TEC

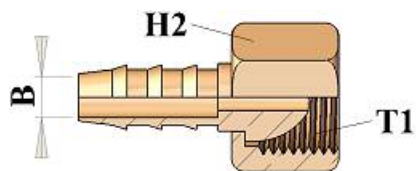

HT21413 METRIC AIR FEMALE

متحرك هواء ممتري

PART REF.	السعر	العدد	شراير - سن	قياس الخرطوم	القياسات مم		ملاحظات
	PRICE	QTY	THREAD	HOSE SIZE	DIMENSIONS mm		
			T1	mm	B	H2	REM.
HT21413 - 06 - 12			M 12x1.5	6	3.1	14	
- 06 - 14			M 14x1.5	6	3.1	17	
- 08 - 14			M 14x1.5	8	5.5	17	
- 08 - 16			M 16x1.5	8	5.5	18	
- 10 - 14			M 14x1.5	10	7.5	19	
- 10 - 16			M 16x1.5	10	7.5	19	
- 10 - 18			M 18x1.5	10	7.5	22	
- 12 - 18			M 18x1.5	12	9.6	22	
- 12 - 22			M 22x1.5	12	9.6	27	
- 16 - 22			M 26x1.5	16	12.5	27	

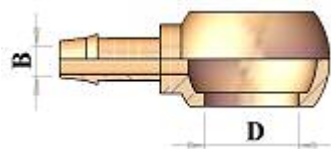

HT20410 AIR BANGO (ONE NOTCH)

بانجو هواء ذنب حز واحد

PART REF.	السعر	العدد	قياس الخرطوم	القياسات مم		ملاحظات
	PRICE	QTY	HOSE SIZE	DIMENSIONS mm		
			INCH	B	D	REM.
HT20410 - 06 - 06			6	3.1	6	
- 06 - 08			6	3.1	8	
- 08 - 08			8	5.5	8	
- 06 - 10			6	3.1	10	
- 08 - 10			8	5.5	10	
- 10 - 10			10	7.5	10	
- 06 - 12			6	3.1	12	
- 08 - 12			8	5.5	12	
- 10 - 12			10	7.5	12	
- 12 - 12			12	9.6	12	
- 06 - 14			6	3.1	14	
- 08 - 14			8	5.5	14	
- 10 - 14			10	7.5	14	
- 12 - 14			12	9.6	14	
- 06 - 16			6	3.1	16	
- 08 - 16			8	5.5	16	
- 10 - 16			10	7.5	16	
- 12 - 16			12	9.6	16	

HYDRO – TEC

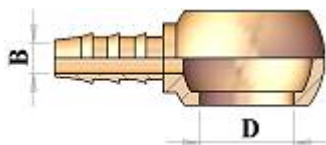

HT20430 AIR BANGO (THREE NOTCH)

بانجو هواء ذنب ثلاث حوز

PART REF.	السعر	العدد	قياس الخرطوم	القياسات مم		ملاحظات
	PRICE	QTY	HOSE SIZE INCH	B	D	REM.
HT20430 - 06 - 06			6	3.1	6	
- 06 - 08			6	3.1	8	
- 08 - 08			8	5.5	8	
- 06 - 10			6	3.1	10	
- 08 - 10			8	5.5	10	
- 10 - 10			10	7.5	10	
- 06 - 12			6	3.1	12	
- 08 - 12			8	5.5	12	
- 10 - 12			10	7.5	12	
- 12 - 12			12	9.6	12	
- 06 - 14			6	3.1	14	
- 08 - 14			8	5.5	14	
- 10 - 14			10	7.5	14	
- 12 - 14			12	9.6	14	
- 06 - 16			6	3.1	16	
- 08 - 16			8	5.5	16	
- 10 - 16			10	7.5	16	
- 12 - 16			12	9.6	16	

A /C CATALOGUE



A/C INDEX

PAGE	PART REF.	STANDARD TYPE	النوع
143	8001 - 8005	IRON JACKET	سوكيت حديد
144	2001 - 2015	ALUMINUN O-RING JOINT WITH IRON CAP	رأس ألمنيوم سيولة مع عزقة حديد
145	2016 - 2027	ALUMINUN FLARE JOINT WITH IRON CAP	رأس ألمنيوم كونيك مع عزقة حديد
146	2028 - 2039	QUICK FLARE JOINT	وصلة سريعة كونيك
147	2040 - 2051	QUICK O-RING JOINT	وصلة سريعة سيولة
148	2052 - 2063	ALUMINUM O-RING JOINT (IRON OUTER SCREW)	رأس ألمنيوم سيولة (شرار ذكر حديد)
149	2064 - 2075	ALUMINUM FLARE JOINT (IRON OUTER SCREW)	رأس ألمنيوم كونيك (شرار ذكر حديد)
150	2076 – 2090	ALUMINUM O-RING JOINT (ALUMINUM OUTER SCREW)	رأس ألمنيوم سيولة (شرار ذكر ألمنيوم)
151	2301 - 2315	ALUMINUN O-RING JOINT WITH R12 VALVE	رأس ألمنيوم سيولة مع بلف R12
152	2301A – 2315A	ALUMINUN O-RING JOINT WITH R12 VALVE HIGH & LOW PRESSURE	رأس ألمنيوم سيولة مع بلف R12 ضغط عالي ومنخفض
153	2316 - 2327	ALUMINUN FLARE JOINT WITH R12	رأس ألمنيوم كونيك مع بلف R12
154	2316A – 2327A	ALUMINUN FLARE JOINT WITH R12 VALVE HIGH & LOW PRESSURE	رأس ألمنيوم كونيك مع بلف R12 ضغط عالي ومنخفض
155	2316B – 2327B	ALUMINUN FLARE JOINT WITH R134a VALVE HIGH & LOW PRESSURE	رأس ألمنيوم كونيك مع بلف R134a ضغط عالي ومنخفض
156	3016 - 3024	FULL IRON FLARE JOINT	رأس كامل حديد كونيك
157	3101- 3115	IRON O-RING JOINT WITH IRON JACKET	رأس وسوكيت حديد سيولة
158	3116 - 3124	FULL IRON FLARE JOINT WITH IRON JACKET	رأس كامل حديد كونيك مع سوكيت حديد
158	3207- 3209	IRON O-RING JOINT WITH R12 VALVE	رأس حديد سيولة مع بلف R12
159	5001 – 5012	ENVIRONMENT-FRIENDLY ALUMINUM JOINT	رأس ألمنيوم أنثى شرار ملي متري
160	5051- 5062	ENVIRONMENT-FRIENDLY ALUMINUM JOINT	رأس ألمنيوم ذكر شرار ملي متري
161		IRON THROUGH PIPE	وصلة خرطوم حديد
162		TEE PIPE	مثلث ألمنيوم
163	3055 - 3058	ALUMINUM ELBOW JOINT	ذنب لحام ألمنيوم
163	9002	ALUMINUM VALVE SEAT	قاعدة بلف ألمنيوم



IRON JACKET

سوكيت حديد

PART REF.	DIN	INNER BORE	LENGTH	REAR BORE	SMALL BORE
HT8001	5/16"	19.5	35	9.6	3
HT8002	13/32"	23.5	35	12.3	3
HT8004	1/2"	26	35	14.3	3
HT8005	5/8"	29	35	18	3



ALUMINUM O-RING JOINT WITH IRON CAP

رأس الألمنيوم سيطة مع عزقة حديد

PART REF.	DEGREE	TYPE	TAIL	SCREW
HT2001	ST	Female O-Ring	5/16"	9/16-18UNF
HT2002	45°	Female O-Ring	5/16"	9/16-18UNF
HT2003	90°	Female O-Ring	5/16"	9/16-18UNF
HT2004	ST	Female O-Ring	5/16"	5/8-18UNF
HT2005	45°	Female O-Ring	5/16"	5/8-18UNF
HT2006	90°	Female O-Ring	5/16"	5/8-18UNF
HT2007	ST	Female O-Ring	13/32"	3/4-16UNF
HT2008	45°	Female O-Ring	13/32"	3/4-16UNF
HT2009	90°	Female O-Ring	13/32"	3/4-16UNF
HT2010	ST	Female O-Ring	1/2"	7/8-14UNF
HT2011	45°	Female O-Ring	1/2"	7/8-14UNF
HT2012	90°	Female O-Ring	1/2"	7/8-14UNF
HT2013	ST	Female O-Ring	5/8"	1.1/16-14UNS
HT2014	45°	Female O-Ring	5/8"	1.1/16-14UNS
HT2015	90°	Female O-Ring	5/8"	1.1/16-14UNS



ALUMINUM FLARE JOINT WITH IRON CAP

رأس الألمنيوم كونيك مع عزقة حديد

PART REF.	DEGREE	TYPE	TAIL	SCREW
HT2016	ST	Female Flare	5/16"	5/8-18UNF
HT2017	45°	Female Flare	5/16"	5/8-18UNF
HT2018	90°	Female Flare	5/16"	5/8-18UNF
HT2019	ST	Female Flare	13/32"	3/4-16UNF
HT2020	45°	Female Flare	13/32"	3/4-16UNF
HT2021	90°	Female Flare	13/32"	3/4-16UNF
HT2022	ST	Female Flare	1/2"	7/8-14UNF
HT2023	45°	Female Flare	1/2"	7/8-14UNF
HT2024	90°	Female Flare	1/2"	7/8-14UNF
HT2025	ST	Female Flare	5/8"	1.1/16-14UNS
HT2026	45°	Female Flare	5/8"	1.1/16-14UNS
HT2027	90°	Female Flare	5/8"	1.1/16-14UNS



QUICK JOINT Flare وصلة سريعة كونيك

PART REF.	DEGREE	TYPE	TAIL	SCREW
HT2028	ST	Flare	5/16"	
HT2029	45°	Flare	5/16"	
HT2030	90°	Flare	5/16"	
HT2031	ST	Flare	13/32"	
HT2032	45°	Flare	13/32"	
HT2033	90°	Flare	13/32"	
HT2034	ST	Flare	1/2"	
HT2035	45°	Flare	1/2"	
HT2036	90°	Flare	1/2"	
HT2037	ST	Flare	5/8"	
HT2038	45°	Flare	5/8"	
HT2039	90°	Flare	5/8"	



QUICK O-RING JOINT

وصلة سريعة سيالة

PART REF.	DEGREE	TYPE	TAIL	SCREW
HT2040	ST	O-Ring	5/16"	
HT2041	45°	O-Ring	5/16"	
HT2042	90°	O-Ring	5/16"	
HT2043	ST	O-Ring	13/32"	
HT2044	45°	O-Ring	13/32"	
HT2045	90°	O-Ring	13/32"	
HT2046	ST	O-Ring	1/2"	
HT2047	45°	O-Ring	1/2"	
HT2048	90°	O-Ring	1/2"	
HT2049	ST	O-Ring	5/8"	
HT2050	45°	O-Ring	5/8"	
HT2051	90°	O-Ring	5/8"	



ALUMINUM O-RING JOINT (IRON OUTER SCREW) رأس أألنلوم سلةة (شرار ذكر حءلء)

PART REF.	DEGREE	TYPE	TAIL	SCREW
HT2052	ST	Male O-Ring	5/16"	5/8-18UNF
HT2053	45°	Male O-Ring	5/16"	5/8-18UNF
HT2054	90°	Male O-Ring	5/16"	5/8-18UNF
HT2055	ST	Male O-Ring	13/32"	3/4-18UNS
HT2056	45°	Male O-Ring	13/32"	3/4-18UNS
HT2057	90°	Male O-Ring	13/32"	3/4-18UNS
HT2058	ST	Male O-Ring	1/2"	7/8-18UNS
HT2059	45°	Male O-Ring	1/2"	7/8-18UNS
HT2060	90°	Male O-Ring	1/2"	7/8-18UNS
HT2061	ST	Male O-Ring	5/8"	1.1/16-16UNS
HT2062	45°	Male O-Ring	5/8"	1.1/16-16UNS
HT2063	90°	Male O-Ring	5/8"	1.1/16-16UNS



ALUMINUM FLARE JOINT (IRON OUTER SCREW) رأس ألمنيوم كونيك (شرار ذكر حديد)

PART REF.	DEGREE	TYPE	TAIL	SCREW
HT2064	ST	Male Flare	5/16"	5/8-18UNF
HT2065	45°	Male Flare	5/16"	5/8-18UNF
HT2066	90°	Male Flare	5/16"	5/8-18UNF
HT2067	ST	Male Flare	13/32"	3/4-18UNS
HT2068	45°	Male Flare	13/32"	3/4-18UNS
HT2069	90°	Male Flare	13/32"	3/4-18UNS
HT2070	ST	Male Flare	1/2"	7/8-18UNS
HT2071	45°	Male Flare	1/2"	7/8-18UNS
HT2072	90°	Male Flare	1/2"	7/8-18UNS
HT2073	ST	Male Flare	5/8"	1.1/16-16UNS
HT2074	45°	Male Flare	5/8"	1.1/16-16UNS
HT2075	90°	Male Flare	5/8"	1.1/16-16UNS

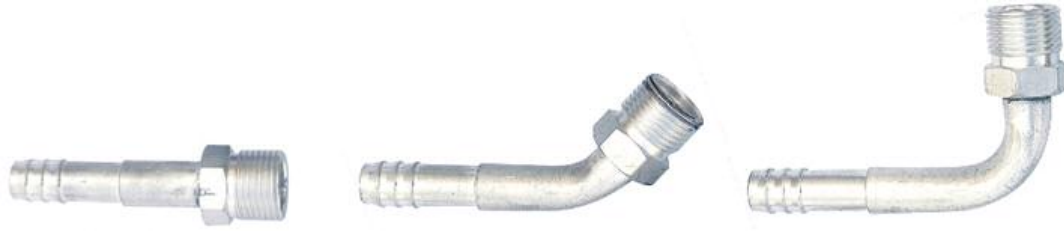

ALUMINUM O-RING JOINT (ALUMINUM OUTER SCREW) رأس ألمنيوم سيطة (شرار ذكر ألمنيوم)

PART REF.	DEGREE	TYPE	TAIL	SCREW
HT2076	ST	Male O-Ring	5/16"	9/16-18UNF
HT2077	45°	Male O-Ring	5/16"	9/16-18UNF
HT2078	90°	Male O-Ring	5/16"	9/16-18UNF
HT2079	ST	Male O-Ring	5/16"	5/8-18UNF
HT2080	45°	Male O-Ring	5/16"	5/8-18UNF
HT2081	90°	Male O-Ring	5/16"	5/8-18UNF
HT2082	ST	Male O-Ring	13/32"	3/4-16UNF
HT2083	45°	Male O-Ring	13/32"	3/4-16UNF
HT2084	90°	Male O-Ring	13/32"	3/4-16UNF
HT2085	ST	Male O-Ring	1/2"	7/8-14UNF
HT2086	45°	Male O-Ring	1/2"	7/8-14UNF
HT2087	90°	Male O-Ring	1/2"	7/8-14UNF
HT2088	ST	Male O-Ring	5/8"	1.1/16-14UNS
HT2089	45°	Male O-Ring	5/8"	1.1/16-14UNS
HT2090	90°	Male O-Ring	5/8"	1.1/16-14UNS



ALUMINUM O-RING JOINT WITH R12 VALVE
رأس ألومنيوم سيالة مع بلف R12

PART REF.	DEGREE	TYPE	TAIL	SCREW
HT2301	ST	Female O-Ring	5/16"	9/16-18UNF
HT2302	45°	Female O-Ring	5/16"	9/16-18UNF
HT2303	90°	Female O-Ring	5/16"	9/16-18UNF
HT2304	ST	Female O-Ring	5/16"	5/8-18UNF
HT2305	45°	Female O-Ring	5/16"	5/8-18UNF
HT2306	90°	Female O-Ring	5/16"	5/8-18UNF
HT2307	ST	Female O-Ring	13/32"	3/4-16UNF
HT2308	45°	Female O-Ring	13/32"	3/4-16UNF
HT2309	90°	Female O-Ring	13/32"	3/4-16UNF
HT2310	ST	Female O-Ring	1/2"	7/8-14UNF
HT2311	45°	Female O-Ring	1/2"	7/8-14UNF
HT2312	90°	Female O-Ring	1/2"	7/8-14UNF
HT2313	ST	Female O-Ring	5/8"	1.1/16-14UNS
HT2314	45°	Female O-Ring	5/8"	1.1/16-14UNS
HT2315	90°	Female O-Ring	5/8"	1.1/16-14UNS



ALUMINUM O-RING JOINT WITH R12 VALVE HIGH & LOW PRESSURE

رأس الألمنيوم سيطة مع بلف R12 ضغط عالي ومنخفض

PART REF.	DEGREE	TYPE	TAIL	SCREW
HT2301-A	ST	Female O-Ring	5/16"	9/16-18UNF
HT2302-A	45°	Female O-Ring	5/16"	9/16-18UNF
HT2303-A	90°	Female O-Ring	5/16"	9/16-18UNF
HT2304-A	ST	Female O-Ring	5/16"	5/8-18UNF
HT2305-A	45°	Female O-Ring	5/16"	5/8-18UNF
HT2306-A	90°	Female O-Ring	5/16"	5/8-18UNF
HT2307-A	ST	Female O-Ring	13/32"	3/4-16UNF
HT2308-A	45°	Female O-Ring	13/32"	3/4-16UNF
HT2309-A	90°	Female O-Ring	13/32"	3/4-16UNF
HT2310-A	ST	Female O-Ring	1/2"	7/8-14UNF
HT2311-A	45°	Female O-Ring	1/2"	7/8-14UNF
HT2312-A	90°	Female O-Ring	1/2"	7/8-14UNF
HT2313-A	ST	Female O-Ring	5/8"	1.1/16-14UNS
HT2314-A	45°	Female O-Ring	5/8"	1.1/16-14UNS
HT2315-A	90°	Female O-Ring	5/8"	1.1/16-14UNS



ALUMINUM FLARE JOINT WITH R12 رأس ألومنيوم كونيك مع بلف R12

PART REF.	DEGREE	TYPE	TAIL	SCREW
HT2316	ST	Female Flare	5/16"	5/8-18UNF
HT2317	45°	Female Flare	5/16"	5/8-18UNF
HT2318	90°	Female Flare	5/16"	5/8-18UNF
HT2319	ST	Female Flare	13/32"	3/4-16UNF
HT2320	45°	Female Flare	13/32"	3/4-16UNF
HT2321	90°	Female Flare	13/32"	3/4-16UNF
HT2322	ST	Female Flare	1/2"	7/8-14UNF
HT2323	45°	Female Flare	1/2"	7/8-14UNF
HT2324	90°	Female Flare	1/2"	7/8-14UNF
HT2325	ST	Female Flare	5/8"	1.1/16-14UNS
HT2326	45°	Female Flare	5/8"	1.1/16-14UNS
HT2327	90°	Female Flare	5/8"	1.1/16-14UNS



ALUMINUM FLARE JOINT WITH R12 VALVE HIGH & LOW PRESSURE

رأس الألمنيوم كونيكت مع بلف R12 ضغط عالي ومنخفض

PART REF.	DEGREE	TYPE	TAIL	SCREW
HT2316-A	ST	Female Flare	5/16"	5/8-18UNF
HT2317-A	45°	Female Flare	5/16"	5/8-18UNF
HT2318-A	90°	Female Flare	5/16"	5/8-18UNF
HT2319-A	ST	Female Flare	13/32"	3/4-16UNF
HT2320-A	45°	Female Flare	13/32"	3/4-16UNF
HT2321-A	90°	Female Flare	13/32"	3/4-16UNF
HT2322-A	ST	Female Flare	1/2"	7/8-14UNF
HT2323-A	45°	Female Flare	1/2"	7/8-14UNF
HT2324-A	90°	Female Flare	1/2"	7/8-14UNF
HT2325-A	ST	Female Flare	5/8"	1.1/16-14UNS
HT2326-A	45°	Female Flare	5/8"	1.1/16-14UNS
HT2327-A	90°	Female Flare	5/8"	1.1/16-14UNS



ALUMINUM FLARE JOINT WITH R134a VALVE HIGH & LOW PRESSURE

رأس ألمنيوم كونيك مع بلف R134a ضغط عالي ومنخفض

PART REF.	DEGREE	TYPE	TAIL	SCREW
HT2316-B	ST	Female Flare	5/16"	5/8-18UNF
HT2317-B	45°	Female Flare	5/16"	5/8-18UNF
HT2318-B	90°	Female Flare	5/16"	5/8-18UNF
HT2319-B	ST	Female Flare	13/32"	3/4-16UNF
HT2320-B	45°	Female Flare	13/32"	3/4-16UNF
HT2321-B	90°	Female Flare	13/32"	3/4-16UNF
HT2322-B	ST	Female Flare	1/2"	7/8-14UNF
HT2323-B	45°	Female Flare	1/2"	7/8-14UNF
HT2324-B	90°	Female Flare	1/2"	7/8-14UNF
HT2325-B	ST	Female Flare	5/8"	1.1/16-14UNS
HT2326-B	45°	Female Flare	5/8"	1.1/16-14UNS
HT2327-B	90°	Female Flare	5/8"	1.1/16-14UNS



FULL IRON FLARE JOINT

رأس كامل حديد كونيك

PART REF.	DEGREE	TYPE	TAIL	SCREW
HT3016	ST	Female Flare	5/16"	5/8-18UNF
HT3017	45°	Female Flare	5/16"	5/8-18UNF
HT3018	90°	Female Flare	5/16"	5/8-18UNF
HT3019	ST	Female Flare	13/32"	3/4-16UNF
HT3020	45°	Female Flare	13/32"	3/4-16UNF
HT3021	90°	Female Flare	13/32"	3/4-16UNF
HT3022	ST	Female Flare	1/2"	7/8-14UNF
HT3023	45°	Female Flare	1/2"	7/8-14UNF
HT3024	90°	Female Flare	1/2"	7/8-14UNF



IRON O-RING JOINT WITH IRON JACKET

رأس وسوكيت حديد سيلة

PART REF.	DEGREE	TYPE	TAIL	SCREW
HT3101	ST	Female O-Ring	5/16"	9/16-18UNF
HT3102	45°	Female O-Ring	5/16"	9/16-18UNF
HT3103	90°	Female O-Ring	5/16"	9/16-18UNF
HT3104	ST	Female O-Ring	5/16"	5/8-18UNF
HT3105	45°	Female O-Ring	5/16"	5/8-18UNF
HT3106	90°	Female O-Ring	5/16"	5/8-18UNF
HT3107	ST	Female O-Ring	13/32"	3/4-16UNF
HT3108	45°	Female O-Ring	13/32"	3/4-16UNF
HT3109	90°	Female O-Ring	13/32"	3/4-16UNF
HT3110	ST	Female O-Ring	1/2"	7/8-14UNF
HT3111	45°	Female O-Ring	1/2"	7/8-14UNF
HT3112	90°	Female O-Ring	1/2"	7/8-14UNF
HT3113	ST	Female O-Ring	5/8"	1.1/16-14UNS
HT3114	45°	Female O-Ring	5/8"	1.1/16-14UNS
HT3115	90°	Female O-Ring	5/8"	1.1/16-14UNS



FULL IRON FLARE JOINT WITH IRON JACKET

رأس كامل حديد كونيك مع سوكيت حديد

PART REF.	DEGREE	TYPE	TAIL	SCREW
HT3116	ST	Female Flare	5/16"	5/8-18UNF
HT3117	45°	Female Flare	5/16"	5/8-18UNF
HT3118	90°	Female Flare	5/16"	5/8-18UNF
HT3119	ST	Female Flare	13/32"	3/4-16UNF
HT3120	45°	Female Flare	13/32"	3/4-16UNF
HT3121	90°	Female Flare	13/32"	3/4-16UNF
HT3122	ST	Female Flare	1/2"	7/8-14UNF
HT3123	45°	Female Flare	1/2"	7/8-14UNF
HT3124	90°	Female Flare	1/2"	7/8-14UNF



IRON O-RING JOINT WITH R12 VALVE

رأس حديد سيطة مع بلف R12

PART REF.	DEGREE	TYPE	TAIL	SCREW
HT3207	ST	Female O-Ring	13/32"	3/4-16UNF
HT3209	90°	Female O-Ring	13/32"	3/4-16UNF



ENVIRONMENT-FRIENDLY ALUMINUM JOINT

رأس الألمنيوم أنثى شرار ملي متري

PART REF.	DEGREE	TYPE	TAIL	SCREW
HT5001	ST	Female	5/16"	M16x1.5
HT5002	45°	Female	5/16"	M16x1.5
HT5003	90°	Female	5/16"	M16x1.5
HT5004	ST	Female	13/32"	M22x1.5
HT5005	45°	Female	13/32"	M22x1.5
HT5006	90°	Female	13/32"	M22x1.5
HT5007	ST	Female	1/2"	M24x1.5
HT5008	45°	Female	1/2"	M24x1.5
HT5009	90°	Female	1/2"	M24x1.5
HT5010	ST	Female	5/8"	M27x1.5
HT5011	45°	Female	5/8"	M27x1.5
HT5012	90°	Female	5/8"	M27x1.5



ENVIRONMENT-FRIENDLY ALUMINUM JOINT

رأس ألومنيوم ذكر شرار ملي متري

PART REF.	DEGREE	TYPE	TAIL	SCREW
HT5051	ST	Male	5/16"	M16x1.5
HT5052	45°	Male	5/16"	M16x1.5
HT5053	90°	Male	5/16"	M16x1.5
HT5054	ST	Male	13/32"	M22x1.5
HT5055	45°	Male	13/32"	M22x1.5
HT5056	90°	Male	13/32"	M22x1.5
HT5057	ST	Male	1/2"	M24x1.5
HT5058	45°	Male	1/2"	M24x1.5
HT5059	90°	Male	1/2"	M24x1.5
HT5060	ST	Male	5/8"	M27x1.5
HT5061	45°	Male	5/8"	M27x1.5
HT5062	90°	Male	5/8"	M27x1.5



IRON THROUGH PIPE

وصلة خرطوم حديد

PART REF.	HT3051	HT3052	HT3053
TAIL	5/16	13/32	1/2



IRON THROUGH PIPE WITH IRON JACKET

وصلة خرطوم حديد مع سوكت حديد

PART REF.	HT3151	HT3152	HT3153
TAIL	5/16	13/32	1/2



IRON THROUGH PIPE WITH IRON JACKET R134a HIGH & LOW PRESSURE VALVE

وصلة خرطوم حديد مع سوكت حديد و بلف R134a ضغط عالي ومنخفض

PART REF.	HT3351-B
TAIL	5/16



ALUMINUM THROUGH PIPE

وصلة خرطوم ألومنيوم

PART REF.	HT6001	HT6002	HT6003	HT6004
TAIL	5/16	13/32	1/2	5/8



TEE PIPE
مثالث أألنيوم

PART REF.	HT6101	HT6102	HT6103	HT6104
TAIL	5/16	13/32	1/2	5/8



ALUMINUM THROUGH PIPE WITH R12 VALVE
وصلة خرطوم أألنيوم مع بلف R12

PART REF.	HT6201	HT6202	HT6203	HT6204
TAIL	5/16	13/32	1/2	5/8



ALUMINUM THROUGH PIPE WITH R134a VALVE HIGH & LOW PRESSURE VALVE
وصلة خرطوم أألنيوم مع بلف R134a ضغط عالي ومنخفض

PART REF.	HT6201-B	HT6202-B	HT6203-B	HT6204-B
TAIL	5/16	13/32	1/2	5/8



ALUMINUM ELBOW JOINT

ذنب لحام ألومنيوم

PART REF.	HT3055	HT3056	HT3057	HT3058
TAIL	5/16	13/32	1/2	5/8



ALUMINUM VALVE SEAT

قاعدة بلف ألومنيوم

PART REF.	USE FOR	SCREW
HT9002	R12	7/16-20UNF



HYDRO-TEC

بعون الله بنيناها

HYDRO-TEC

أسميناها

ولأننا عن آباءنا وأجدادنا ورثناها

طورناها وحدثناها

معتمدين على توفيق الله أولاً ومن ثم على الخبرات التي وظفناها في سبيل تحقيق ما نرثنا إليه من أهداف.

تأسست الشركة عام ١٩٩٥ وكان اختصاصها إنتاج رؤوس خراطيم الهيدروليك المصنعة من المعادن الألمانية فسعيننا منذ البداية أن نهتم بالدقة والنوعية ولو كان ذلك على حساب الكمية لأن الجودة هدفنا.

ومن منطلق (أننا لسنا الوحيدين ولسنا الأفضل ولكننا نسعى لأن نكون كذلك):

- واكبنا أحدث التطورات في العالم فاستوردنا المخارط المبرمجة الحديثة CNC التي تحقق الدقة والسرعة في آن واحد.
- اعتمدنا على مهندسين مختصين في مجال الرسم الصناعي وتشغيل وصيانة الآلات الحديثة.
- انتقينا يداً عاملة خبيرة في مجال عملنا.

لنكون أسرة متكاملة تعمل كيداً واحدة تمتد لتصافح أيديكم

سعيننا بداية لتلبية حاجات السوق المحلية ثم ارتقينا إلى فضاء السوق العربية وما بعدها، وكان لنا شرف الريادة من حيث الجودة والدقة والتعددية في الأصناف معتمدين القياسات العالمية، كما أنه لدينا القدرة على صناعة القطع المميزة (من حيث الشكل أو القياس) التي لا يمكن إنتاجها على المخارط العادية.

و لأن رضائكم هو غايتنا

- قمنا بدراسة الأسعار دراسة منهجية بحيث تناسب البائع وترضي الزبون.
- حافظنا على جودة القطع بتغليفها (بلاستيك + شبك) وتعليبها في صناديق متينة ذات شكل لائق.
- تعاقدنا مع أفضل شركات الشحن من حيث السرعة والدقة في المواعيد والاهتمام بالبضائع.
- تقبلنا ونتقبل نصحكم بوسع الصدر لأنه منبع تطورنا وتقديمنا فلا تبخلوا به علينا.



HYDRO – TEC

FACTORY ADDRESS

MANAGER: ABDUL KADER BENSHI

MOBIL: 00963 - 933 - 450753

**TEL: 00963 - 21 - 4710551 / 2
00963 - 21 - 47288080**

FAX: 00963 - 21 - 47288088

E-MAIL: hydro-tec@benshigroup.com

ADDRESS: SYRIA - ALEPPO - P.O. 8307

INDUSTRIAL CITY (AL-SHEIKH NAJJAR)